



— 2004 Official Rule Book —

## NOTICE:

Each section of the Rule Book, except for the Association By-Laws and the AjPHA By-Laws, has been given the following prefix codes:

General Rules	= GR	Youth Program	= YP
Registration	= RG	Racing	= RA
Show and Contest	= SC	PAC Program	= PR
Amateur Program	= AM	Judges	= JU

New rules and changes to rules have been italicized and the type is in a blue screen. Page numbers are listed in the Table of Contents. Changes to rules permitted by the Rules or Executive Committee as significant clarifications are also italicized and printed in blue ink.

### EXAMPLE: New Rule in 2004.

E. **OBSTACLE REQUIREMENTS.** Course will include a minimum of 6 and a maximum of 10 obstacles and must be designed using *at least one* obstacle from each of the following divisions.

### EXAMPLE: Clarification.

- a. *One photograph, taken as close to the potential qualifying area as possible, but to include the entire potential qualifying area.*

**A Rule Book will be automatically mailed to new members or mailed upon the member's request. A new member is someone who has not ever had a membership or has not been a member in the previous twelve months. Additional copies are available for \$1 each.**

**For current updated information on the Paint Horse breed ... shows, sales, racing and articles of interest to Paint Horse enthusiasts, subscribe to the *Paint Horse Journal*, published monthly throughout the year. (One year subscription/member rate is \$30 and non-member is \$35.) (Canadian subscribers member rate is \$45 and non-member is \$50, International subscribers member rate is \$75 and non-member is \$80.)**

## FOR ADDITIONAL INFORMATION

### WRITE TO THE

### AMERICAN PAINT HORSE ASSOCIATION

#### Mailing Address:

**P.O. BOX 961023, FORT WORTH, TEXAS 76161-0023**

**Telephone: 817/834-APHA (2742) Fax: 817/834-3152**

#### Physical Address:

**2800 MEACHAM BLVD., FORT WORTH,**

**TEXAS 76137-4603**

**Visit us at: [www.apha.com](http://www.apha.com)**

**© 2004 by American Paint Horse Association**

## FOREIGN FEES

All foreign fees submitted to the Association must be in U.S. Funds.

**Canadian – Fees submitted by check or money order in U.S. funds only. Master Card or Visa is accepted with the following information: type of card, card holder, card number and expiration date. Bank wiring is also available (\$15 fee): please call or fax for wiring instructions. Phone (817) 834-2742 ext. 772; fax (817) 834-3152.**

**International –Master Card or Visa is accepted with the following information: type of card, card holder, card number and expiration date. Bank wiring is also available (\$15 fee): please call or fax for wiring instructions. Phone (817) 834-2742 ext. 772; fax (817) 834-3152.**

**Incoming Bank Wire Fee \$7.00 Domestic \$15.00 Foreign  
Return Check Fee \$25 Domestic Bank \$50 Foreign Bank  
Check Processing Policy: In the event that your check is returned unpaid for insufficient or uncollected funds, we may present your check electronically.**

## 2004 FEE SCHEDULE

All fees based on postmark - U. S. Funds Only  
(postal meters not accepted)

Fee	Members	Non-Members
<b>MEMBERSHIP / SUBSCRIPTION FEES</b>		
Annual Membership	\$25.00	\$25.00
3-Year Membership	\$65.00	\$65.00
5-Year Membership	\$100.00	\$100.00
AjPHA Membership	\$12.50	\$12.50
J-Term Membership	\$100.00	\$100.00
Lifetime	\$300.00	\$300.00
Lifetime Replacement Card Fee	\$5.00	\$5.00
PHJ Single Copy	\$4.50*	\$4.50*
US PHJ Subscription (1 Year)	\$30.00	\$35.00
US PHJ Subscription (3 Year)	\$75.00	\$90.00
Canadian PHJ Subscription (1 Year)	\$45.00	\$50.00
<i>Canadian PHJ Subscription (3 Year)</i>	<i>\$120.00</i>	<i>\$135.00</i>
International PHJ Subscription (1 Year)	\$75.00	\$80.00
*Add \$2 shipping & handling in U.S., outside U.S. add \$5		

## REGISTRATION FEES

<b>Regular Registry</b>		
<b>0-90 Days after Foaling or June 30 of the calendar year foaled, whichever is later</b>	\$20.00	\$45.00
<b>July 1 through September 30 of the calendar year foaled</b>	\$25.00	\$50.00
<b>October 1 through December 31 of the calendar year foaled</b>	\$35.00	\$70.00
<b>Yearling Year</b>	\$75.00	\$150.00
<b>2-Year-Old Year</b>	\$250.00	\$500.00
<b>3-Year-Old Year &amp; Older</b>	\$500.00	\$1000.00

<b>Fee</b>	<b>Members</b>	<b>Non-Members</b>
<b>Breeding Stock or Identification Status</b>		
<b>Jan.1-Dec. 31 Calendar Year Foaled</b>		
	<b>\$15.00</b>	<b>\$40.00</b>
<b>Yearling &amp; 2-Year-Old Year</b>	<b>\$50.00</b>	<b>\$100.00</b>
<b>3-Year-Old Year &amp; Older</b>	<b>\$100.00</b>	<b>\$200.00</b>
<b>Foreign Appendix Recording Fee</b>	<b>\$50.00</b>	<b>\$100.00</b>
<b>Foreign Appendix Ownership</b>		
<b>Update Fee</b>	<b>\$10.00</b>	<b>\$20.00</b>
<b>Re-Registrations</b>	<b>\$50.00</b>	<b>\$100.00</b>
<b>Status Changes*</b>	<b>\$20.00</b>	<b>\$45.00</b>
<b>*(plus difference in fee at time of registration)</b>		
<b>Transfer Fee</b>	<b>\$15.00</b>	<b>\$ 40.00</b>
<b>Stableman's Lien Fee</b>	<b>\$50.00</b>	<b>\$100.00</b>
<b>Transfer by Indemnity Fee</b>	<b>\$75.00</b>	<b>\$150.00</b>
<b>Transfer Date Correction</b>	<b>\$ 2.50</b>	<b>\$5.00</b>
<b>Rush Fee (per transaction)</b>		
<b>Registrations</b>	<b>\$50.00</b>	<b>\$100.00</b>
<b>Transfers</b>	<b>\$25.00</b>	<b>\$50.00</b>
<b>Misc. (duplicate certs., color changes, status changes, etc.)</b>	<b>\$25.00</b>	<b>\$50.00</b>
<b>See Rule RG-050.D. for other requirements on rush work.</b>		
<b>Fax Fee</b>		
<b>First Page</b>	<b>\$5.00</b>	<b>\$10.00</b>
<b>Each Additional Page</b>	<b>\$1.00</b>	<b>\$2.00</b>
<b>Inspection Fee*</b>	<b>\$100.00</b>	<b>\$200.00</b>
<b>*(film and processing charges will no longer be applicable)</b>		
<b>Inspection Fee (Special/Deposit)*</b>	<b>\$200.00</b>	<b>\$400.00</b>
<b>*(for possible fraudulent markings when skin biopsies and hair samples are required)</b>		
<b>Computer Flagging Fee</b>	<b>\$75.00</b>	<b>\$100.00</b>
<b>Corrected Certificate</b>	<b>\$20.00</b>	<b>\$45.00</b>
<b>Duplicate Certificate</b>	<b>\$20.00</b>	<b>\$45.00</b>
<b>Horse Name Change</b>	<b>\$100.00</b>	<b>\$200.00</b>
<b>Picture Replacement Certificate</b>	<b>\$20.00</b>	<b>\$45.00</b>
<b>Lease</b>	<b>\$12.50</b>	<b>\$37.50</b>
<b>Letters of Authorization</b>	<b>\$15.00</b>	<b>\$30.00</b>
<b>Mare Enrollment (Quarter/TB)</b>	<b>\$10.00</b>	<b>\$10.00</b>
<b>(First time producer of Paint foal)</b>		
<b>Office Processing Fee</b>	<b>\$10.00</b>	<b>\$10.00</b>
<b>Pedigrees</b>	<b>\$10.00</b>	<b>\$20.00</b>
<b>Signature Authorizations</b>	<b>\$ 5.00</b>	<b>\$30.00</b>

#### **STALLION BREEDING REPORT FEES (SBR)**

<b>Stallion Listing Fee</b>		
<b>(APHA, AQHA or TB)</b>	<b>\$75.00</b>	<b>\$150.00</b>
<b>SBR Filing Fees</b>	<b>\$10.00 plus</b>	<b>\$20.00 plus</b>
	<b>\$4.00 per mare</b>	<b>\$8.00 per mare</b>
<b>SBR Late Fee</b>	<b>\$25.00</b>	<b>\$50.00</b>
<b>Corrected SBR (per mare)</b>	<b>\$10.00</b>	<b>\$20.00</b>

Fee	Members	Non-Members
<b>FIELD SERVICES FEES</b>		
DNA Genetic Testing (per horse)	\$60.00	\$60.00
DNA Replacement Kit Fee	\$5.00	\$10.00
Embryo Transfer Fee	\$100.00	\$200.00
Embryo Transfer Late Fee*	\$200.00	\$400.00
*(mares enrolled after implant date)		
Embryo Transfer foals whose registrations are submitted after the 90-day limitation	\$100.00	\$200.00
Embryo Transfer Fee for mare and foal being late	\$300.00	\$600.00
Multiple Parentage Analysis	\$250.00	\$500.00
Cooled/Frozen Semen Permit Fee	\$100.00	\$200.00
Field Services Transaction Rush Fee	\$50.00	\$100.00
Cooled/Frozen Semen Permit Late Fee*	\$200.00	\$400.00
*(permit requested in less than 30 days after shipping)		
Pedigree Certification	1-4 horses \$60 per DNA Kit 5-9 horses \$55 per DNA Kit 10-14 horses \$50 per DNA Kit 15 or more horses \$45 per DNA Kit	
Tattoo Fee	\$55.00	N/A
<b>PERFORMANCE FEES</b>		
Amateur Card Application	\$15.00	\$30.00
Name Change Fee on Amateur Card	\$5.00	\$10.00
Amateur Replacement Card Fee	\$5.00	\$10.00
Amateur Application/Card Fax Fee	\$5.00	\$10.00
Rush Fee	\$25.00	\$50.00
Special Handling Fee (for amateur cards requested in less than 72 hours)	\$50.00	\$100.00
Temporary Amateur Cards (applied for at APHA-approved show rather than APHA office will automatically incur a \$25 rush fee).		
Amateur Card (including rush)	\$40.00	\$65.00
*Exception: Zone 12,13,14	\$15.00	\$30.00
Temporary Replacement Card	\$30.00	\$55.00
Show Application*	\$25.00	\$50.00
*Exception: Regional Clubs	\$25.00	N/A
Late Show Application Fee (plus \$25 show application fee)		
Less than 90 days	\$75.00	\$150.00
Less than 60 days	\$150.00	\$300.00
Show Results Processing Fee		
Single-Judge/2-Judge Specialty	\$2.00	\$2.00
Paint-O-Rama/Zone-O-Rama**	\$3.00	\$3.00
**Per horse per show (Judge)		
<i>Trail Ride Application Fee</i>	<i>\$25.00</i>	<i>N/A</i>
<i>    Plus Fee per Horse</i>	<i>\$2.00</i>	<i>N/A</i>
Judge's Filing Fee	\$50.00	\$50.00
Show/Race Records	\$5.00 (current)	\$10.00
Show /Race Records	\$10.00 (lifetime)	\$20.00

Fee	Members	Non-Members
<b>Get/Produce Records</b>	<b>\$ 5.00</b>	<b>\$10.00</b>
<b>Get/Produce Records with Points</b> <b>(Master Progeny)</b>	<b>\$10.00</b>	<b>\$20.00</b>
<b>PAC Enrollment</b>	<b>\$25.00</b>	<b>\$60.00</b>
<b>Ride America Enrollment</b>	<b>\$25.00 (must be APHA member)</b>	
<i>Novice Youth Card Application</i>	<i>\$15.00</i>	<i>\$30.00</i>
<i>Name Change on Novice Youth Card</i>	<i>\$5.00</i>	<i>\$10.00</i>
<i>Novice Youth Replacement Card Fee</i>	<i>\$5.00</i>	<i>\$10.00</i>
<i>Novice Youth Application/ Card Fax Fee</i>	<i>\$5.00</i>	<i>\$10.00</i>
<i>Novice Youth Card</i>		
<b>Rush Fee</b>	<b>\$25.00</b>	<b>\$50.00</b>
<b>Special Handling Fee</b> <i>(for novice youth cards requested in less than 72 hours)</i>	<b>\$50.00</b>	<b>\$100.00</b>
<b>Novice Youth Card</b> <i>(including rush)</i>	<b>\$40.00</b>	<b>\$65.00</b>

**ALL FEES SUBJECT TO CHANGE WITH OR WITHOUT NOTICE.**

**MEMBERSHIP FEES MAY BE PAID AT SAME TIME AS FEES FOR SERVICES ARE SUBMITTED.**

### **RACING CHART BOOKS**

Soft cover, lists horses and races by year, describes race and conditions, placings, speed index of each horse, each race. Cost of \$20.00 for each book includes postage. Check Choice.

___ 1966-74	___ 1981	___ 1985	___ 1989	___ 1993
___ 1975-76	___ 1982	___ 1986	___ 1990	___ 1994
___ 1977-78	___ 1983	___ 1987	___ 1991	___ 1995
___ 1979-80	___ 1984	___ 1988	___ 1992	___ 1996
___ 1997	___ 1998	___ 1999	___ 2000	___ 2001
___ 2002	___ 2003			

Complete set for \$540\_\_\_

## 2004 DEADLINES AND TENTATIVE MEETING SCHEDULE

**Refer to the *Paint Horse Journal* for other important dates throughout the year.**

### **January 1**

All horses are considered 1 year older on this date.

Regional Club Officers for current year must be submitted to the APHA office.

APHA office closed. (New Year's Day)

### **January 12**

Allocations and recommendation forms for Directors mailed to Regional Clubs.

### **January 15**

Postmark deadline for submission of rule change proposals to APHA office. (Receipt in APHA office by Jan. 20 regardless of postmark.)

### **February 2**

Postmark deadline for submission of membership to receive APHA Director Election ballot.

### **February 16**

Postmark deadline for submission of director recommendations from Regional Clubs and individual recommendations.

### **February 24**

Director recommendations must be received by APHA.

### **February 27-29**

Educational Judges Academy, Tampa, Florida.

### **March 1**

President announces the Nominating Committee for Directors.

### **March 24**

Director ballots mailed on or before this date to all regular and life members as of February 2, 2004.

### **April 9**

APHA office closed. (Good Friday)

### **April 22**

Intercollegiate Spring Sweepstakes Horse Judging Contest, Fort Worth, Texas.

Postmark deadline for return of members' ballots to CPA.

### **May 3**

President announces the Nominating Committee for Officers and Executive Committee.

Deadline for receipt of members' ballots, regardless of postmark.

### **May 31**

APHA office closed. (Memorial Day)

### **June 1**

Announcement of newly elected Directors.

### **June 3-5**

Annual Board of Directors Workshop, Harvey Hotel, Irving, Texas.

### **June 20-July 3**

AjPHA and APHA World Shows, Fort Worth, Texas.

### **June 25**

AjPHA Judging Contest.

### **June 30**

First Weanling Registration Deadline.

**July 5**

APHA office closed. (Independence Day)

**September 6**

APHA office closed. (Labor Day)

**September 30**

Second Weanling Registration Deadline.

**September 30-October 2**

2004 Gen. Membership Meeting and Annual Convention, Tucson, Arizona.

**November 25-26**

APHA office closed. (Thanksgiving)

**November 30**

Stallion Breeding Reports must be postmarked on or before this date.

Breeders Trust Sire Subscription (for 2005 breeding season).

**December 10-12**

Educational Judges Academy, Fort Worth, Texas.

**December 23-24**

APHA office closed. (Christmas)

**December 31**

Third Weanling Registration Deadline. (Yearling fee is higher.)

Breeders Trust Sire Subscription (for 2004 breeding season).

Breeders Trust Foal Nomination (2003 foals only).

APHA office closed. (New Year's Day)

**\*\*See Fee Schedule for graduated weanling registration deadlines.**

**2004 AjPHA TENTATIVE ACTIVITY CALENDAR****January 1**

AjPHA Regional Club Officer and Membership List due to APHA.  
2004 National Director Election Nominations due from Regional Clubs (postmark).

**February 1**

2004 National Director Election Ballots mailed to all AjPHA members by February 1.

**February 20-22**

American Youth Horse Council National Leaders Symposium, Irving, Texas.

**March 1**

\*YDF Scholarship Applications due.

2004 Director Nominations due (postmark).

2004 Club of the Year Scrapbooks due (postmark).

**March 31**

2004 National Directors informed by March 31 and directors interested in running for EC must contact APHA.

**April 1**

Contact the Director of Youth Activities if you plan to run for the 2004-2005 AjPHA Executive Committee.

**May 15**

\*Youth Member of the Year application deadline.

World Championship Horse Judging Contest entry deadline (entry must be postmarked on or before May 15).

\*Youth Team Tournament (entry must be postmarked on or before May 15).

\*Great Paint Brush Off (Art Contest) entry deadline (postmark).

\*Presidential Service Project, From the Heart Award entry deadline (postmark).

**June 3-5**

APHA Workshop, Harvey Hotel, Irving, Texas.

**October 1**

\*Essay Contest entry deadline (postmark).

**September 30-October 2**

APHA Annual Convention - Tucson, Arizona.

**October 1-2**

AjPHA National Leadership Conference - Tucson, Arizona.

\*Entry form is available on the AjPHA web site or from the APHA Youth Coordinator.



## 2004 Paint Horse Calendar

To order call toll free  
(877) 460-6275, or  
visit us online at  
[apha.com/store](http://apha.com/store)

- 1 calendar—\$9.95
- 2 calendars—\$18
- 3 calendars—\$25
- 4 or more—\$8 each



## APHA FORMS & GUIDES (NO CHARGE)

AjPHA Application \_\_\_\_\_  
AjPHA Regional Club list \_\_\_\_\_  
Amateur Card Application \_\_\_\_\_  
Breeder's and Trainer's Directory \_\_\_\_\_  
Breeder's Trust Foal Nomination \_\_\_\_\_  
Breeder's Trust Sire Subscription \_\_\_\_\_  
Breeding Guide \_\_\_\_\_  
Color Coat Genetics Guide \_\_\_\_\_  
Colors and Patterns Poster \_\_\_\_\_  
Corrected Registration Certificate Form \_\_\_\_\_  
DNA Genetic Hair Kit Form \_\_\_\_\_  
Duplicate Certificate Affidavit \_\_\_\_\_  
General Store Catalog \_\_\_\_\_  
Horse Show Handbook (for show managers) \_\_\_\_\_  
*Journal* Rate Cards \_\_\_\_\_  
Judge Application \_\_\_\_\_  
Lease Forms \_\_\_\_\_  
Membership/*Journal* Subscription /Application Forms \_\_\_\_\_  
Name Change Form \_\_\_\_\_  
Overo/Tobiano Color Prints \_\_\_\_\_  
PAC Enrollment Form \_\_\_\_\_  
Paint Racing Brochure \_\_\_\_\_  
Parts of the Horse \_\_\_\_\_  
Program & Competition Guide \_\_\_\_\_  
Recreational Riding Guide \_\_\_\_\_  
Recreational Trail Riding Application Form \_\_\_\_\_  
Regional Club Application \_\_\_\_\_  
Regional Club list \_\_\_\_\_  
Registration Application/Breeder's Certificate Blanks \_\_\_\_\_  
Registration Guide \_\_\_\_\_  
Ride America Enrollment Form \_\_\_\_\_  
Semen Transport Application \_\_\_\_\_  
Show Application Form \_\_\_\_\_  
Show Calendar (tentative) \_\_\_\_\_  
Signature Authorizations \_\_\_\_\_  
Stallion Breeding Report Form \_\_\_\_\_  
Stallion Listing Cards (QH or TB) \_\_\_\_\_  
Status Change Form \_\_\_\_\_  
Transfer Forms \_\_\_\_\_  
Youth Exhibitor Identification Card Application \_\_\_\_\_  
Youth Exhibitor Novice Card Application \_\_\_\_\_

**For forms contact the American Paint Horse Association at Ext. 261 or for 24 hour service call Ext. 271 or go to [www.apha.com/forms](http://www.apha.com/forms).**

**For promotion items sold through the APHA contact the American Paint Horse Association at Ext. 300 or refer to [www.apha.com/store](http://www.apha.com/store).**

**TABLE OF CONTENTS**  
**APHA CORPORATION BY-LAWS**

	<b>Paragraph</b>	<b>Page</b>
Amendments	VII	26
APHA Racing Affiliates	XII	30
Corporate Seal	I	18
Directors	III	19
Duties/Officers	V	24
Executive Committee	IV	23
International Associations	XIII	31
Location	I	18
Members	II	18
Objectives	I	18
Officer & Duties	V	24
Parliamentary Authority	VI	26
Recall	VIII	26
Regional Clubs	IX	27
Special Interest Clubs	X	29
Title	I	18
AjPHA Regional Clubs	XI	30

**GENERAL RULES AND REGULATIONS**

APHA Funds	GR-055	40
Committees (Standing)	GR-005	32
Disciplinary Procedure	GR-070	43
Facsimile Transmissions	GR-071	45
Fraudulent Practices	GR-065	42
Liability	GR-045	39
Membership	GR-020	34
AjPHA	GR-020.I	37
Annual	GR-020.G	36
J-Term	GR-020.J	37
Life	GR-020.H	36
Multi-Year	GR-020.K	37
Proposed Rule Changes	GR-010	32
Release of Liability	GR-050	39
Responsibility	GR-040	38
Television and Media Rules	GR-030	37
Unsportsmanlike Conduct	GR-066	43
Violations	GR-060	41

**REGISTRATION RULES AND REGULATIONS**

Advancement	RG-025	54
Stallions, Geldings, Mares	RG-025	54
Affidavits of Heirship	RG-080.F	62
Age Computation	RG-095	64
Artificial Insemination, Cooled & Frozen Semen Transportation	RG-165	77
Bloodline Requirement	RG-015	48
Breeder/Breeder's Certificate	RG-045	56
Color Requirements	RG-110	66
Deaths	RG-155.F	74
Divorces	RG-155.G	74
Duplicate or Corrected Certificates	RG-135	70

	<b>Paragraph</b>	<b>Page</b>
Embryo Transplants	RG-170	79
Fees	RG-050	58
Rush Fee	RG-050.D	58
Processing Fee	RG-050.C	58
Forfeiture of Fees	RG-175	81
Computer Flagging Fee	RG-050.E	58
Gelded Horses	RG-125	70
General Procedures for Handling		
Registration Applications	RG-055	59
General Registration Requirements	RG-070	60
Genetic testing by DNA	RG-160/RG-040.E	76/56
Inspection Procedures	RG-115	68
Leases	RG-085	62
Listing Requirements (APHA, AQHA or TB Stallions)	RG-035	54
Membership	RG-075	61
Name Changes	RG-105	65
Naming a Horse	RG-100	65
Pedigree Certification	RG-160.C	77
Photograph Requirements	RG-090	63
Picture Replacement	RG-135.H	71
Re-Activations	RG-180	81
Registration Decisions	RG-065	59
Registration Review Committee	RG-060	59
Registries (The)	RG-020	49
Regular	RG-020.A	49
Breeding Stock	RG-020.B	49
Identification Status	RG-020.C	50
Re-Registrations	RG-150	73
<i>Appendix/International</i>	<i>RG-021</i>	<i>50</i>
Scars & Brands	RG-121	69
Signature Authorizations	RG-080	61
Stableman's Lien Transfer	RG-155.M.	75
Stallion Breeding Reports (SBR)	RG-040	55
Status Changes	RG-145	72
Stud Book (The)	RG-010	48
Surrender of Certificate	RG-140	72
Tattooing	RG-130	70
Tooth Examination	RG-095.C	64
Transfer of Ownership	RG-155	73
Unnatural Markings	RG-120	68

## GENERAL SHOW & CONTEST RULES AND REGULATIONS

Age Requirements	SC-170	116
All Around Award	SC-145	108
APHA Champion Award	SC-035	84
APHA Honor Roll Award	SC-040	85
APHA Open Top Twenty Award	SC-045	85
APHA Performance Versatility Award	SC-025	83
APHA Register of Merit Award	SC-050	86
APHA Superior All-Around Horse	SC-020	83

	<b>Paragraph</b>	<b>Page</b>
APHA Superior (Event) Award	SC-030	.84
APHA Supreme Champion	SC-015	.82
APHA Titles & Awards	SC-010	.82
Barrel Racing	SC-290	.188
Breeding Stock Rules	SC-325	.194
Calf Roping	SC-280	.185
Classification of Shows	SC-055	.87
Cow Pony Race	SC-300	.193
Cutting	SC-286	.188
Drugs & Medication	SC-085	.91
English Attire & Personal		
Appointments	SC-195	.127
English Tack	SC-200	.128
Exhibitor Conduct	SC-070	.89
General Show Rules	SC-160	.113
Go-Rounds	SC-185.J.	.122
Grand and Reserve Champions	SC-065	.88
Green Working Hunter	SC-216	.134
Group Halter Classes	SC-180	.120
Hackamore	SC-240.D.	.141
Halter Class General Rules	SC-175	.117
High Point Performance Horse	SC-150	.113
Hunter Hack	SC-210	.131
Hunter Under Saddle (BPH)	SC-205	.129
Inhumane Treatment	SC-075	.89
Jumping	SC-220	.134
Lameness.	JU-000.H.4./SC-160	.202/113
Minimum Requirements for Shows	SC-095	.98
Multiple-Judge Shows	SC-105	.106
Paint-O-Ramas	SC-105.B.2	.106
Performance Contests	SC-190	.123
Performance General Rules	SC-185	.121
Pleasure Driving	SC-225	.137
Points	SC-060	.87
Pole Bending	SC-295	.190
Premium Lists & Prizes	SC-120	.110
Prohibited Procedures	SC-080	.89
Registration Requirements for		
Halter & Performance	SC-165	.116
Reining	SC-260	.157
Ribbons	SC-155	.113
Ring Steward	SC-135	.111
Show Approval	SC-090	.95
Show Manager	SC-110	.109
Show Results	SC-125	.110
Show Secretary	SC-115	.109
Single Judge Show	SC-100	.106
Special APHA Paint Events	SC-096	.98
Special Notice & Effective Date	SC-005	.82
Stake Race	SC-296	.192
Team Roping/Steer Stopping	SC-285	.186
Team Penning	SC-275	.182
Trail	SC-250	.147

	<b>Paragraph</b>	<b>Page</b>
Utility Driving	SC-230	138
Veterinarian	SC-140	112
Western Attire	SC-235	141
Western Attire & Tack		
Roping, Speed & Team Penning)	SC-270	181
Western Pleasure	SC-245	144
Western Riding	SC-255	150
Western Tack	SC-240	141
Working Cowhorse	SC-265	170
Working Hunter	SC-215	131
Working Ranch Horse Competition	SC-096.B.	98
Yearling Longe Line	SC-191	124
Zone-O-Ramas	SC-105.B.3	107
Zone Top 5 Award	SC-046	86

## JUDGES

Judges	JU-000	198
--------	--------	-----

## AMATEUR PROGRAM

Age Divisions	AM-080	212
All-Around Award	AM-100	215
Amateur Champion Award	AM-040	208
Amateur Honor Roll Award	AM-065	211
Amateur Performance		
Versatility Award	AM-045	209
APHA Amateur Register of Merit	AM-055	210
Amateur Superior Event Horse Award	AM-050	209
Amateur Titles & Awards	AM-025	206
Amateur Top Twenty	AM-060	210
Amateur Zone Award	AM-070	211
Application or Renewal	AM-015	205
Breakaway Roping	AM-120	225
Eligibility	AM-010	204
General Show Rules	AM-085	213
Goat Tying	AM-125	226
Halter	AM-090	213
Hunt Seat Equitation	AM-110	218
Interpretation of Rules	AM-005	204
Ownership	AM-020	206
Performance Contest Categories	AM-030	207
Performance & Equitation Classes	AM-095	214
Rookie of the Year Award	AM-071	211
Show Approval Rules	AM-075	212
Showmanship at Halter	AM-105	215
Superior Amateur		
Championship Award	AM-035	208
Team Roping	AM-135	227
Western Horsemanship Equitation	AM-115	220

## NOVICE AMATEUR PROGRAM

APHA Novice Amateur Honor Roll	AM-225	229
APHA Novice Amateur		
Register of Merit	AM-235	230

	<b>Paragraph</b>	<b>Page</b>
Novice Amateur Superior Event Horse	AM-220	229
APHA Novice Amateur Top Twenty	AM-230	229
APHA Novice Amateur Zone Award	AM-240	230
Application Renewal	AM-210	228
Eligibility	AM-205	228
General Show Rules	AM-245	230
Interpretation of Rules	AM-200	228
Novice Amateur Titles & Awards	AM-215	229
Performance/Equitation Categories	AM-250	230

### **YOUTH PROGRAM**

APHA Superior Youth		
Champion Award	YP-030	235
APHA Youth Champion Award	YP-035	235
APHA Youth Honor Roll Awards	YP-060	238
APHA Youth Register of Merit Award	YP-050	237
APHA Youth Superior Event Horse	YP-045	236
APHA Youth Titles & Awards	YP-020	233
APHA Youth Top Twenty Award	YP-055	237
APHA Youth Versatility Performance		
Award	YP-040	236
APHA Youth Zone Award	YP-065	238
All Around Youth Award	YP-095	242
Breakaway Roping	YP-135	259
Breeding Stock Youth		
Showmanship at Halter	YP-101	245
Calf Roping	YP-130	259
Class and Show Approval	YP-070	238
Cutting		
(NCHA & CCHA Youth Division)	YP-150	261
Eligibility	YP-010	232
Goat Tying	YP-140	260
Halter	YP-085	240
Hunt Seat Equitation	YP-115	246
Lead-Line (Equitation)	YP-105	245
Married Contestants	YP-010.B	232
Membership	YP-005	232
Ownership	YP-015	233
Performance Contest Categories	YP-025	234
Performance & Equitation Events	YP-090	241
Registration Requirements	YP-020.B	233
Reining	YP-125	254
Showmanship at Halter	YP-100	242
Team Roping	YP-137	260
Walk-Trot (Equitation)	YP-110	246
Western Horsemanship Equitation	YP-120	249
Youth Age Divisions	YP-075	239
Youth Program General Rules	YP-080	239

### **NOVICE YOUTH PROGRAM**

Application/Renewal	YP-210	262
Card Application or Renewal	YP-255	264
Eligibility	YP-205	262

	<b>Paragraph</b>	<b>Page</b>
General Show Rules	YP-245	263
Novice Youth Division	YP-200	262
Performance/Equitation Categories	YP-250	263
Titles and Awards	YP-215	262

### **RACING**

APHA Racing Recognition Program	RA-060	269
Cutter and Chariot Racing	RA-070	271
Disclaimer	RA-080	271
Enhancement of Penalty Rule	RA-020	267
Horse Ownership	RA-030	268
Rules and Regulations	RA-000	265
Speed Index & Racing Points	RA-010	266
Stakes Races	RA-050	269
Tattoo, Identification Requirements and Parentage Verification	RA-040	268

### **PAC (Paint Alternative Competition)**

PAC Approved Categories	PR-060	277
PAC Certificate of Achievement	PR-020	276
PAC Certificate of Recognition	PR-010	276
PAC Leaders	PR-030	276
Six PAC Champion	PR-050	277
Six PAC Top Five	PR-040	276
Competitive and Endurance Trail Riding		278

### **AjPHA CONSTITUTION**

Advisory Board	VI	286
AjPHA Zones	X	287
Amendments	VIII	286
Committees	IX	287
Directors	III	281
Executive Committee	IV	284
Membership	II	280
Name & Purpose	I	280
Place of Business	VII	286
Recall	V	286

### **ADDITIONAL FEATURES**

<b>AjPHA PROGRAMS</b>	289
<b>APHA DEPARTMENT EXTENSIONS</b>	301-302
<b>COLOR PATTERNS</b>	291-292
<b>DESCRIPTION OF COLORS</b>	290-291
<b>EXECUTIVE COMMITTEE</b>	300
<b>EQUIPMENT &amp; ATTIRE CHART</b>	294-298
<b>KEY FOR ALL DIAGRAMS, if applicable</b>	298
<b>IDENTIFICATION GUIDE</b>	293
<b>INTERNATIONAL AFFILIATES</b>	299
<b>RECREATIONAL RIDING GUIDELINES</b>	274
<b>MAP TO APHA</b>	303
<b>MEMBERSHIP APPLICATION</b>	304
<b>METRIC SYSTEM</b>	290
<b>PAINT HORSE CALENDAR AD</b>	8
<b>RIDE AMERICA PROGRAM</b>	280

## AMERICAN PAINT HORSE ASSOCIATION MISSION STATEMENT

**Our mission** is to collect, record and preserve the pedigrees of American Paint Horses and to stimulate and regulate all matters that pertain to the promotion, history, breeding and exhibition of this breed.

**Our success** depends upon our ability to provide fiscally responsible and efficient services to our members.

**We aspire** to excellence in record keeping, reporting, recruiting, educating and supporting our membership, so that we may inspire confidence and create in them a desire to use our services.

**We serve** both the breed and our members by being ever aware of the industry and market, and of the needs, opportunities and challenges of our members.

**We value:**

- the American Paint Horse and those people who treat them gently, humanely and with respect.
- the unique skills and talents of our members.
- the equine industry and working with other organizations to achieve shared goals and ideals.
- those who conform to accepted form-to-function conformation standards, which contribute to the breed's versatility.
- all programs and services that promote a rich family life for our members and encourage leisure activities, recreation and fun.
- long range planning, sound financial policies and continued investment in the future of APHA.

**We strive:**

- to keep careful, accurate, neat records in all activities.
- to increase public awareness of the breed.
- to record, maintain and disseminate information on an international scale.
- to remain accountable to our members by communicating our actions, programs and progress on a regular basis.
- to serve as a liaison and speak boldly, clearly and persuasively on behalf of the breed and our members.
- to monitor industry trends through input from directors, regional clubs and members.
- to evaluate APHA's current programs and predict future needs.
- to assist and be accessible to our members.
- to perform our duties in a timely and efficient manner.

## FOREWORD

The organization we know as the American Paint Horse Association was formed as the American Paint Stock Horse Association in 1962 to collect, record and preserve the pedigrees of Paint Horses. The growth of the breed in numbers, in stature and in public acceptance is an indication of the fulfillment of the need. The book you have in your hands is an updated and reorganized printing of the rules that have been established to further the progress of the breed.

On June 3, 1965, the American Paint Stock Horse Association and the American Paint Quarter Horse Association consolidated to form the AMERICAN PAINT HORSE ASSOCIATION. Hereafter, the APHA included all horses with registration papers in the APSHA and APQHA.

This edition of the APHA Official Rule Book contains the governing rules pertaining to registration, shows, races, youth and amateur programs, and provisions for Breeding Stock competition, in addition to the AjPHA Constitution and APHA Corporation By-Laws.

### **APHA Position Statement on Animal Welfare**

The American Paint Horse Association is committed to the humane and proper treatment of all animals. In this respect;

- The welfare of the horse is the primary consideration in all activities.
- Horses will be treated with kindness, respect and compassion at all times.
- Responsible care will be used by all parties in handling, treatment and transportation of horses.
- Horse men and women as owners, exhibitors or trainers will ensure the health and well being of animals in their care at all times.
- The standard by which conduct or treatment will be measured is that which a reasonable person, informed and experienced in generally accepted animal husbandry standard and equine care, training and exhibition procedure would determine to be neither cruel, abusive nor inhumane.

Based on their principles, the Association has developed and enforces strict rules to ensure ethical competition and humane treatment of American Paint Horses. The Association supports the development of procedures that assure equity, fairness, safety, health and welfare for all participants.

Because the Association is strongly opposed to animal abuse, any member convicted in a court of law of cruelty to animals may be suspended from the APHA when certified evidence is presented to the Executive Committee.

### **The APHA's Disclaimer of Responsibility For Safety**

APHA does not assume responsibility for safety of participants at the shows or other events it sanctions.

Safety is a concern of everyone, but APHA does not assume responsibility for it. APHA's limited purpose for sanctioning or approving a show is to promote fair competition. Show management is responsible for participant safety.

## APHA BY-LAWS

### AMERICAN PAINT HORSE ASSOCIATION BY-LAWS AS AMENDED OCTOBER 1, 2003

#### ARTICLE I

##### Title, Objectives, Location, Corporate Seal

**Section 1.** Title: This Association shall be known as the **American Paint Horse Association, Inc.**, (“Association”) and shall at all times be operated and conducted as a non-profit association in accordance with the laws of the State of Texas, providing for such organizations and by which it shall acquire all such rights as granted to associations of this kind.

**Section 2.** Objectives: The purpose of this Association shall be to collect, record and preserve the pedigrees of Paint Horses, to publish a registry, and to stimulate and regulate any and all other matters such as may pertain to the history, breeding, exhibition, publicity, sale, racing or improvements to this breed.

**Section 3.** Place of Business: The principal place of business shall be Fort Worth, Tarrant County, Texas, but its members or officers may be residents of any state, territory or county, and business may be carried on at any place convenient to such members or officials as may be participating.

**Section 4.** Corporate Seal: The seal of the Association shall be in the charge of the Executive Secretary.

#### ARTICLE II

##### Members

**Section 1.** Members of the Association shall be admitted, retained, suspended and expelled in accordance with such rules and regulations as the Board of Directors may, from time to time, adopt. In all matters governed by the vote of the members, each member in good standing shall be entitled to one vote, except that in the election of national directors, members in good standing as of February 1 of the current year shall be entitled to vote.

**Section 2.** The regular annual meeting of the membership shall be held at such time and place as may be fixed by resolution of the membership. Notice of the annual meeting shall be published in the *Paint Horse Journal*.

**Section 3.** Special meetings of the members may be held at such time and place as may be designated in the notice, whenever called in writing by direction of the President or by a majority of the Board of Directors, or by notice signed by not less than twenty percent of the members then in good standing. Notice of each meeting indicating briefly the subject or objects thereof shall be given in the same manner as provided with respect to notice of annual meetings.

**Section 4.** At any meeting of the members held in accordance

with the foregoing provisions as to notice, the members attending such meeting shall constitute a quorum of the members for all purposes unless the representation of a larger number should be required by law. In that case the representation so required shall constitute a quorum. Absentee or vote by proxy is not allowed in the annual membership meeting or any special membership meeting.

**Section 5.** Any officer of the Association may call the meeting of the members to order and may act as chairman of such meeting, precedence being given as follows: President, President-Elect, and Vice President.

The Executive Secretary of the Association shall act as secretary of the Association of all meetings of the members, but in his absence the Acting Chairperson may appoint any person to act as secretary of the meeting.

**Section 6.** Whenever in these By-Laws the term member or members shall be used, unless otherwise specified, it shall mean a member(s) in good standing having the right to vote.

### **ARTICLE III Directors**

**Section 1.** The business and property of the Association shall be managed and controlled by the Board of Directors, and an Executive Committee hereinafter created and empowered.

The By-Laws and rules affecting registration of horses shall be subject to change only by the Board of Directors.

#### **Election of Directors**

- A. The Association shall have approximately 100 elected directors.
- B. Approximately one-half of the directors from each Representative Area will be elected annually and shall hold office for a term of two (2) years or until their successors are elected and have taken office at the adjournment of the current year Annual Convention Board of Directors meeting.
- C. To determine the total number of directors to be elected in any election year and the manner in which such directors shall be allocated among the Representative areas, the following steps shall be taken:
  1. The number of director allocations of a Representative Area shall first be determined in accordance with the formula as set forth in Steps 2-5 below to determine the number of director allocations of a Representative Area.
  2. The total membership of the Association shall first be divided by 100.
  3. Then, the total membership of each Representative Area shall be divided by the amount obtained in Step 2 above, with the resulting quotient being calculated to the one-thousandths decimal place.
  4. The amount obtained in Step 3 above, shall then be rounded to the nearest whole number. Such number shall represent the total number of director allocations of a Representative Area.
  5. To allow for mathematical variances, the total number of

elected directors of the Association, may vary from 97 to 103. The President may also at his discretion appoint up to five (5) additional directors to serve during his term of office.

6. The number of directors that shall be elected from a Representative Area in any given year shall be equal to the difference between the amount determined in Step 4 above and the number of directors of such Representative Area whose terms of office do not expire in such election year.
  7. The APHA office shall determine annually if it shall be necessary for any specific number of directors from a Representative Area to be elected for a term of only one (1) year to effectuate the desired result that approximately one-half of the directors from each such area be elected annually and shall direct such necessary variance in the terms of election.
- D. Director reallocation shall be made annually as of December 31 of the year immediately preceding the election year. Each member in good standing, defined as a member currently free of disciplinary restrictions, whose application for membership is postmarked no later than February 1 of the year the election is conducted shall receive a ballot for their representative area and shall be entitled to one vote.
- E. The term “Representative Area” shall be defined as each state of the United States or any *international* country or any political subdivision of such foreign country having the sufficient number of members required. When any state, province or any foreign country has less than the required number of members for a director at the time of allocation, it shall be grouped with one or more other states, countries, etc. to form a Representative Area in order to reach the minimal number of members required for a director allocation. At no time may a Representative Area have more than twenty-five percent (25%) of the total directors, excluding Directors-at-Large.
- F. A Directors Nominating Committee, which must be comprised of elected Directors or Directors-at-Large, separate from the National Officers Nominating Committee, shall be appointed by the President and publicly announced by March 1 of each year.
1. Recommendations for nominations from Regional Clubs will be received by the Directors Nominating Committee. In addition, an individual may recommend him/herself for nomination upon submission of the signatures of five APHA current members in good standing and residing in the same Representative Area evidencing endorsement of the recommendation.
  2. To be eligible, each individual nominated and/or elected to serve shall be a bona fide resident of his Representative Area and a current APHA member in good standing.
  3. There may be only one director/alternate nominated or elected per membership.
  4. The Regional Club recommendations and individual recommendations for directors must be forwarded to the national office and bear postmark date of no later than

- February 15 of the election year.
5. The Director Nominating Committee shall prepare a ballot for each Representative Area taking into consideration nominations from individual recommendations, regional club recommendations and recommendations from members of the nominating committee.
  6. After February 15 of the election year, the Directors Nominating Committee shall mail the ballot of each Representative Area to all of the members of such Representative Area. Ballots must be returned according to director election procedures.
- G. The nominee(s) will be designated director(s) or alternate(s) according to the number of votes received for each nominee on the ballot. The nominee(s) receiving the highest number(s) of votes will be designated director(s) after which the alternate(s) will be designated according to the remaining number of votes in descending order for positions needed, if applicable. Each area with four (4) or less directors will be allowed one (1) alternate to serve for one (1) year. Areas with five (5) or more directors will be allowed a maximum of two (2) alternates to serve for one (1) year. If an area is entitled to an alternate only the nominee receiving the highest number of votes will be named alternate for a Representative Area.
1. When there are fewer nominees on the ballot than needed for the director and/or alternate position(s) in a Representative Area, the President may appoint the unfilled position(s) for that Representative Area.
  2. Alternates will be appointed to standing committees with full voting privileges therein, but would only have director voting privileges in the absence of a director from their Representative Area.
- H. In addition to the directors so elected, all Past Presidents, the President and the President-Elect of the Association shall be and become Lifetime Directors-at-Large with voting privileges.
- I. In addition to the directors so elected, each past and future Distinguished Service Award shall include a Lifetime Directorship at Large with voting privileges.
- J. The Board of Directors for the coming year must be determined by June 1 of the election year. Directors shall take office upon installation of officers, which shall occur upon adjournment of the current year Annual Convention Board of Directors meeting.

**Section 2.** In case of any vacancy in the Board of Directors by death, resignation or any other cause, the president shall appoint a successor from the same area in which the vacancy occurs to serve the remainder of the unexpired term.

**Section 3.** A director/alternate must attend 1/2 of the required APHA directors meetings per 12-month period and answer roll call at the time it is taken to assure a record of their attendance. Failing to do this, the director/alternate may be replaced at the discretion of the President.

**Section 4.** The regular annual meeting of the Board of Directors shall be held immediately following the annual members'

meeting, and no notice shall be required for any such regular meeting of the Board. The Board, by rule, may provide for other regular meetings at stated times and places, of which no notice shall be required. Absentee or vote by proxy is not allowed in any meeting of the Board of Directors.

**Section 5.** Special meetings of the Board of Directors shall be held whenever called by the direction of the President, or by two-thirds of the directors in office at that time.

The Executive Secretary shall give notice of each special meeting by mailing or telephoning the same to each director at least fifteen (15) days before the meeting, but such notice may be waived by any director. Unless otherwise indicated in the notice thereof, any and all business may be transacted at a special meeting.

Any business may be transacted at any meeting at which every director may be present, even if the meeting was called without any notice.

**Section 6.** Fifty-one directors shall constitute a quorum for the legal transaction of business, but if at any meeting of the Board there may be less than fifty-one directors present, a majority of those present may adjourn the meeting from time to time until a quorum shall be present.

**Section 7.** At meetings of the Board of Directors, business shall be transacted in such order as the Board may determine.

**Section 8.** At the regular annual meeting of the Board of Directors, the Board shall proceed to the election of officers of the Association.

**Section 9.** The Board of Directors shall have the power and authority to make, amend, repeal and enforce such rules and regulations, not contrary to law or the Certificate of Incorporation or these By-Laws, as they may deem expedient concerning the conduct, management and activities of the Association, the admission, classification, qualification, suspension and expulsion of members, removal of officers, the rules and regulations governing the procedure of such suspension and expulsion and removal, the fixing and collecting of dues and fees, regulations regarding stud book listings, registrations, awarding of championships, the conducting of shows, contests, exhibitions, races, sales and social functions and all other details relating to the general purposes of the Association.

**Section 10.** All actions of the Board of Directors are subject to revision or amendment by the members at any special or regular meeting of the membership provided that written notice of any intention to revise or amend has been published in the *Paint Horse Journal* at least thirty (30) days in advance of that meeting.

**Section 11.** The Board of Directors, from time to time, may create and empower other committees, general or special.

**Section 12.** No director of the APHA shall be liable to the APHA or its members for monetary damages for an act or omission in such director's capacity as a director of the APHA, except that this Article shall not eliminate or limit the liability of a director of the APHA for:

- A. A breach of such director's duty of loyalty to the APHA or its members;
- B. An act or omission not in good faith or that involves intention-

- al misconduct or a knowing violation of the law;
- C. A transaction from which a director received an improper benefit, whether or not the benefit resulted from an action taken within the scope of the director's office; or
  - D. An act or omission for which the liability of a director is expressly provided for by statute.

**Section 13.** Any repeal or amendment of this Article by the members of the APHA shall be prospective only, and shall not adversely affect any limitation on the personal liability of a director of the APHA existing at the time of such repeal or amendment. Anything herein to the contrary notwithstanding, if the Texas Miscellaneous Corporation Laws Act is amended after approval by the members of this Article to authorize corporate action further eliminating or limiting the personal liability of directors, then the liability of a director of the APHA shall be eliminated or limited to the fullest extent permitted by the Texas Miscellaneous Corporation Laws Act, as so amended from time to time.

## **ARTICLE IV**

### **Executive Committee**

**Section 1.** There is hereby created an Executive Committee consisting of the President, President-Elect, Vice President, the Immediate Past President and three additional members. These officers and additional members shall be elected by and from the current Board of Directors at the annual meeting of the Board, each for a term of one year and until the selection and qualification of his successor.

- A. The President shall appoint and publicly announce a Nominating Committee for Officers and the Executive Committee, which must be comprised of elected Directors or Directors-at-Large, by May 1 of the election year. Their nominations shall be published in the *Paint Horse Journal* at least thirty (30) days prior to the annual convention.
- B. The President is hereby empowered to appoint five advisors, without voting power, to the Executive Committee. Any member of the APHA in good standing shall be eligible for selection as advisor.
- C. Upon election to the Executive Committee, the elected members or officers shall automatically become directors-at-large and shall remain a director-at-large for so long as they are re-elected to the Executive Committee, or until reaching the position of president-elect, thus becoming a lifetime director-at-large. By virtue of becoming a director-at-large, a vacancy will be created. The vacancy that is created from the remainder of the newly elected Executive Committee member's term shall be filled by Presidential appointment from the newly elected Executive Committee member's state, area or province or by normal director election procedures in the next election. Should a member of the Executive Committee fail to be re-elected to the Executive Committee, he/she must be nominated as prescribed in the Official Handbook and run for the national director position, if available, as prescribed in Article III (i.e., will no longer be a director-at-large). (See Article III.H.

for lifetime director-at-large.)

**Section 2.** No officer or member of the Executive Committee may serve on the Executive Board in excess of seven consecutive years.

**Section 3.** The President shall fill all vacancies in the required number of members of the Executive Committee occurring between annual meetings of the Association.

**Section 4.** The Executive Committee shall meet whenever and wherever called by direction of the President or three members of the Committee acting jointly, of which each meeting the Executive Secretary shall give ten (10) days written notice, but such notice may be waived by any member. Absentee or vote by proxy is not allowed in any meeting of the Executive Committee.

**Section 5.** The Committee may act without convening in meeting by written resolution signed by all the members thereof and duly entered in the Association's records. At all meetings of the Committee, four members shall constitute a quorum.

**Section 6.** All powers of the Board of Directors, except the power to change any By-Laws pertaining to registration of horses, and any rule and regulation pertaining to registration of horses, be and the same are hereby vested, in the Executive Committee. All actions of the Executive Committee, with the exception of disciplinary actions resulting from hearings, are subject to ratification, revision or amendment by the directors at any regular or special meeting of the Directors.

**Section 7.** It shall be the responsibility of the Executive Committee to direct the handling of questionable horse registration applications, to direct all other Association business matters, to furnish liaison members to all Standing Committees, to report to the Board of Directors at its annual meetings, to interview persons for the position of Executive Secretary and employ a person as Executive Secretary.

**Section 8.** The Executive Committee shall be responsible for interpreting and deciding all questions or ambiguities that may arise in connection with the meaning, intent or purpose of any by-law, rule, regulation or other APHA document.

**Section 9.** All members of the Executive Committee shall be governed by the Code of Ethics included in the APHA Organizational Handbook.

## **ARTICLE V**

### **Officers and Duties**

**Section 1.** Officers: The Officers of the Association shall be the President, President-Elect, Vice President, Executive Secretary and such other officers as may be authorized from time to time by the Board of Directors.

**Section 2.** Eligibility: Only members of the Board of Directors shall be eligible to serve as officers of the Association. The President-Elect must be elected from the current Executive Committee. The Executive Secretary need not be a member of the Board of Directors.

**Section 3.** Election: The officers of the Association shall be elected by majority vote by the Board of Directors. Anything here-

in to the contrary notwithstanding, the Executive Secretary shall not be elected by the Board of Directors, but shall be employed by the Executive Committee.

**Section 4.** Term: Unless otherwise specified in any employment contract approved by the Board of Directors, the officers of the Association shall hold office for a period of one (1) year or until their successors are elected and have taken office upon the adjournment of the current year Annual Convention Board of Directors meeting.

**Section 5.** Duties:

- A. **President:** The President shall be the Chief Executive Officer of the Association and shall preside at all meetings of the Board of Directors. He shall see that the By-Laws, rules and regulations of the Association are enforced and shall perform all other duties that may be prescribed from time to time by the Board of Directors. He shall be an ex-officio member of all committees.
- B. **President-Elect:** In the absence of the President, the President-Elect shall have the power and shall perform the duties of the President and such other duties as may be prescribed by the Board of Directors. Upon the expiration of the President's term of office, the President-Elect shall automatically become President.
- C. **Vice-President:** In the absence of the President and the President-Elect, the Vice-President shall have the power and shall perform the duties of the President and such other duties as may be prescribed by the Board of Directors.
- D. **Executive Secretary:** The Executive Secretary shall be responsible for seeing that the minutes of all membership and directors meetings are kept; for the safekeeping of all documents and records of the Association and authority for pedigrees; for executing the certificates of pedigree demanded and proper to be issued by this Association and for record-keeping of those items. He shall also be responsible for seeing that all money due the Association is collected and for compiling the American Paint Horse Stud Book Registry. He shall be an ex-officio secretary of all Committees appointed by the President or Board of Directors. He shall make a report of his office to the Board of Directors when demanded and to all annual membership meetings, and shall perform such other duties as may be prescribed by the Board of Directors from time to time. In addition, the Executive Secretary shall disburse the money of the Association; however, only upon itemized demands and upon the order of the Executive Committee. He shall account for all of the same by itemized statements in detail to each annual meeting of the members and the Board of Directors when demanded. Also, he shall cause to be submitted to the Executive Committee, at a meeting date designated by the Executive Committee, a detailed budget of the proposed and anticipated expenditures for the forthcoming fiscal year of the Association. Upon approval of this said budget, or its modification, it becomes binding upon the officers of the Association, and cannot be exceeded in the total amount set forth by more than ten percent without a majority vote of the Executive

Committee.

**Section 6.** The written contracts of the Association shall be executed on behalf of the Association by the President or President-Elect and attested by the Executive Secretary and the corporate seal.

**Section 7.** Vacancies: All vacancies of the officers of the Association, except where provided elsewhere, shall be filled by and from the Executive Committee for the unexpired term and those so appointed shall serve until the election and acceptance of their duly qualified successors.

**Section 8.** Auditing of Accounts: This Association shall conduct its affairs on a calendar year basis, same to begin January 1 and end on December 31.

An annual commercial auditing of the accounts of the Executive Secretary shall be made by a certified public accountant at the close of each calendar year and shall be reported to the next annual meeting of the members following the close of each calendar year. Such accountant shall be a disinterested person and not a member of the Association.

**Section 9.** Surety Bonds: The Secretary and the Treasurer and all other officers or employees of the Association who may handle any funds of the Association shall give a surety bond to be furnished at the expense of the Association for the faithful discharge of his or her duties if so required by the Executive Committee.

## **ARTICLE VI**

### **Parliamentary Authority**

The rules contained in the current edition of Roberts Rules of Order, Newly Revised shall govern the Association in all cases to which they are applicable and in which they are not inconsistent with these bylaws and any special rules of order the Association may adopt.

## **ARTICLE VII**

### **Amendments**

The Board of Directors shall have the power to make, amend and repeal the By-Laws of the Association by vote of the majority of the Directors at any regular or special meeting of the Board, subject to the right of the members to rescind or amend any such By-Laws in the same manner as provided in Section 10, Article III, for the Revision or Amendment of Rules and Regulations.

## **ARTICLE VIII**

### **Recall**

**Section 1.** Any member of the Executive Committee may be removed from office with or without cause as herein provided. A recall petition(s) demanding the removal of such officer shall be submitted to the Executive Secretary of the Association. Such recall petition(s) shall be signed by at least twenty-five percent (25%) of the current members of the Board of Directors.

**Section 2.** Petition forms shall be provided to any Director

requesting same following the filing of an affidavit by one or more Directors with the Executive Secretary stating the name of the Director or officer sought to be removed. The Executive Secretary shall record the name of the director to whom petition forms were issued, the date of such issuance and the number of forms issued, certifying on each form the date and the name of the director to whom it was issued.

**Section 3.** All forms comprising a recall petition shall be assembled and filed with the Executive Secretary within forty-five (45) days after the filing of the affidavit required in Section 2 above. The signature of the petitioners shall be properly notarized.

**Section 4.** In the event that the required number of properly verified signatures to said recall petition are not received by the Executive Secretary within forty-five (45) days of the affidavit filing required in Section 2, above, the Executive Secretary shall notify those directors having filed petitions that the recall petition was insufficient and that said insufficiency does not prejudice the filing of a new affidavit for the same purpose.

**Section 5.** Not more than five (5) days following determination by the Executive Secretary that the petition(s) received are sufficient, he shall notify in writing the officer whose removal is sought by such action. This notice shall be delivered in hand or shall be delivered by certified mail. If said officer does not render his resignation within seven (7) days of receipt of such notice, the Executive Secretary shall within fifteen (15) days of the aforesaid determination, direct and conduct an election by mail ballot of the Directors of the Association. Said balloting must be completed and returned to the Executive Secretary no less than fifteen (15) days after direction of same.

**Section 6.** The aforesaid ballots shall conform to the following requirements: With respect to each person whose removal is sought, the question shall be submitted, "Shall \_\_\_\_ be removed from the office of \_\_\_\_ by recall?" Immediately following each such question shall be printed in the ballot the two (2) propositions in the order set forth: For the recall of (name of person), and Against the recall of (name of person). Immediately to the left of the proposition shall be placed a square in which the Director by making a cross mark (X), may vote for either of such propositions.

**Section 7.** Should a majority of votes cast at a recall election be against the removal of the officer named on the ballot, such officer shall continue in office for the remainder of his term, subject to recall as before. However, no recall petition shall be filed against an officer within ninety (90) days after such recall petition has failed to remove him. If a majority of the votes cast at a recall election be for the removal, he shall be deemed removed from office.

## **ARTICLE IX**

### **Regional Clubs**

**Section 1.** Only the APHA is empowered to use the term "Association" in its title or name with exception of those clubs who had the term in title or name prior to the adoption of this rule.

**Section 2.** All charters shall be referred to as Regional Clubs and shall be under the supervision of the APHA through the

Executive Committee and the Regional Club Committee.

**Section 3.** Constitutions, By-Laws and rules of each regional club must conform to the state laws of Incorporation and be consistent with the APHA By-Laws and rules by following standard procedures as set forth by the APHA. These standard procedures/rules may be obtained from the Regional Club Coordinator of the APHA. Regional clubs must revise/amend their By-Laws and rules as the APHA By-Laws and rules are revised/amended.

- A. Regional clubs must be formed and maintained only for the purpose of advancing and promoting the Paint Horse through the ideals of the APHA including good horsemanship and good sportsmanship.
- B. Regional club By-Laws shall include but are not limited to the following:
  - 1. Name, location, purpose and corporate seal;
  - 2. Membership, annual membership meetings and quorum;
  - 3. Board of Directors and duties of the board;
  - 4. Officers and duties of the Officers;
  - 5. Election of Directors and Officers;
  - 6. Amendments;
  - 7. Indemnification; and
  - 8. Dissolution.

**Section 4.** Any group desiring to charter a regional club should obtain an application for regional club affiliation and an information packet from the Regional Club Coordinator of the APHA that will contain step by step instructions on how to proceed with the petition of charter for regional club status. Regional clubs must have and maintain a minimum of twenty (20) members, ten (10) of whom are members in good standing of the APHA. In no case shall a club be formed that infringes on or that might create an adverse effect on an existent regional club.

- A. Applications for charters shall be reviewed by the Regional Club Committee with recommendations for approval/denial being forwarded to the Executive Committee. Final approval/denial of charter applications rest solely with the Executive Committee.
- B. No club shall receive final approval until thirty (30) days after the name and location of the proposed club has been published in the *Paint Horse Journal*.
- C. Regional club By-Laws or rules must set forth the following mandatory procedures which must be enforced. Failure to do so may result in the withholding of future show approvals.
  - 1. Hold annual election of officers and directors, the results of which must be submitted to APHA by January 1st each year and to each club member within thirty (30) days of the election.
    - a. Allow only persons with current membership in the club to vote in elections.
  - 2. Indicate date of regular scheduled annual membership meeting and set forth procedures for notification of members.
  - 3. Require treasurer to present a financial report at all meetings and prepare an annual budget and/or year-to-date financial report to all members accounting for all funds

generated by the club and special interest groups.

4. Establish rules for year-end point tabulation for year-end awards prior to the point earning period which can not be altered during or after that point earning period has been completed.
  - a. Allow point accumulation only after club dues have been paid.

**Section 5.** Once a charter is granted to a regional club, it is automatically renewed yearly provided the club continues to meet specific requirements and demonstrates a minimal level of activity.

A. Specific requirements and activity levels shall include but are not limited to the following:

1. Maintain a membership of twenty (20) members, ten (10) of whom are members of the APHA;
2. Submit a list of members and a copy of the club by-laws and the previous year's annual financial statement, which includes a listing of all income and expenditures, by May 1st of each year; and
3. Provide a minimum of two (2) club approved *or sponsored shows or trail rides*, or APHA-approved horse or *specialty shows*, per year. See Recreational Riding Guidelines on page 274.
  - a. *See fee schedule for Trail Ride Application fees, if held in lieu of an approved show.*

**Section 6.** The Regional Club Committee shall conduct five (5) year reviews of regional club by-laws, membership and activity levels at their regularly scheduled meetings in May or June and October to assure that the by-laws and rules are current, requirements and activity levels of regional clubs are being met.

**Section 7.** Failure to meet and maintain the specific requirements and minimal activity levels necessary for maintaining a regional club charter may result in the revocation of the club charter by the Executive Committee. Failure to respond to the APHA request for information/corrections within ninety (90) days of the written notice will result in requests for future horse shows being denied until said information has been received. Failure to respond to the APHA second request of information within ninety (90) days of the written request will result in the recommendation to the Executive Committee to revoke the regional club charter until said information has been received.

## **ARTICLE X** **Special Interest Clubs**

**Section 1.** Any group desiring to form a special interest club (amateur, trail, etc.) shall submit a letter stating the reason and necessity for their formation along with a set of by-laws to their parent APHA regional club for approval. These by-laws must be consistent with the APHA and the parent regional club by-laws.

**Section 2.** Special interest clubs must have and maintain a minimum of ten (10) members, five (5) of whom are members in good standing of the APHA.

**Section 3.** All special interest club members must be paid members of the parent regional club.

**Section 4.** The parent regional club shall appoint an advisor(s) or a committee to oversee the activities of the special interest club.

A. All activities of the special interest club(s) must be approved by the governing body of the parent regional club.

## **ARTICLE XI** ***AjPHA Regional Clubs***

**Section 1.** *Any group desiring to charter an AjPHA Regional Club must first make application to their APHA Regional Club as to the reason and necessity of its formation. If members of the parent regional club approves the formation, an advisor or committee shall be appointed by the parent regional club to assist the youth club. An information packet is available from the Director of Youth Activities of the APHA that contains instructions on how to proceed with the petition of charter for Regional Junior Club status.*

**Section 2.** *The group desiring to form an AjPHA Regional Club must submit their completed By-Laws and Constitution for approval to the sponsoring regional club. The sponsoring regional club is to send to the APHA Director of Youth Activities: 1) a copy of minutes of the sponsoring regional club's meeting reflecting a vote of approval of the formation of the Youth Club; 2) the Junior Club's application, signed by the sponsoring regional club's president, the Youth Club's completed By-Laws and Constitution.*

**Section 3.** *The APHA Youth Committee shall review the applications for AjPHA Regional Club charter with recommendation for approval/denial being forwarded to the AjPHA Advisory Board.*

**Section 4.** *A Regional Junior Club is eligible to be recognized and considered in good standing by the AjPHA and its Advisory Board and given the designation "regional junior club" (as approved by the AjPHA Advisory Board) when the following conditions are met:*

- A. *A minimum of ten AjPHA members.*
- B. *Youth club members must be paid up in the state or area regional club, either as a Youth or a Family members.*
- C. *The age limit for youth club membership is eighteen (18) years as set forth in Paragraph YP-010. A. in the current APHA Rule Book.*
- D. *The youth club application, the by-laws and constitution shall coincide with the AjPHA Constitution*
- E. *An advisor or committee shall be appointed by the parent regional club to assist the junior club.*
- F. *Each Regional Junior Club must send by April 1st of each year their current membership list, a current list of officers and the name(s) of the current adult advisor(s), to the APHA.*

## **ARTICLE XII** **APHA Racing Affiliates**

APHA RACING AFFILIATES, RACING AFFILIATE STATE/PROVINCIAL CLUBS. APHA may designate one club in each state/province, and when the state/province has an existing

separate racing club, APHA may designate it to represent the state/province's racing interests, as an affiliate club(s) to receive for its Members and any local or regional club affiliated with the state/provincial association/club, such benefits and assistance as APHA may, from time to time, determine, in return for the performance of duties and responsibilities to APHA as specified in the affiliation agreement of the parties. This affiliation is a privilege, not a vested right, granted or rejected at APHA's discretion on an annual basis according to procedures and requirements formulated with the advice and consent of the Executive Committee. The Racing Affiliate club shall, in no manner, have authority, express or implied, to act for, or bind, APHA in any manner.

## **ARTICLE XIII**

### **International Associations**

*Section 1. The American Paint Horse Association may from time to time, recognize two types of international associations, which have as their purpose the promotion of the American Paint Horse. The first type will be comprised of international members who desire to promote the Paint horse and be affiliated with the APHA as a regional club, but that do not register horses in an approved stud book. The second type will be comprised of international associations that do register and maintain a stud book registry, wish to be affiliated with APHA and have its horses fall under the provisions of Rule RG-021.*

*Section 2. Applications for international Regional club affiliate charter with the APHA must be submitted in the English language and follow the same guidelines as required for all other regional club applications. (See Article IX.)*

*A. Members of all recognized international regional clubs approved for charter shall remain governed by American Paint Horse Association By-laws, Rules and Regulations.*

*B. Exceptions to these required guidelines may be granted by the Executive Committee as deemed in the best interest of the APHA. See back of rule book for list of international affiliates.*

*Section 3. Application for recognized affiliation with APHA by an international association that maintains a stud book, for the purpose of promoting registered American Paint Horses, shall include a copy of that association's bylaws, rule book and stud book (all in the English language) and shall be updated annually. The APHA Executive Committee shall separately determine if the stud book will be accepted for consideration under Rule RG-021 (international appendix registry.)*

## GENERAL RULES

### GR-000. GENERAL RULES AND REGULATIONS

#### GR-005. STANDING COMMITTEES

- A. All Standing Committees shall consist of not less than three Association members in good standing. In making appointments to the committees, the President shall appoint committee members for not less than one year, and not more than three years. Future appointments to fill vacancies shall be by the President with the advice and consent of the Executive Committee.
- B. The Chairperson and Vice-Chairperson of each committee shall be appointed annually by the President and a listing of all committee members shall be published in the *Paint Horse Journal* as soon as possible after the annual meeting. The Chairperson shall only vote in case of a tie.
- C. The Standing Committees at present are:
  - Amateur Committee
  - Breed Improvement Committee
  - General Show and Contest Rules Committee
  - International Committee
  - Judges Committee
  - Racing Committee
  - Recreational Riding Committee
  - Regional Club Committee
  - Registration Committee
  - Rules Committee
  - Ways and Means Committee
  - Youth Committee
- D. Special committees may be appointed by the President from time to time to attend to special business. These committees serve for the duration of the special problem or until replaced or until the committee is disbanded.

#### GR-010. PROPOSED RULE CHANGES

- A. An APHA member, a standing committee, the Board of Directors, the Executive Committee or the APHA staff may propose a Rule Book change. A Rule Book Change is any change to the By-Laws or an addition or deletion to any other rules contained in the Rule Book. All proposed rule changes must be submitted on the form designated for this purpose and available free of charge from APHA. All blanks must be completed and a justification for the proposed change cited. Forms which are incomplete, lacking the justification, or failing to cite the specific change requested, will be returned to the originator.
  - 1. Whenever a Rule Book Change in the Rule Book is proposed, the rule with the reason and intent for the proposed

change should be directed to the APHA office with a postmark (postal meter is not acceptable) no later than January 15, so that it may be received well in advance of the annual Workshop. Regardless of postmark or lack thereof, rule changes will not be accepted if received in the APHA office later than January 20 of the calendar year.

2. All proposed Rule Book Changes, after having been thoroughly researched and reviewed by Staff, Ways and Means, Association Attorney, Executive Committee Liaisons and Executive Committee, shall then be reviewed by the Rules Committee for completeness and placed in proper and legal wording. The Rules Committee cannot change the intent of the rule as it was received from its original source. A proposed Rule Book Change that contains possible legal or financial implications, or any consequences deemed not in the best interest of the Association, may be subject to action by the Executive Committee. (A complete routing procedure and actions that may be taken concerning a proposed Rule Book Change may be obtained from the Member Services Department of the APHA.)
3. The proposed Rule Book Change, legally and properly worded, will be presented for consideration on the agenda of the appropriate standing committee at the annual Workshop.
4. A Rule Book Change cannot be voted on by the Board of Directors until it has passed in the proper standing committee. NOTE: A Rule Book Change that was defeated in the proper standing committee may be brought out of the standing committee by presenting a petition signed by twenty-five (25) eligible directors to the APHA President. This petition must be presented to the President at the same workshop the proposed Rule Book Change was defeated in the appropriate committee and before the proposed Rule Book Changes are read in the committee reports for amendment.
5. If the proposed rule change passes in the standing committee, or is brought out of committee by petition, the Chairperson will then read the proposed Rule Book Change in the committee report to the Board of Directors. The Rule Book Change is thus on the floor and subject to amendment by a member of the Board of Directors. However, any amendment must be closely related to or have bearing on the Rule Book Change. The propriety of any amendment will be decided by the Presiding Officer or Parliamentarian. If a motion for amendment is received and seconded, the amendment must be voted on at this time.
6. The proposed Rule Book Change, if amended, will be returned to the Rules Committee for review and any proper or legal wording. The Rules Committee cannot change the intent of the Rule Book Change as amended.
7. All proposed Rule Book Changes to be voted on by the Board of Directors will be published in the *Paint Horse Journal* before the Association's next Annual Convention

- or special meeting.
8. At the Association's Annual Convention or special meeting, the Board of Directors will approve or reject the recommended proposed Rule Book Change exactly as written (no further amendments). If the proposed Rule Book Change is approved, it will then be placed in the first possible issue of the *Paint Horse Journal* and will be printed in the Rule Book whenever the next scheduled printing occurs. If the proposed Rule Book Change fails to obtain approval, it can still be considered for a future Rule Book Change provided it is sent back to the Standing Committee by following all of the above procedures.
  9. If a proposed Rule Book Change is considered to be of such extreme importance by the standing committee that it must be acted upon immediately, such proposed Rule Book Change must be presented to the Executive Committee prior to any regular or special meeting of the Board of Directors and is subject to amendments. If amended, the amendments must be approved or disapproved. The Emergency Status of the proposed Rule Book Change should then be put to a vote by the Board of Directors. If the Board of Directors approved the Emergency Status, the proposed Rule Book Change with any amendments attached shall then be put to a vote by the Board of Directors for immediate action. If approved, the Rule Book Change can become effective immediately. If the Emergency Status of the proposed Rule Book Change is rejected by the Board of Directors, the proposed Rule Book Change itself cannot be put to a vote at this time but can still be presented for a vote by normal procedure at the Annual Convention or Special Meeting.
  10. A new or amended rule or regulation may be considered for change, addition or repeal, one calendar year after the proposed rule takes effect, which limitation may be waived by the Executive Committee upon finding an extraordinary circumstance which 1) concerns the safety, health or well being of a horse and/or rider; 2) materially benefits the Association's programs or its financial stability; or 3) involves other compelling circumstances.

#### **GR-020. MEMBERSHIP**

- A. Membership shall consist of three categories: Annual, Multi-Year and Life memberships. Membership shall not be limited to natural persons, but may include corporations and partnerships. Proper receipts and membership cards shall be issued upon payment of fees.
- B. The application for membership should indicate clearly the name in which the memberships to be recorded. Any registrations or transfers submitted utilizing the membership shall be recorded in the same exact name as that appearing on the membership, or a non-member fee will be charged. In no case shall the membership name exceed 30 characters (letters and spaces). Members shall be admitted to the Association on a written application accompanied by the current membership

fee. Membership may be terminated or rejected by the Executive Committee or Board of Directors for cause detrimental to the interests of the Association. By applying for membership, the applicant automatically agrees to be bound by and to abide by all rules, regulations and policies of the Association.

- C. Termination or application rejection proceedings shall be conducted under the Association's disciplinary procedure for notice, hearing and temporary suspension. The effect of termination or rejection may be denial of the privileges of the Association as set forth in the Association's disciplinary procedure.
- D. The name of a member may be changed in the membership records of the Association to reflect a change of name. Such a change shall be made upon submission of documentation (e.g. marriage license, court decree, etc.) reflecting a change of name by said member. Member shall also submit the original certificate of registration, a transfer report, signed as seller, showing member's previous name in the space provided for seller, the new name in space provided for buyer and the \$2.50 correction fee. A current membership in the new name is required.
- E. General privileges and responsibilities of members and non-members are as follows:
  - 1. All members, while in good standing, shall have equal rights, interests and responsibilities with respect to the Association and its property; shall obey and be bound by all By-Laws, Rules and Regulations of the Association and decisions or actions of the Board of Directors or Executive Committee; shall have the right to vote in the National Director Election if a regular or life member as of February 1 the year the election is conducted; shall have the right to vote by personal attendance at membership meetings and shall have the right to hold office and committee assignments, except as otherwise limited.
  - 2. In regard to individuals who are non-members, but own American Paint Horses, file registration applications and other documents with the Association, or participate in Association-approved events, by such actions and in regard to such transactions, do thereby agree to be bound by all By-Laws, Rules and Regulations of the Association and decisions and actions of the Board of Directors or Executive Committee.
  - 3. All members and individuals who are non-members, but own American Paint Horses, file registration applications and other documents with the Association, or participate in Association-approved events, by such actions, and in regard to such transactions, do thereby agree that as a part of their relationship with the American Paint Horse Association, said members and non-members are obligated to submit to any and all APHA-approved Ranch Inspections, and to assist and cooperate fully with all APHA employees and/or designated representatives with regard to said inspection. Ranch Inspections shall include,

but not be limited to, a visual inspection of all horses listed with the Association as being owned by the member or non-member. The Association is under no obligation to advise members or non-members of a pending Ranch Inspection. Every member, and non-member, shall cooperate fully with the APHA and its representatives in connection with any ranch inspection or related procedures. Refusal to cooperate, or delays in providing assistance, may be construed as a violation of this Rule and subjects the member, or non-member, to disciplinary action.

F. A membership fee is not refundable.

### **Types of Membership**

G. **ANNUAL MEMBERSHIP.** An annual membership consists of a 12-month period beginning with the month of purchase (based on postmark, postal meters not acceptable), and expiring the last day of the subsequent 12th month. (Example: if membership is postmarked Feb. 20, it expires Jan. 31 of the following year.) An annual fee of twenty-five dollars (\$25) shall be paid for each (12-month) annual membership. Renewal notice to the members shall be sent to their last known address not less than thirty (30) days prior to the end of the 12th month. When an annual membership expires, the membership can be reinstated by simply paying the current year's annual fee.

1. Any member whose membership becomes delinquent can be reinstated by paying the current year's dues. There is no penalty for reinstatement.
2. Regular memberships may be paid in advance in three to five year increments based on the annual membership period. See fee schedule in front of Rule Book.
3. A membership does not include a subscription to the *Paint Horse Journal*.

H. **LIFE MEMBERSHIP.** A fee of \$300.00 is required for life-time membership, but no annual fees are required. A life membership purchased after the above date is entitled to receive a life membership pin, certificate, and to register or transfer horses, purchase an annual *Paint Horse Journal* subscription, or obtain any other APHA services at the member rate. Life memberships may only be issued to individuals (life memberships cannot be listed to ranch or corporation entities). See GR-020.H.1. regarding transfer of life membership.

1. A life membership is not transferable, but a life membership may be carried in the joint names of husband and wife. If so carried, the name on the membership may be changed by one-time amendment, and the successor of them (spouse's death or divorce) shall be entitled to exclusive life membership to correctly reflect the successor's status. Such request should be accompanied by filing with the Association a copy of judicial decree, written evidence of death, or written instrument of consent signed by the terminating spouse. (Once amended, the membership cannot be altered under the single name amendment procedure below.)
2. If the life membership is carried in a single person's name,

the name of a later spouse may be added by one-time amendment. A life membership amended from the singular to the joint may be amended back to the original life member's name.

3. Life memberships may be purchased on the installment plan upon payment of \$100.00 down, with payment period not to exceed 12 months. Any life membership for which payment has not been completed within the specified time frame shall forfeit all fees paid to date.
4. The president shall receive a lifetime membership and shall receive all benefits of such membership.
- I. **AjPHA MEMBERSHIP:** The annual dues for members of the American Junior Paint Horse Association are \$12.50 each. Junior membership is available to unmarried youths eighteen (18) years of age or younger. AjPHA membership must be purchased under one individual's name. An AjPHA membership is based on a 12-month period beginning with the month of purchase and expiring the last day of the subsequent 12th month (Example: if membership is postmarked Feb. 20, it expires Jan. 31 of the following year) and does not include a subscription to the *Paint Horse Journal*. AjPHA membership does not include voting privileges in the APHA except as pertains to Youth matters. An AjPHA member may register horses in his/her name at member rates for the full term of said membership.
- J. **AjPHA J-Term Membership (through age 18).** Allows youth 18 years of age or under as of January 1, the privilege of membership in the AjPHA. The AjPHA J-Term member (through age 18) will receive a momento, J-Term membership certificate and the AjPHA newsletter. See fee schedule, Rule YP-005 and YP-010.
- K. **Multi-Year Membership.** A multi-year membership consists of a 36-month period beginning with the month of purchase and expiring the last day of the subsequent 36th month, or a 60-month period beginning with the month of purchase and expiring the last day of the subsequent 60th month. (See fee schedule at front of book for 3-year and 5-year fees.)
- L. A subscription to the *Paint Horse Journal* may be obtained by remitting an additional fee (see fee schedule).
- M. In order for a Paint horse to receive an APHA award, the owner must be an APHA member on the date the award is bestowed. To be eligible to receive the award, the owner may retroactively purchase the required annual membership. Despite owner eligibility, the horse's achievement will be recorded in its permanent record.

### **GR-030. TELEVISION AND MEDIA RULE**

- A. Attendance at an APHA-approved event, in whatever capacity, shall constitute authorization for APHA, its agents, designees, or assigns to photograph, video tape, televise, or record by other means (hereinafter referred to as "photographic material") any person or animal on the premises of an APHA-approved event, and shall further constitute authorization for the use of such person's name, voice and biography, or the

name, pedigree and performance record of any animal on the premises (hereinafter referred to as “related information”) in conjunction with any photographic material.

- B. The photographic material and related information referred to above may be used in any manner that the APHA, in its sole discretion, determines would be beneficial to promoting the purposes and goals of the APHA; provided, however, that no photographic material or related information will be used in conjunction with the endorsement of any product unless prior written consent is obtained.
- C. Attendance at an APHA-approved event shall further constitute agreement to the terms and conditions outlined above, and shall constitute a waiver and release, without limitation, of any individual television, radio, motion picture, photographic or other similar rights, including right of privacy, any person or animal may have in or to such photographic material or related information when such information is obtained at an APHA-approved event by the APHA, its agents, designees, or assigns.
- D. An APHA member, including a member using APHA data for commercial purposes, has a duty to preserve and protect the pedigree registry/performance records and the property of APHA, including, but not limited to, APHA electronic data made available to members via the APHA Web site or other prearranged consensual access thereto, and the duty to use such data only for the purposes which APHA has granted conditional license. Publication of such data shall carry the following designation: “This information was provided by the American Paint Horse Association from its Official Records.”

#### **GR-040. RESPONSIBILITY**

- A. The American Paint Horse Association will not assume the responsibility of settling civil disputes concerning financial settlements, ownership, health or fertility.
- B. No person shall refuse the reasonable request to assist the Association, its officers, committees or agents in locating, identifying and inspecting or to answer promptly and truthfully any inquiry concerning an animal or ancestor thereof in his ownership or control, which has been registered or listed, for which application to register or list has been made, or to sign requested documentation. A violation of this rule may be grounds for disciplinary action.
- C. In the furtherance of their official duties, all Association representatives shall be treated with courtesy, cooperation and respect and no person shall direct abusive or threatening conduct toward them.
- D. All information furnished the Association as a basis for any action by the Association or any of its officers shall be true and correct. This includes, but is not limited to, registration applications, application for show or race approval, and all information in regard to Association investigation of third parties.
- E. Accuracy of records furnished by the Association, either as hard copy or on-line service, is warranted by the APHA only to the extent of using its best efforts in the compilation thereof

and then solely for the benefit of the member or party purchasing the record. Reimbursement of the expense of the record on a showing of material inaccuracy is the sole remedy available to anyone receiving inaccurate information from the Association. Consequential damages are expressly excluded. No warranties, express or implied, arise from records issuance, other than as stated therein, as the purchaser receives this record on an "as is" basis. For absolute accuracy, independent verification must be obtained from the current owner or his predecessor in title to the subject horse.

- F. In all proceedings concerned with or affecting the registrations and records of the Association and in all disciplinary actions, the burden of resolving any doubt as to the true parentage or identification of an animal, or qualification for registration (either by color, type or bloodline) shall be upon the applicant, owner, lessee or other member(s) or non-member(s) involved. The determination, decision or action of the Executive Committee upon all such questions shall be final and binding upon all parties. As the owner has the burden of proof, by failure to present evidence concerning such questions to the Association or at a hearing scheduled to resolve the question, the owner shall be deemed to have waived his right to later present such evidence to a court of law, if he seeks judicial review of the Association's action.
- G. When an exhibitor, owner or trainer is guilty of unsportsmanlike conduct, such person is subject to disciplinary action by the APHA, including but not limited to, fines or suspension.

#### **GR-045. LIABILITY**

- A. The APHA, its officers, directors, members of committees, inspectors, employees, representatives, and agents will attempt to obtain true and complete information in connection with registration of Paint Horses, transfer of registration certificates, hearing, and all other matters relating to APHA activities. Except for proven intentional wrongdoing, neither the APHA nor its officers, directors, members of committees, inspectors, employees, representatives nor agents will be liable in any way, whether in damages or otherwise, for issuance of any pedigree certificate, for the transfer of any pedigree certificate, for the cancellation of any pedigree certificate, for the refusal to issue a pedigree certificate, for the issuance of any pedigree statements, for the refusal to transfer any pedigree certificate, for any disciplinary procedure brought against or penalties imposed on any member or any person or for any other activities engaged in, by or on behalf of the American Paint Horse Association.

#### **GR-050. RELEASE OF LIABILITY**

- A. The APHA and co-sponsoring organizations, if any, shall not be responsible for any personal injury, or for loss or damage to property, occurring at any APHA activity. Each owner, exhibitor, handler, or consignor shall indemnify and hold harm-

less the APHA, its officers, directors and employees from and against all claims, demands, causes of actions, and expenses of every kind, including attorney's fees, arising out of or related in any manner to the acts or omissions of an owner, exhibitor, handler, or consignor, or the actions of any animal under the care, custody, or control of the owner, exhibitor, handler or consignor. Presentation of signed entry or consignment forms shall be deemed acceptance of the conditions of this rule. In the event an entry or consignment form is not signed or presented, appearance on the grounds or at the sale ring of any APHA activity as an exhibitor, handler, owner, or consignor shall be deemed to be acceptance of the conditions of this rule.

**B. *Disclaimer of Responsibility for Safety of Show or Event Participants:***

- 1. Show/event management is responsible for the condition of show/event premises, including arena and exercise areas; the conduct and competence of show/event employees and other representatives; implementation of show activities and events; and all other aspects of an APHA-approved show/ event.*
- 2. APHA does not assume or accept duty or responsibility for safety at this show/event in regard to participants or any other third parties, or for the horses or other property thereof.*
- 3. As an express condition of the privilege to participate at an APHA-approved or sponsored show or event, each owner of an American Paint Horse, exhibitor, trainer, participants, assume the risks of participation, and release and discharge APHA, its officers, directors, representatives, and employees, from any and all liability, whenever or however arising, as to personal injury or property damage, occurring as a result of participation in a show/event conducted by the show/event or on the show/event grounds thereof.*
- 4. Without assuming the affirmative duty to monitor possible physical or mental handicaps of exhibitors, if condition of exhibitors' physical or mental disability comes to the attention of APHA, the individual may be denied participation privileges in APHA-approved events until such time as he or she provides APHA with sufficient information to conclusively establish physical or mental capability to participate, without posing a significant risk to the health or safety of the individual and/or the other exhibitors of the class in which he or she desires to participate. At APHA's sole discretion, the individual may be authorized to use special equipment to enhance physical ability to safely exhibit in APHA-approved or sponsored shows/ events. (See Rule SC-160.F.)*

**GR-055. APHA FUNDS**

- A. Any and all fees or monies due the APHA are the property of the APHA upon collection and shall be turned over to the Association within thirty (30) days of collection. The officers of such club and/or individuals responsible for the collection

and disbursement of such funds shall be personally liable and, in addition, subject to the rules pertaining to violations and disciplinary procedures.

- B. Any and all fees or monies due APHA must be paid in U.S. Funds only.

### **GR-060. VIOLATIONS**

- A. Any member may be suspended and denied privileges of the Association, and any non-member may be denied the privileges of the Association by the Executive Secretary of the Association, for the failure to pay when due any obligation owing the Association. This includes but is not limited to the *Paint Horse Journal*, or to an approved show, or for giving a worthless check for entry fees, stall fees, office charges, stock charges or any other fees or charges including bank charges for returned checks connected with the exhibition of horses; or for failure to timely file with the Association required annual stallion breeding reports, genetic testing by DNA, stallion listing cards or any related fees. Fifteen (15) days before action by the Executive Secretary, written notice of the account due or delinquent stallion breeding report and the intention to suspend or withhold privileges of the Association shall be mailed to such member or non-member. Upon suspension by the Executive Secretary, the name of the member or non-member may be published in the *Paint Horse Journal* beginning with the next available issue from date of suspension. Any suspension and denial of privileges of the Association under this section shall terminate upon full payment of the obligations due the Association or upon filing of the requisite stallion breeding report, listing card and/or filing, listing or late fees due. (GR-070 A.-P. of the disciplinary procedures shall apply.)
- B. If it is determined by a court of law that any officer, director, member or appointed official of an approved APHA regional club has misappropriated funds of the club in any manner, that person may be suspended, fined, or denied all privileges of the association.
- C. When any person is guilty of the following: failure to pay when due any obligation owing to the Association; giving a worthless check or otherwise failing to pay for entry fees, stall fees, office charges connected with the exhibition of horses, such person, whether member or non-member, will be subject to disciplinary procedures insofar as practical.
- D. If a member or non-member fraudulently claims or advertises an APHA title, award or points prior to the title, award or points being officially awarded or recorded by APHA, or uses a title other than the official title of the award as specified by APHA rules, the registration certificate may be revoked permanently and the owner of record may be subject to disciplinary action.
- E. Every member and every non-member who violates in any manner the Constitution, By-Laws or Rules and Regulations of the Association; whose practices in the breeding of Paint Horses or in supplying information for the Association's

records; or whose conduct has endangered or may endanger the good order, welfare or credit of the Association; or who is convicted in a court of law for cruelty to animals and upon submission of certified evidence of such conviction from any court, may be censured, suspended or, in the case of a member, expelled from membership in the Association and denied all privileges of the Association, including, without limitation of the generality of the foregoing, the privilege of registrations or change in ownership of Paint Horses on the records of the Association by the Executive Committee.

- F. Ownership of an issued registration certificate remains with the Association. Such registration certificate is issued in reliance upon the information provided on the written application submitted and attested by the owner at the time of foaling; and upon the express condition that the Association has the privilege to correct and/or cancel the certificate for cause under its rules and regulations. No person shall refuse an Association request for the return of a registration certificate, either before, after or pending hearing to determine registration participation privilege in Association-approved events. The Association may retain possession of a certificate pending resolution of the matter for which the return of the certificate was requested. (See Rule RG-140.C.)
- G. An owner or lessee may be subject to disciplinary action if his/her horse and third party, i.e. trainer/exhibitor, is found guilty of a repeat offense.

#### **GR-065. FRAUDULENT PRACTICES**

- A. No person shall represent any animal owned or managed by him to be registered unless the same be registered in the official stud book.
- B. No person, firm or corporation shall issue, sell, exchange, give away or receive, or offer to do any thereof, any false or fraudulent certificate representing same to be a genuine official certificate issued by the Association.
- C. No person shall advertise, or enter in any Paint horse event or competition any animal registered or listed with the Association by a name other than that by which it is registered or listed.
- D. No change in or alteration of a certificate of registration or listing or identification required by the Association shall be made except by the Association or its official representative upon proper showing of the necessity for such change or alteration by reason of change in color or markings, mistake or the like; nor shall any person display or advertise or have in his possession any such certificate, including but not limited to the original certificate issued, a duplicate certificate issued, a photocopy, a scanned copy or image that has been changed or altered otherwise, other than by the Association or on its authority.
- E. No person shall alter in any way, change or attempt to hide or alter the natural markings of a horse, by surgery, dye or in any other manner.
- F. No person shall represent as a registered American Paint Horse

any horse other than the horse for which said certificate was issued.

- G. No person shall bribe, or attempt to bribe, an APHA representative, APHA-approved judge, or any other official of an APHA-approved event.
- H. *Conduct prohibited as described in GR-066.*

#### **GR-066. UNSPORTSMANLIKE CONDUCT**

- A. *Conduct by APHA members, non-members, exhibitors, trainers, owners, owner's representatives, spectators, and all other persons present on the show grounds or in show facilities, events where the APHA has approved or sponsored the event, the event is held in conjunction with an APHA-approved event or APHA has sponsored added money or awards, shall be orderly, responsible, sportsmanlike and humane in the treatment of horses, such as to promote the implementation of the show or event and promote fair competition.*
  - 1. *Unsportsmanlike or irresponsible conduct or any other form of misconduct, that is illegal, indecent, profane, intimidating, threatening, harassing, or abusive is prohibited, as is the inhumane treatment of horses.*
  - 2. *Further, Show Management may immediately expel offenders from show grounds or show facilities in order to preserve the decorum of the show and shall file a written report with APHA concerning the transaction.*

#### **GR-070. DISCIPLINARY PROCEDURE**

- A. Any member may be disciplined, suspended, fined or expelled from the Association, and any member or non-member may be denied any and all privileges of the Association, or any registration certificate may be canceled whenever it shall have been established by satisfactory evidence that such member or non-member has violated any By-law, rule, or regulation of the Association.
- B. The Executive Secretary, his staff, and designees shall have sole authority to investigate possible or alleged violations of any by-law, rule, or regulation of the Association.
  - 1. In order for a complaint, other than one which can be verified by credible testing, to be considered for investigation, it must be in writing, signed and dated. The individual(s) filing the complaint must be prepared for full disclosure of the complaint to the party (parties) concerned in the complaint and must be prepared to appear at a hearing if it is deemed necessary.
- C. When it is determined that there is sufficient cause for a hearing, the person charged with any alleged violation shall be given not less than twenty-one (21) days' notice of a time and place for hearing such allegations by the Executive Committee, at which time and place he shall have the opportunity, in person or by counsel, to be heard and to present evidence in his own behalf, and to hear and receive evidence offered against him.

1. The Executive Secretary shall have the authority to schedule a disciplinary hearing when he determines there is sufficient cause for a hearing. Additionally, a disciplinary hearing shall be held if it is requested by two members of the Executive Committee or by the President.
  2. Four members of the Executive Committee shall constitute a quorum for purposes of disciplinary hearing.
  3. Testimony may be taken at a hearing via telephone. Any person desiring to present testimony via telephone should notify all involved persons in writing, at least five (5) days prior to the scheduled hearing. This notice should contain the name, address and telephone number of each person who will testify via telephone. This provision is not intended to limit or preclude other appropriate procedures for offering testimony or evidence at hearings.
  4. No continuance shall be granted unless requested in writing at least seven (7) days prior to the hearing, and good cause is shown. A continuance shall be granted or denied at the sole discretion of the President.
  5. The decision and action of the Executive Committee shall be final and binding on all parties.
- D. **In regard to any violation of Show and Contest Rules**, as a part of its disciplinary action, the Executive Committee may revoke participation privileges in all APHA-approved events for determined or indefinite period, assess a fine (**see E. and F. below**); and may deny access to presence on show grounds.
- E. Pending final hearing by the Executive Committee or such other appropriate committee, the Executive Secretary may, by giving written notice of his action:
1. Temporarily suspend such member, the effect of which shall be to deny him further Association privileges until the Executive Committee can hear the matter and take the appropriate disciplinary action; and
  2. Temporarily suspend the registration of the horse in question, and upon Association request, the owner shall return the registration certificate to the Executive Secretary, pending final determination of its validity, the effect of which shall be to suspend participation privileges in Association-approved events.
- F. On or after such time as any person has been denied participation privileges in APHA-approved events, but that his membership privileges are not effected, the following restrictions shall apply:
1. That person shall not be eligible to participate in any APHA-approved event or in events where APHA has sponsorship of added money or awards are given.
  2. That person shall not be eligible to hold approved judges credentials or any other Association accreditation:
  3. Horses which are recorded in the name of such person or owned in whole or in part by such person, are not eligible to participate in any APHA-approved event:
  4. During the period of denial of Association privileges failure to comply with these restrictions and any other express conditions or restrictions of said disciplinary actions may

constitute grounds for further disciplinary action.

- G. When a member is disciplined, suspended, expelled or fined, or a non-member is denied membership privileges, or when a member or non-member is temporarily suspended by the Executive Secretary, pending hearing, the name and address of such member or non-member may be published in the *Paint Horse Journal*.
- H. See SC-085.L. for additional provisions.
- I. PROBATION.
  - 1. Probation means that a person's conduct and actions with respect to all APHA activities are subject to strict review during the period of probation. A person who violates an APHA by-law, rule or regulation while on probation is subject to more severe disciplinary action than might otherwise be the case.
  - 2. A person on probation is not a member in good standing with the APHA, and may not serve as an officer or director of the APHA while on probation.
- J. In the event any disciplinary action is taken against a member or non-member, publication of the action shall be made as soon as practical in the *Paint Horse Journal*. Said publication shall include rule number violated for disciplinary action to have been assessed.
- K. **On or after such time as any person has been suspended, expelled or denied further Association privileges, in addition to other provisions of this handbook or policy of the Association, the following restrictions shall apply:**
  - 1. **That person shall not participate, and shall be ineligible to participate, in any APHA-approved event. Nor shall such person be eligible to hold approved judge's credentials or any other Association accreditation.**
  - 2. **That person or spouse shall not register or lease any horse with the Association, or transfer registered horses into his or her name or that of a spouse or minor child under the age of eighteen (18) living in the same household.**
  - 3. **No checks, money orders, cash or credit cards of any kind will be accepted from the suspended individual, spouse or minor child under the age of eighteen (18) living in the same household, for Association transactions during the period of suspension. Exception: Any form of payment may be accepted for the purpose of paying fines or fees associated with removal from suspension or transferring horses out of the suspended party's ownership unless that party is on a collected funds status.**
  - 4. **No horse shall be registered which is either sired by a stallion or out of a mare owned by such person or spouse where the breeding date is shown to be on or subsequent to the date of disciplinary action; provided, however, when a suspension arises out of the failure to pay any financial obligation owing to the Association, or the failure to file a stallion breeding report, the Executive Committee may approve the registration**

- requests upon the payment of all money due and owing the Association or filing all the delinquent stallion breeding reports, together with any additional fee that may be required for such registrations. Additionally, the Executive Committee may permit the registration of horses resulting from breedings occurring during a period of suspension when it determines that a third party will be unjustly penalized if such registration is not permitted.
5. No horse which is registered in the name of such person or spouse is eligible to participate in any event approved or recognized by the Association, such as shows or races.
  6. Signatures:
    - a. The Association shall not accept the signature of such person, nor such person's spouse, nor that of such person's children under the age of eighteen (18), living in the same household, on any breeder's certificates, or stallion breeding reports, evidencing breeding taking place on or after the date of suspension.
    - b. The signatures of the suspended person and that person's spouse will be honored on transfer reports for the purpose of allowing such disciplined person or spouse to transfer horses recorded in his or her ownership at the time of the disciplinary action.
  7. Advertising:
    - a. No person on suspension, or any non-member who has been denied privileges, nor that person's spouse, may advertise in the Paint Horse Journal during the period of his suspension, nor may that person's name, logo or ranch name, nor that of his spouse, or such persons' children under the age of eighteen (18) living in the same household, appear in any advertisements or print media, regardless of person placing the advertisement, in the Paint Horse Journal during the period of suspension.
    - b. If publication deadlines or other factors make it impractical to stop advertising that is in violation of Rule GR-070.K.6.a. this advertising will be terminated as soon as possible.
  8. If the disciplinary action taken against a member, or non-member, includes denial of access or presence on show grounds, the member, or non-member, shall refrain from entry or presence on show grounds during any APHA-approved show during the term of suspension.
  - L. During the period of expulsion, suspension or denial of Association privileges, failure to comply with these restrictions and any other express conditions or restrictions of said disciplinary action may constitute grounds for further disciplinary action.
  - M. Written leases filed with the APHA office, prior to date of suspension, covering horses owned by the suspended mem-

ber shall be valid, and the signature of the lessee shall be accepted during the time of such lease but for no renewal thereof. Suspended members may not record leases into or out of their ownership while membership privileges are denied.

- N. The provision of the disciplinary rules which pertains to notice and hearing procedure shall also apply to hearings regarding registration issues and other non-disciplinary matters.
- O. The Association has adopted the following provision for the mutual benefit of members and with the intention of reducing the Association's litigation expenses, which expenses would ultimately be borne by members and non-members participating in Association activities. Every member, by joining the Association, or non-member, by purchasing American Paint Horses, filing a registration application or other documents with the Association, or participating in Association-approved events, does thereby agree as follows:
  - 1. If unsuccessful in an attempt to overturn Association decisions, actions, rules or regulations, to reimburse the Association for its reasonable attorney's fees, court costs and other expenses in defense of such suit; and,
  - 2. That he will not commence any action, whether in law or equity, against the Association in any courts other than those federal and state courts located in Tarrant County, Texas.

**General Notice Procedure:**

- P. Notice required by these rules and regulations may be served by delivering a copy of the notice to the person to be served, or his attorney, either in person or by mail, postage prepaid, to his last known address as it appears on the Association's records, and upon mailing, such notice shall be deemed received by such person when it is deposited in the United States mail.

**GR-071. FACSIMILE TRANSMISSIONS (FAX)**

- A. APHA's staff is authorized, but not required, to accept a facsimile transmission "fax" of an original document, when in the opinion of the staff representative, the sender is (1) the authorized party executing the document, or (2) a party having substantial interest in the subject horse, has obtained the original document from the authorized person, and so verifies the genuineness of the document in the sender's possession to the satisfaction of the staff representative.

## REGISTRATION

### RG-000. RULES AND REGULATIONS OF REGISTRATION

The following Rules and Regulations shall become effective January 1, of the current year, and thereupon all Rules and Regulations and parts thereof, heretofore in force, are hereby repealed.

### SPECIAL NOTICE APPLICANTS ARE RESPONSIBLE FOR KNOWLEDGE OF ALL REGISTRATION RULES AND REGULATIONS

#### RG-010. THE STUD BOOK

- A. On June 3, 1965, the American Paint Stock Horse Association and the American Paint Quarter Horse Association consolidated to form the AMERICAN PAINT HORSE ASSOCIATION.
- B. All animals registered in the APSHA & APQHA registry shall retain their respective names and numbers as shown therein and shall be henceforth recognized in the official APHA Stud Book.
- C. The official Stud Book of the Association shall consist of two parts: (1) numbered and (2) appendix.

#### RG-015. BLOODLINE REQUIREMENT

- A. Deceased horses are ineligible for registration.
- B. As of January 1, 1980, all horses for which applications of registration are submitted must have both sire and dam registered in the APHA, APQHA, APSHA, the American Quarter Horse Association, the Jockey Club or any foreign Thoroughbred Registry recognized by the Jockey Club or the combination of any two of these associations. (See Rule RG-035. B. for AQHA and Thoroughbred stallion listing requirements.) A breeder's certificate must be furnished. (See RG-045. for details and exceptions.) Any horses showing the characteristics or distinguishing qualities of any other breed are subject to removal from or rejection of registration in this Association.
- C. *AQHA Appendix and AQHA numbered stallions and mares shall have the same status for registration of Paint foals. Applications for the registration of horses out of Thoroughbred, AQHA numbered and AQHA Appendix mares must be accompanied by a photostatic copy of the dam's registration certificate (both front and back) for verification of bloodlines and ownership. (See Rule RG-070.C.4.)*

## RG-020. THE REGISTRIES

### A. REGULAR REGISTRY.

1. All horses in the Regular Registry will be identified by a permanent registration number. The Regular Registry shall include:
  - a. All Paint stallions, mares and geldings which meet the requirements of Rule RG-015. and the color requirements of Rule RG-110. A-G.
  - b. All Paint stallions, mares and geldings over two years of age or older which have met the advancement requirements of Rule RG-060.F. 1989 Rule Book and the color requirements of Rule RG-110. A- G.
  - c. All horses resulting from the breeding of two Quarter Horses or a Quarter Horse and a Thoroughbred or two Thoroughbreds must be parentage verified using DNA genetic testing prior to registration in the Regular Registry.

### B. BREEDING STOCK REGISTRY.

1. Breeding Stock Registry is provided to record the pedigree of stallions and mares that are ineligible for registration in the American Quarter Horse Association, the Jockey Club or any foreign Thoroughbred registry recognized by the Jockey Club, or the Regular or Appendix Registry of the APHA. Horses in the Breeding Stock Registry will be limited to mares and stallions. Geldings are not eligible except as provided in Rule RG-020. C. 1. The following horses will be listed in the regular Stud Book of the Association.
  - a. Resultant solid color foals from two registered Paint Horses.
  - b. Resultant solid color foals from a Paint Horse registered in the American Paint Horse Association and a Quarter Horse registered in the American Quarter Horse Association or a Thoroughbred registered in the Jockey Club or any foreign Thoroughbred Registry recognized by the Jockey Club.
  - c. All horses resulting from the breeding of two Quarter Horses or a Quarter Horse and a Thoroughbred or two Thoroughbreds that are ineligible for registration with their respective breed registry.
    1. Horses without a Paint parent must be parentage verified using DNA genetic testing prior to registration in the Breeding Stock Registry.
    2. If a horse without a Paint parent is registered in the Breeding Stock registry and later registered with their respective breed association, the APHA registration will be subject to cancellation and the certificate of registration will be null and void.
2. Horses registered in the Breeding Stock Registry are restricted from competition with Regular Registry horses and do not have the same privileges as horses registered in the Regular Registry. See Rules SC-165. and RA-000.D. for restrictions.
3. Appendix and hardship horses may be advanced by meet-

ing the requirements of Rule RG-060. F. 1989 Rule Book upon reaching two years of age.

**C. Identification Status.**

1. Solid colored geldings previously registered as stallions or solid colored geldings with at least one registered Paint parent will be accepted for identification status upon the surrender of the certificate of registration and written notice of date of castration.

**RG-021. APPENDIX REGISTRATION OF INTERNATIONAL REGISTERED HORSES**

**A. DEFINITION OF INTERNATIONAL APPENDIX REGISTRATION.** *International* Appendix registration is provided to horses registered with a Paint Horse Association located in a *international* country that is recognized by the American Paint Horse Association (hereinafter referred to as a *International* Registry or (*IR*)). Recognition may be granted to international Paint Horse Associations which operate their own stud book, are consistent with bloodlines and breed restrictions as adopted by the American Paint Horse Association (APHA), and whose registry maintains accurate and appropriate documentation and records. Recognition is at the discretion of APHA.

1. *International* Appendix Registration indicates an intent to use a stallion or mare in a breeding program *designed to produce offspring eligible for registration with full APHA privileges. Registration of a gelding in the appendix registry would be for performance purposes only.* The horse's owner must make application and obtain a registration certificate through the *IR* in the country in which he resides and supply the APHA with a copy of the completed certificate and all required proof of breeding and identification. Applications received without prior registration in the respective *international* association will not be approved for issuance of a *International* Appendix certificate until such evidence is received.

**B. INTERNATIONAL APPENDIX DESIGNATION.** Horses registered in the *International* Appendix registry are granted the appropriate level of appendix designation based upon APHA *approved bloodlines* within their pedigree. All horses registered with a *IR* will be eligible for a minimum of 50% APHA *International* Appendix registration (hereinafter referred to as F1). Higher levels may be granted based upon pedigree.

**C. PROCEDURES AND FORMS FOR INTERNATIONAL APPENDIX REGISTRATION.** To apply for *International* Appendix Registration, the following requirements must be met:

1. The *horse* must be registered with an *IR* that has been approved by APHA. The horse must have been issued a registration certificate by such *IR*, and the bloodlines of the horse must trace back in all lines to approved bloodlines and breeds.
2. An application for *International* Appendix Registration

- must be completed and signed by the recorded owner (as recorded in the official records of the *IR*). Forms are available from the APHA office.
3. A photocopy, front and back, of the *IR* registration certificate must be provided.
  4. Current photographs of the horse applying for *International Appendix Registration* must be submitted. The photographs must include a left sideview, right sideview, front and rear.
  5. Remittance of the *International Appendix Registration* fee (see fee schedule at the front of the book) .
  6. Upon completion of processing, the recorded owner will receive an *International Appendix* certificate issued by APHA. Such certificate will be issued to certify that the horse has completed international appendix registration requirements. *International Appendix* registered horses are not eligible to compete in APHA approved events or *shows* (unless specifically intended for *International Appendix* registered horses) and can only be advertised as '*APHA Appendix* registered'.
- D. **CHANGES IN OWNERSHIP.** If a horse has been previously *International Appendix* registered and ownership changes, the new owner must submit a photocopy of the certificate showing that the ownership update has been properly recorded in the *IR*. Upon receipt of the photocopy of the *IR* registration certificate and a recording fee (see fee schedule at the front of the rule book), APHA will update ownership accordingly.
- E. **APPENDIX DESIGNATION OF PRODUCE/GET OF AN INTERNATIONAL APPENDIX REGISTERED HORSE.**
1. When an F1 stallion/mare is bred to an APHA registered/*recognized* sire/dam, the resulting foal is eligible for *International Appendix Registration* as an F2 (75% APHA Appendix Registered horse).
  2. When an F2 horse is bred to an APHA registered/*recognized* sire/dam, a resulting foal from that breeding is eligible for *International Appendix Registration* as an F3 (87.5% APHA Appendix Registered horse).
    - a. If the resulting foal from an F2/APHA *registered/recognized* sire/dam is a filly, the F3 filly would be considered eligible for APHA double registration providing all privileges of APHA full registration.
    - b. If the resulting foal is a colt, the colt would be granted F3 *International Appendix* registration. This colt will remain a F3 horse and is not eligible to receive APHA double registration.
      1. If an F3 colt is bred to an APHA registered/*recognized* dam, the resulting F4 foal from that breeding would be considered as eligible for APHA double registration providing all privileges of APHA full registration, regardless of sex.
- F. **FULL APHA REGISTRATION.** Eligibility to *apply* for full APHA registration is provided to a filly upon reaching F3 or a colt *resulting from a breeding as described in F4*. Full registration provides all privileges of APHA registration.

- G. PROCEDURES FOR FULL APHA REGISTRATION.** To register your foal for full APHA registration status, the following items must be submitted in their entirety:
1. Foal Information
    - a. Complete an American Paint Horse Association registration application. Information should be consistent with the horse's *IR* registration certificate.
    - b. The name issued at the *IR* should be listed as the first name choice.
      1. List a second and third choice in the event that the first name choice is not available.
    - c. A photocopy, both front and back, of the foal's *IR* registration showing complete ownership record and markings must be submitted.
  2. Stallion Requirements
    - a. Breeder's Certificate/ SBR. The copy of the foal's *IR* registration certificate will be used in lieu of a Breeder's Certificate and/or Stallion Breeding Report. When completing the Breeder's Certificate, you need only to list the names of the sire and dam. Stallion Breeding Report information will be obtained directly from *IR*, but the appropriate filing fees will still apply. (See fee schedule in the front of the rule book for current filing fees.) If the sire already has a Stallion Breeding Report on file with APHA for the appropriate breeding year, the add-a-mare filing fee will apply.
    - b. DNA Genetic Testing. All *IR* breeding stallions must have their DNA genotype on file at a laboratory approved by the Association in accordance with the procedures adopted by the Association.
      1. If you have a Quarter Horse stallion whose DNA genetic type is already on file at the American Quarter Horse Association (AQHA), we will place their results on file at no charge to you. Simply notify APHA by letter or telephone.
      2. The American Jockey Club, in order to release the *DNA* results on a Thoroughbred stallion, requires that APHA submit a written authorization letter from the recorded owner of the stallion, giving APHA permission to use the *DNA* on file with Jockey Club. The authorization letter must be sent to the Field Services Department at the American Paint Horse Association. Upon receipt of the letter, we will write the Jockey Club requesting a copy of the *DNA* results. Once the results are received by the APHA, they will be placed on file at no charge to you.
      3. If DNA results are not available or on file through a lab not approved by APHA, DNA kits may be purchased through the APHA office.
  3. Original Owner of Foal. Per Rule RG-070, the recorded owner of the dam at the time of foaling (OTF) is responsible for registration of the foal and will be listed on the registration application and the certificate of registration as the

- first owner of the foal. The OTF/applicant will be held responsible for the documentation supplied to register the foal in question. However, the current owner of a *IR* foal (as recorded on the *IR* certificate of registration) can sign as Original Owner of Foal, on behalf of the original owner if the original owner is not available.
4. Transfer of Foal. Per Rule RG-070, if the current recorded owner of the *IR* foal is different than the record owner of the dam at the time of foaling, a transfer report, along with a \$15 transfer fee (Non-members: \$40), must accompany the application. If the record owner of the dam at the time of foaling signed as Original Owner of Foal, then Transfer of Foal, must be completed and signed by the record owner of the dam at the time of foaling. If the current owner of the *IR* foal signed on behalf of the original owner, they can also complete and sign on behalf of the original owner. A separate transfer form, completed in its entirety, can be attached.
    - a. The owner of the dam at time of foaling, or the resultant owner, must be a current member in the exact same name or a non-member fee will be charged. Example: Joint memberships cannot be used for single ownerships and vice versa. If a non-member fee is paid instead of a membership fee, non-member fees will be charged for each transaction submitted in that name during the membership period. It is recommended that a membership be purchased in order for benefits of membership to be received.
  5. Registration Fees. The registration fee is based on the age of the horse at the time the application is submitted and the postmark date (postal meters are not acceptable for determining fees). For registration fee purposes, the age of the horse will be computed based on August 1 for foalings occurring south of the Equator. The age of horses foaled north of the Equator will be based on January 1.
  6. Parentage Verification. If there is any doubt regarding the true parentage or identification of an animal, the Association, in its sole discretion, shall determine what procedures or documents are necessary to clarify the parentage or identification of the animal in question. Such tests may include parentage verification, red factor testing, hair analysis, on-site inspection, or any other tests deemed necessary to insure that the records are accurate. If parentage verification has been completed at the *IR* through an APHA approved laboratory, it may not be necessary to repeat the testing.
    - a. If either the sire or dam is deceased, and no DNA was placed on file prior to their demise, registration of the foal may not be possible.
  7. Photographs. Four photographs of the horse must accompany the application: one direct front view, one direct rear view, and a direct view of each side for identification purposes.
    - a. If the horse has minimal markings, photographs should

also be included, clearly showing the size and underlying skin of the *area* being considered for registration eligibility.

### Internatioal Registry Breeding Chart

1st Generation	2nd Generation	3rd Generation	4th Generation
Foreign appendix (FA) registered horse; will be registered as F1 (50% APHA Appendix)			
Bred to APHA-registered horse	Resulting foal - APHA Appendix Registered - F2 (75% APHA-registered)		
	Bred to APHA-registered horse	Resulting foal-if a filly, eligible for APHA registration; if a colt - F3 (87% APHA Appendix)	
		Bred to APHA-registered horse	Resulting foal - eligible for APHA registration (F4)

### RG-025. ADVANCEMENTS

- A. A Paint stallion, mare or gelding is eligible to compete in APHA-approved shows and races on its Appendix certificate through its 3-year-old year. The Appendix certificate becomes void as of January 1 of its 4-year-old year.
- B. When a horse becomes eligible for advancement from the Appendix Registry it shall become necessary to surrender the Appendix certificate of registration. For information on any other items needed to advance a horse whose Appendix certificate has become void, please contact the APHA Registration Department.

### RG-035. LISTING OF APHA, AQHA AND JOCKEY CLUB STALLIONS FOR BREEDING

- A. A one-time listing fee (see fee schedule at front of the rule book) is required for all Paint stallions. Appendix certificates shall be surrendered with this fee and a Regular Registry certificate will be issued. Paint stallions must be listed prior to the registration of their foals in APHA.
- B. Effective January 1, 1970, stallions registered with either the AQHA, the Jockey Club or any foreign Thoroughbred registry recognized by the Jockey Club are required to be listed with the American Paint Horse Association prior to the registration of their foals in APHA. Application must be made for listing only and not registration. A stallion listing card, completed and signed by the owner of record, and a photocopy of the stallion's certificate verifying ownership must be submitted along with the listing fee. The fee for each stallion listing is referenced in the fee schedule at the front of the rule book. This identification is beneficial to the stallion owner because it gives the APHA the correct signature(s) to honor on breeder's certificates and it allows these stallions to be listed in the APHA stud book. If the stallion is transferred, a listing card with a signa-

ture of the new owner and a photocopy of the registration certificate (both back and front) establishing the new ownership must be submitted to the office, for which there is no additional charge.

- C. If an application is received, accompanied by a properly completed and signed breeder's certificate, and the stallion owner or lessee fails to properly list the stallion and/or pay the listing fee and/or sign the required listing card to make the stallion an eligible sire, the Association may suspend the stallion owner or lessee under the provision of Rule GR-060.A. of the disciplinary procedures, if stallion owner or lessee has failed to comply with this rule after due notice. Due notice shall include at least three official notices from the APHA office to the last known address as shown in the Association's records for the stallion owner or lessee. After final notice, if the stallion owner is suspended, application may be presented to the Executive Committee for possible registration without stallion listing documentation or compensation.

#### RG-040. STALLION BREEDING REPORTS

- A. Stallion breeding reports will be accepted only for Paint, AQHA or Thoroughbred (TB) stallions for which a one-time listing fee (see fee schedule at front of the rule book) has been paid. An annual breeding report fee (see fee schedule at front of the rule book) must accompany each breeding report. The owners or lessees of all registered Paint, AQHA or TB stallions must make a written report on forms furnished by the Association, include the required fees, and be postmarked (postal meters not accepted) *by the appropriate deadline:*
1. *On or before the thirtieth (30th) day of November of the year in which the mares are bred or exposed for stallion standing north of the equator, or*
  2. *On or before the thirtieth (30th) day of June of the year in which the mares are bred or exposed for stallion standing north of the equator.* This includes all mares owned by the owner of the stallion as well as outside mares *that are bred to said stallion during that breeding season.* This report shall include all breeding dates or dates of exposure. Specific dates of breeding should be reported as accurately as possible to avoid delays in processing registrations. Non-specific breeding dates, (for example, January 1, 2003 through December 31, 2003), may result in overlapping exposure dates if mare is bred to another stallion that season. Such overlapping exposure dates may require parentage verification of resulting foal. **EXCEPTION: Only Paint mares need to be reported by the owners of AQHA or TB stallions.** However, if application is for registration of a Paint or solid foal with Quarter Horse and/or Thoroughbred sire and dam, a stallion breeding report must be submitted with the application.
- B. Any stallion owner not submitting a stallion breeding report with the required fees *by the filing deadline* must pay a **late** charge; all fees due including the late charge must be paid

before the report will be accepted. (See fee schedule at front of the rule book for late charge and filing fees.) *Such reports for stallions standing north of the equator must be postmarked on or before November 30 of the breeding season; for stallions standing south of the equator, such reports must be postmarked on or before June 30 of the breeding year.*

- C. There will be a fee (see fee to correct stallion report at front of the rule book) to add a mare to any stallion breeding report which has been filed with the APHA office.
- D. If an application is received, accompanied by a properly completed and signed breeder's certificate, and the stallion owner or lessee fails to file a properly completed and signed stallion breeding report accompanied with the required fees, the Association may suspend the stallion owner or lessee under the provision of Rule GR-060. A. of the disciplinary procedures, if stallion owner or lessee has failed to comply with Rules GR-060. A. and RG-040., after due notice. Due notice shall be the same as specified in RG-035.C. After final notice, and if the stallion owner is suspended, application may be presented to the Executive Committee for possible registration without stallion report documentation or compensation. Exception: Applications for registration for foals produced from two Quarter Horses or a Quarter Horse and a Thoroughbred or two Thoroughbred parents will not be processed without submission of all required documentation and payment of all applicable fees.
- E. All breeding stallions must be genetic tested by DNA. The owner or lessee of such stallion shall at his own expense, file with the Association a written report of the stallion's genetic test by DNA, obtained from a laboratory approved by the Association and in accordance with procedures adopted by the Association. Presence of an Association observer at the time the DNA sample is obtained is not required. Once a stallion's genetic test by DNA is filed with the Association, it is not necessary to repeat such filing annually, except as requested by the Association.
  - 1. If a stallion's genetic test by DNA is on file with an APHA-approved laboratory, it would not be required again if the owner of record gives APHA written permission to obtain the genetic testing by DNA results from the appropriate laboratory.
  - 2. Failure to meet genetic testing by DNA requirements may result in possible disciplinary action. (See Rule GR-060.A.)

#### **RG-045. BREEDER AND BREEDER'S CERTIFICATE**

- A. The breeder of a horse shall be the recorded owner of the dam at the time of service, except when a mare is held under lease at time of breeding (and written notification of such lease signed by the lessor is on file with APHA at the time of registration), in which event the registration certificate shall show the lessee as the breeder.

- B. A breeder's certificate signed by the recorded owner(s) of the sire at time of service must be submitted with application for registration. The dates on the breeder's certificate and the stallion breeding report must correspond, or the Registration Department Head may require a corrected breeder's certificate and/or stallion breeding report, whichever is necessary. EXCEPTION: If applicant was the recorded owner of the sire and dam at time of service, a breeder's certificate is not required.
- C. When a stallion is bred under a lease agreement, notice of which is filed with the Association office, the Association will accept only the signature of such lessee or lessee's authorized agent on breeders' certificates and stallion breeding reports for breedings which occurred during the effective period of the lease.
- D. Upon cancellation or other termination of any such lease agreement, the owner shall immediately give written notice to the Association and to the lessee, and signature of such lessee on breeders' certificates or stallion breeding reports will not thereafter be recognized except as to breedings which occurred prior to the date of termination.
- E. When written authorization (on a form furnished by the APHA upon request) has been filed in the APHA office, the Association will accept the signature of such authorized individual on a breeder's certificate. The written authorization must be signed by the record owner(s) of the horse specified in such authorization.
- F. On a breeder's certificate, the Association shall recognize the signature of any one of the joint owners of a stallion if such owner is named on the horse's current registration certificate. If such recognition is not to be permitted, or is to be limited otherwise, the joint owners shall file in the APHA office a written agreement to that effect, signed by all such joint owners.
- G. If a mare is served by more than one stallion during the season, breeder's certificates signed by the recorded owner of each stallion involved, giving the dates of service, *may be required* by the Association.
1. *If a mare is reported bred using transported semen, and this report is later denied by the stallion and/or mare owners, parentage verification of the foal may be required.*
- H. If a mare is bred to or exposed to any one stallion during a breeding season, and a period of at least thirty (30) days did not elapse before the mare was bred to or exposed to a different stallion, the foal, the stallions involved and the dam of the foal must be genetic tested by DNA in order to determine the accurate parentage of the foal. *In cases when more than 30 days elapsed between breedings; however, when the foaling date of the foal or other factors make accurate parentage determination impossible, parentage verification may be required before the foal can be registered. Such determination is at the sole discretion of APHA.* The APHA will not be responsible for any cost incurred for this procedure.
- I. No person shall make any alterations to information on breeders' certificates. A breeder's certificate on which information

has been changed shall not be acceptable for the purpose of registering a horse.

## **RG-050. REGISTRATION AND TRANSFER FEES U.S. FUNDS ONLY**

A. **All fees are based on date postmarked (postal meters not accepted).**

B. **Registration rates for APHA members and non-members\*\*, in addition to miscellaneous fees for processing various requests, are listed in the front of this rule book.**

\*\* By paying this amount, you automatically will receive 12 months of membership in APHA and can take advantage of discounted fees on future transactions. If, for any reason, you do not want to become a Member of APHA, please indicate that in writing each time when submitting work to be completed, and all transactions will be completed at the non-member fees indicated.

C. **PROCESSING FEE**

1. When application for registration is received, researched and/or processed by the Registration Department and then a request is received to cancel and refund or credit the registration fee, an **office processing charge** will be withheld from the requested refund (see fee schedule). **NOTE: THE OFFICE PROCESSING FEE FOR EACH REGISTRATION FEE IS NON-REFUNDABLE (SEE FEE SCHEDULE AT FRONT OF THE RULE BOOK).**

2. **A processing fee will be charged on all other registration work that is not processed to completion.**

D. **RUSH FEES**

1. Rush work will be determined as any registration papers or work requested in less than four weeks, (20 working days) from the date they are received by the Association office. A rush fee for **each** registration application or work, in addition to the regular fees, must accompany the application or work. A rush fee is not refundable in the event that a registration certificate or work requested is not issued due to circumstances beyond the control of the Association. Requests for rush service must be clearly identified on the outside of the envelope as "RUSH" and contact/ mailing information, including daytime telephone number, must be included with the request.

2. All fees on rush work must be paid by certified check, money order or credit card. Processing time for rush registrations is a minimum of ten (10) working days; for rush transfers a minimum of five (5) working days; and for miscellaneous work (i.e., duplicate certificates, color changes, status changes, etc.) a minimum of ten (10) working days based on date received by the APHA office. Free priority return mail or faxed copy of certificate is included (see fee schedule in front of book).

E. **COMPUTER FLAGGING FEE**

APHA may charge a fee for requests to place notes, comments, etc., in the APHA computer regarding a particular horse or file. (See fee schedule at front of the rule book.)

## **RG-055. GENERAL PROCEDURES FOR HANDLING REGISTRATION APPLICATIONS**

- A. When an application for registration is received from any person(s) or business entity (hereafter applicant), the application shall be referred to the registration department. The registration department shall review the application and may take the following action:
  - 1. Approve the application for registration.
  - 2. Request additional information and delay further action until the information is received.
  - 3. Refer the application to the Registration Review Committee if it appears that the registration application may not be approved for any reason.
- B. If the application is referred to the Registration Review Committee (see Rule RG-060.), the Registration Review Committee will review the request for registration and may take the following action:
  - 1. Approve the application for registration.
  - 2. Request additional information and/or offer the opportunity of a field inspection, when appropriate, and delay further action until the information is received or the field inspection is completed. (See Rule RG-115. for inspection procedures.)
  - 3. Notify the applicant that it appears the horse may not be eligible for registration, specifying the reasons, and offer the applicant an opportunity to have a hearing.
- C. If the applicant desires a hearing, the Executive Committee will schedule a hearing to consider the application for registration.

## **RG-060. REGISTRATION REVIEW COMMITTEE**

- A. The Registration Review Committee shall consist of three or more persons appointed by the Executive Secretary. This committee shall be responsible for considering registration applications or problems referred to it by the Registration Department.

## **RG-065. REGISTRATION DECISIONS**

- A. In all proceedings concerned with or affecting the registration and records of the Association, and in all disciplinary actions, the burden of resolving any doubt as to the true parentage or identification of an animal shall be upon the applicant, owner, lessee or other member or members involved, and the determination, decision and action of the Executive Committee upon all such questions shall be final and binding upon all parties.
- B. In the case of any doubt regarding the true parentage or identification of an animal, the Association, in its sole discretion, shall determine what procedures or documents are necessary to clarify the parentage or identification of the animal in question.
- C. In the case of any doubt regarding the true parentage or identification of an animal, presence of an Association observer at the time blood/DNA may be obtained is required, and taking into consideration the results of each test and such other infor-

mation as may be available, the Executive Committee may authorize such corrections in the records as may be determined to be necessary or appropriate.

## **RG-070. GENERAL REGISTRATION RESPONSIBILITIES AND REQUIREMENTS**

### **A. RESPONSIBILITIES**

1. The recorded owner of the dam at time of foaling (OTF) is responsible for the registration of the foal and will be listed on the registration application and the certificate of registration as the first owner of the foal.
2. On a registration application, the Association shall recognize the signature of any one of the joint owners of an animal if such owner is named on the dam's current registration certificate.
3. Additionally, the Association shall recognize the signature of any partner when a partnership is a recorded owner of the dam. If such recognition is not to be permitted or is to be limited otherwise, the joint owners or partnership shall so advise APHA in writing.
4. One of the recorded owner(s) of the dam at time of foaling must actually sign the registration application blank and will be held responsible for the documentation supplied to register the foal in question. The original owner (or recorded lessee) must have a valid membership for the year in which the application is submitted or a non-member fee will be required.

B. If registrations or transfers are to be obtained, applicant must apply for the membership in exactly the same name that the registrations or transfers are to be recorded: either the desired name of the individual, the exact name of a partnership, or the corporate name (with partnership or corporate names accompanied by the signature of the authorized agent as it is to appear on the applications for registration, transfer, stallion listing card, etc. Note: Signature authorization must be on file in the APHA office, see Rule RG-080).

C. **REQUIREMENTS:** To register a horse with the American Paint Horse Association, the recorded owner of the foal's dam at the time of foaling shall submit a registration application completed and properly signed, a completed and signed breeder's certificate, the correct registration fee and the required photographs. (See Rule RG-040. A.) If an application is submitted and the required photographs and fees do not accompany the application, the application may not be processed until the lacking fees or photographs have been submitted. Fees charged will then be based upon the new postmark date (postal meters not accepted). Required photographs shall include those requested in Rule RG-090. Documentation by physical evidence that the horse meets the color requirements for the Regular Registry (See Rule RG-110.) must be supplied. Such evidence shall include, but not be limited to, photographs which indicate the size of the *potential qualifying area* and the color of the pigmentation beneath the *qualifying area*.

1. The application shall be complete in all respects including breeding and signatures. **The burden of proof in all matters is the responsibility of the applicant and all correspondence for additional information will be initially directed to the applicant.**
2. Each registration application must be completed and signed by the owner of the individual's dam at the time of foaling, by the dam's lessee (if record of the lease is on file with the APHA), or by a person authorized to sign for the owner or lessee (if record of the authorization is on file with the APHA) in order for the foal to be eligible for registration.
3. If the sire of the foal being registered is a numbered Quarter Horse, an Appendix Quarter Horse or a Thoroughbred recognized by the Jockey Club, a stallion listing is required which shall include a photostatic copy of the registration papers (both back and front, showing ownership), a stallion listing card completed and signed by the owner of the sire at the time of service to show correct ownership and the listing fee (see Rule RG-035. and the fee schedule at front of the rule book).
4. If the dam of the foal to be registered is a Quarter Horse, an Appendix Quarter Horse or a Thoroughbred recognized by the Jockey Club, a photostatic copy of the registration papers (both back and front) must be submitted. An enrollment fee (see fee schedule at front of rule book) must be submitted if the foal is the mare's first registered Paint foal.

#### **RG-075. MEMBERSHIP**

- A. The recorded owner of the dam at time of foaling (OTF), when applying for the registration of a horse, must have a membership in the exact same name, partnership name or corporate name (accompanied by the signature of the authorized agent) as it is to appear on the application(s) for registration, or a NON-MEMBER fee will be charged. Membership name may not exceed 30 characters (letters and spaces). EXCEPTION: If the horse is to be registered to any other name than the owner of the dam at time of foaling (OTF), the signed application must be accompanied by a signed transfer report and transfer fee and the BUYER listed on the transfer report must be a member or a NON-MEMBER fee will be charged (see Rule RG-155.).

#### **RG-080. SIGNATURE AUTHORIZATION**

- A. When an animal is owned by a company, ranch, farm, club, corporation, university or school, or partnership (of related or unrelated persons), this Association must have an authorization form on file to indicate who may sign documents for that entity. Written authorization is also required when an individual owner appoints another individual to sign in his or her behalf. (Authorization forms are available upon request from the

APHA office.) (See fee schedule in front of the Rule Book for filing fee.)

- B. When a horse is placed in a minor's name, the minor's signature will be required on all transactions related to the horse. The signature of a parent or legal guardian will not be accepted by the Association unless a signature authorization, power of attorney or other appropriate legal document is on file with the APHA. *Such documentation should include the birth certificate showing the minor's birthdate and a statement or legal document from the parent or legal guardian attesting that he/she may also be signing on behalf of the minor.*
- C. When the recorded owner of an animal is deceased, the Association or representative must have legal documentation on file appointing the agent or representative for the estate (Letters of Testamentary, Letters of Administration, etc.) and bearing the original certificate or seal of the clerk of the probate court. In the event there was no formal probate of the estate, an Affidavit of Heirship must be completed by the heirs and notarized. (Affidavit of Heirship forms are available at the APHA office upon request at no charge.)
- D. Authorization of agent may be canceled by written notification signed by record owner or recorded lessee. Such termination of authorization will take effect on date received by Association office.
- E. When an authorization is granted by a lessee, that authorization will remain in effect until the date that the cancellation of the authorization or termination of lease is received in the Association office.
- F. **Affidavits of Heirship.** In the event there is no formal probate of a person's will or estate, this form is available from the APHA upon request at no charge. It must be signed in the presence of a Notary Public by all heirs and submitted with a certified copy of the death certificate and will. If an owner of record dies intestate, then an Affidavit of Heirship will be accepted if it is signed by all of the deceased's statutory heirs and is accompanied by a copy of the statute identifying such statutory heirs. Affidavits of Heirship shall also specify which person, or persons, the heirs authorize to sign on behalf of the deceased owner.

### RG-085. LEASES

- A. For the lease of a horse to be recognized by the Association whether for breeding, racing, etc., (*leases will not be recognized to establish ownership eligibility in APHA approved shows or contests*) written notice of its existence shall be filed with the Association on forms provided by APHA, signed by both the lessor and lessee, and submitted with applicable fees (see fee schedule at front of the rule book) and accompanied by a copy of certificate (both front and back) on AQHA or TB horses. The notice shall provide the effective date of the lease and the termination date. If it is necessary that the lease be canceled prior to the termination date provided, it may be terminated by written notice giving termination date, signed by

both the lessor and lessee. No additional fee shall be charged for termination, whether automatic or by subsequent notice thereof.

- B. In regard to Association procedures, recordation of notice of lease authorizes a lessee to execute all documents pertaining to the recognized activities of breeding, racing, etc., regardless of any limitations in the actual lease agreement. Enforcement against the lessee of limitation on the use of the horse and/or any other terms of the contract or lease, is the sole responsibility of the lessor.
- C. During the effective term of the lease, the Association will not record subsequent changes in ownership until the lease is terminated, unless the transfer shows the lessee as the new buyer. The date of sale in such a case will become the date the lease is terminated.
- D. Transfer of ownership arising from recognized claiming races will terminate such lease. (See Rule RG-155. N.)

### **RG-090. PHOTOGRAPH REQUIREMENTS**

- A. All applications for registration must be accompanied (see Rule RG-070.C.) by four clear photographs, one showing each side of the horse, one showing the front view of the horse, and one showing the rear view of the horse. Pictures will be kept permanently on file. Good, clear color pictures are preferred. Do not trim photos. *Polaroid and digital photographs may be accepted but are not recommended. Unprocessed film or disks will not be accepted for registration purposes.* If used, polaroid pictures should be properly coated to prevent fading and be free of trash and debris. Polaroid pictures should not be mounted. Maximum size of photos preferred is not to exceed 4 x 6 inches.
- B. If the “natural Paint marking” that is believed to qualify the animal for the Regular Registry is of minimal size or is not clearly visible in the four basic photographs, additional pictures must be submitted.
  - 1. The additional pictures should be of good quality (clear and in focus). 35mm photographs are recommended as Polaroid pictures often lack the clarity needed. Digital photos may not be accepted for determining registration eligibility.
  - 2. Care should be taken that the photographs clearly show all white markings, that the area to be photographed is clean, and that the *potential qualifying area* is clearly visible. It may be necessary to clip any excess long hair from the area. Do not shave the *area*.
  - 3. The additional photographs submitted should include the following:
    - a. One *photograph*, taken as close to the *potential qualifying area* as possible, but to include the entire *potential qualifying area*.
    - b. One photograph with the ruler held beside the *potential qualifying area* for size comparison. Be certain the size calibrations are clearly visible and the

ruler is held in such a manner that it does not block the view of the *potential qualifying area*. *The photograph is to be taken so the potential qualifying area and the ruler are clearly visible. The outside perimeter of the potential qualifying area should be clearly definable.*

- c. The last *photograph* taken should clearly show the unpigmented skin under the *potential qualifying area*. It may be necessary to clip part of the *potential qualifying area* with surgical blades or to shave the *area* so that the unpigmented skin is visible. If the hair coat on the *potential qualifying area* is short, wetting the area may aid in making the unpigmented skin visible. **Under no circumstance should this photograph be taken first.** Closely clipping or shaving the *potential qualifying area* will eliminate all definition of the *area* and make it impossible to procure the other required photographs.
- C. Stand approximately 15 feet away from the horse when taking photos so that the entire horse image is clearly visible in the photo.
- D. Four pictures are required on Breeding Stock applications for identification purposes. (Refer to RG-090. A. for specific photograph requirements.)

#### RG-095. AGE COMPUTATION

- A. The age of a horse is computed by the calendar year starting on January 1 of the year foaled. A horse is a weanling during the calendar year in which it is foaled; it is a yearling during the first calendar year following its foaling date, regardless of the time of year foaled.
- B. When according to the Association's records, a horse has lived twenty-five years past January 1 of its foaling year, and if there is no evidence of activity (showing, breeding, etc.) for a period of three (3) years, it will be presumed dead and its registration file will be automatically marked as dead. The horse is then ineligible for registration of its offspring foaled after that date or for participation in APHA approved events. If the horse has not actually died, and its owner wishes to reinstate its registration certificate, the owner may contact the Association and provide satisfactory evidence that the horse is alive, which the owner will be required to do on an annual basis.
- C. Tooth Examination. A horse is not eligible to participate in APHA-approved events if its age as determined by Examination of its teeth does not correspond to the age shown on its registration certificate. Such determination by tooth examination to be made in accordance with the current Official Guide for Determining the Age of the Horse as adopted by the American Association of Equine Practitioners.
  1. Every exhibitor, owner or trainer shall, on request by APHA, a show manager or racing steward, permit such examination to be made by a representative of the Association and/or a licensed veterinarian. Refusal to comply with such request shall constitute grounds for

- immediate disqualification of the animal from the APHA event in progress and all other APHA-approved events shall constitute grounds for suspension of Association membership.
2. Should such examination show the animal's age does not correspond to the foaling date shown on its registration certificate, such examination shall constitute sufficient evidence that the animal's age shown on its registration certificate is erroneous. The animal automatically shall be suspended from participating in the APHA event in progress and any future events eligible for approval by the Association, pending a hearing before the Executive Committee.
  3. The exhibitor, owner or trainer shall, on request by APHA, a show manager or racing steward, deliver the animal's registration certificate to the requesting party, who shall immediately forward the certificate and affidavits from the person or persons making such examination and findings to the Executive Secretary of the Association.
  4. At a time and place designated by the Executive Committee, a hearing will be held at which time the animal's recorded owner and/or breeder shall provide evidence to substantiate the foaling date shown on the registration certificate. In the absence of substantial evidence to the contrary, the Executive Committee of the Association may cancel the animal's registration and take appropriate action against the person or persons involved.
  5. If the pedigree is substantiated, but the age discrepancy remains unresolved, the Executive Committee may direct an appropriate notation be made on the certificate to allow the horse to be used for breeding purposes, but prohibiting its participation in approved events.

#### **RG-100. NAMING A HORSE**

- A. Each horse offered for registration must be given a name acceptable to APHA, not to exceed twenty-one (21) letters and spaces, which does not conflict with the name of any other APHA-registered horse.
- B. No Arabic or Roman numerals or punctuation marks, i.e. apostrophes, are permitted in a name.

#### **RG-105. NAME CHANGE REGULATION**

- A. The name of a horse that is registered may be changed, if requested, upon submission of the original certificate, an additional certificate photo and payment of the appropriate fee (see fee schedule at front of the rule book); however, in no case will the name of a horse be changed if the following conditions exist:
  1. It has started on an APHA-recognized track; or,
  2. It has performed in an APHA-approved show or contest and,
    - a. it has earned one or more points; or,

- b. it has been named grand or reserve champion; or,
- c. it has a show record based on class wins; or,
- 3. It has compiled a record in non-point earning programs recognized by APHA, such as, but not limited to, Paint Alternative Competition (PAC) or Ride America; or,
- 4. It has registered offspring.
- B. Upon receipt of a name change request, APHA will forward affidavits to the previous owner(s). Once all affidavits are returned to the Association properly completed, signed and notarized, the Association will process the name change request.
- C. Rush service cannot be provided on horse name changes.

### **RG-110. COLOR REQUIREMENTS**

- A. A horse meeting bloodline requirements outlined in Rule RG-015. must have a definite “natural Paint marking”.
- B. For the purpose of this rule, the term “natural Paint marking” shall mean a predominant hair coat color with at least one contrasting area of solid white hair of the required size with some underlying unpigmented skin present on the horse at the time of its birth. This solid white area must be in the prescribed zone depicted in the illustration below. In the event the horse has a predominantly white hair coat, the term “natural Paint marking” shall mean at least one contrasting area of the required size of colored hair with some underlying pigmented skin present on the horse at the time of its birth. This colored area must be in the prescribed zone depicted in the illustration below.
- C. The “natural Paint marking” as described in B above must extend *more than two-inches (2”) and be in the prescribed zone depicted in the illustration below.*
- D. The “natural Paint markings” on a horse with both parents registered as described in Rule RG-015. may be anywhere on the horse’s body or legs behind a line:
  - 1. (reference point 1) from the base of the ear forward horizontally to the base of the other ear; or
  - 2. from the base of the ear to the corner of the mouth; or
  - 3. from the corner of the mouth, under the chin, to the other corner of the mouth; or
  - 4. (reference point 2) above a level line around the leg midway between the center of the knee and the floor of the chest; or
  - 5. (reference point 3) the point represented by a level line around the leg midway between the point of the hock and the center point of the stifle.
  - 6. The “natural Paint marking” need not be visible from a standing position.
  - 7. Non-qualifying areas include but are not limited to the following locations:
    - a. Eyeballs;
    - b. Lips of vulva;
    - c. Shaft of penis;
    - d. Inner sheath not visible without physical manipulation of the area.

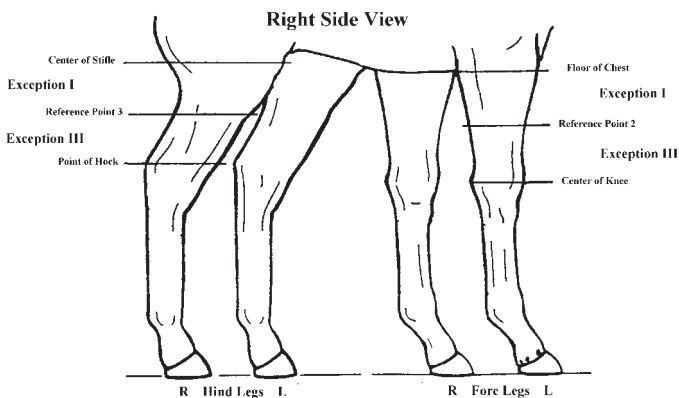
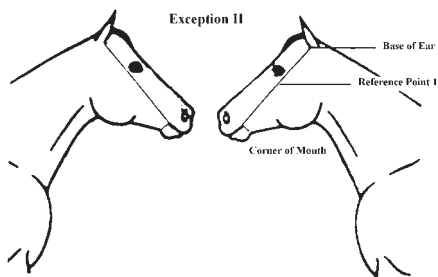

E. To be eligible for registration in the Regular Registry, a horse must possess one additional Paint Horse trait (see RG-110.F.) that need not be visible from a standing position if the “natural Paint marking”:

1. **EXCEPTION I:** occurs in an extension of a high stocking beyond reference point 2 or reference point 3. The “natural Paint marking” must extend *more than 2-inches*, be one solid white *area* and have some underlying unpigmented skin. The extension must be in excess of two inches above the line specified (either horizontally or vertically).
2. **EXCEPTION II:** occurs in an extension of a face marking beyond reference point 1. The “natural Paint marking” must extend *more than 2-inches*, be one solid white *area* and have some underlying unpigmented skin. The extension must be in excess of two inches beyond the line specified (either horizontally or vertically).
3. **EXCEPTION III:** which extends *more than 2-inches* and occurs between the center of the knee and reference point 2 or the point of the hock and reference point 3 and is NOT connected to a stocking. The “natural Paint marking” must extend *more than 2-inches*, be one solid white *area*, and have some underlying unpigmented skin. The *potential*

qualifying area must be in excess of two inches above the center of the knee or point of the hock (either horizontally or vertically). When measuring the white marking in all instances, the white marking must *exceed 2 inches*; to clearly show that it is in excess of two inches, *a ruler may be used*.

- F. Additional Paint Horse traits for purposes of this registration rule are listed below. These traits alone do not qualify a horse for the Regular Registry.
1. White leg markings extending above the knee and/or hocks;
  2. Glass, blue or watch eye(s);
  3. Apron face or bald face, described as outside a line from the inside corner of the eye to the inside corner of the nostril;
  4. White on the jaw or lower lip;
  5. Blue zone around a “natural Paint marking”;
  6. Two color mane, one color being natural white;
  7. *Dark areas or freckles in white hair on the face or legs*;
  8. White areas in the non-visible zone, excluding the head, completely surrounded by a contrasting color;
  9. A contrasting area of another color in the non-visible zone including the head, on the predominantly white horse.
- G. Any horse registered in the Regular Registry which has marginal color, or color which may not be easily observable, shall have noted in the “remarks” section of their registration certificate the size and locations of the qualifying area. If inspected, the date of inspection shall be noted.

### **RG-115. INSPECTION PROCEDURES**

- A. Whenever the Registration Review Committee finds it impossible to make a clear decision on a horse’s registration eligibility according to quality, amount or appearance of the contrasting color and/or the underlying skin based on pictures, a visual inspection may be required before further action is taken on the registration application. In such instances, the owner of the horse in question must submit an inspection fee (see fee schedule at front of the rule book) and pay mileage and expenses of the designated inspector.
- B. The Executive Committee will designate persons to serve as inspectors.
- C. After conducting an inspection, the inspector shall fill out a complete report on the horse in question and submit that report to the Registration Review Committee for consideration.
- D. An inspector shall not discuss his report with any person other than APHA staff or representatives. Any inspector violating this rule may be subject to disciplinary action.

### **RG-120. UNNATURAL MARKINGS**

- A. *An unnatural marking will not be considered as a potential qualifying area* for purposes of registering a horse with the American Paint Horse Association. *An unnatural marking, for*

purposes of this rule, is any marking that was not present at the time of birth. *Brands and tattoos are considered as additional identification and not considered as unnatural markings.*

- B. A person shall not place an unnatural marking anywhere on a horse.
- C. Any unpigmented skin, or white hair that was not present on the horse at the time of its birth, shall not be used in consideration of registration eligibility and must be noted on the registration application.
- D. The Association may require a visual inspection and/or the taking of hair and skin samples prior to approving any horse for registration with the American Paint Horse Association. All costs incurred in connection with this testing shall be paid by the person applying for the registration, and the horse will not be registered until such costs are paid. APHA may require an appropriate deposit prior to inspection arrangements being made.
- E. Any time the Association has cause to believe that a horse registered with the American Paint Horse Association has, or may have, an unnatural marking, the Association may require a visual inspection of the horse, and may also require that hair and skin samples be taken from the horse. Hair and skin samples will be taken by a licensed veterinarian and be sent to an American Paint Horse Association-approved laboratory for analysis.
- F. A horse's registration certificate may be canceled any time an owner, trainer, or lessee refuses to make a horse available for a visual inspection by an American Paint Horse Association representative or for the taking of hair or skin samples by a licensed veterinarian selected by the APHA.
- G. A horse whose *potential qualifying area* is found to contain an unnatural marking will be rejected for registration *in the Regular Registry*, or if previously registered, its *Regular Registry* registration certificate will be canceled. Any person involved with placing an unnatural marking anywhere on a horse, or registering or attempting to register a horse with an unnatural marking will be subject to disciplinary action by the Association.
- H. The decision of the Executive Committee with respect to unnatural markings, and matters related thereto, are final and binding on all parties.

#### **RG-121. SCARS AND BRANDS**

- A. All scars and brands appearing on a horse should be shown on the registration certificate.
- B. Scars and brands not appearing on the certificate will be added by the Association free of charge if the recorded owner submits the registration certificate, a diagram showing the shape and location of the scar or brand and the date of injury or branding, if known.
- C. Any freeze branding shall be reported and be accompanied by a clear photograph of the brand area.

## **RG-125. GELDED HORSES**

- A. When a horse has been gelded, the date of castration, the owner of record's signature, and the original certificate should be returned to APHA so this fact may be recorded. The registration certificate, marked "gelded" will be returned to the owner of record.
- B. Before a colt will be awarded points as a gelding, its status must be received in the APHA office. (See Rule SC-175.G.)

## **RG-130. TATTOOING**

- A. Refer to Racing Rule RA-040. A.

## **RG-135. DUPLICATE AND CORRECTED CERTIFICATES**

- A. A duplicate certificate is a new registration certificate that is issued when the original has been lost or destroyed. It may be issued by the Association when sufficient proof of loss and proper identification of the horse has been submitted to the Association office. The current recorded owner must file the proper affidavit, duly notarized, completed in all respects and stating the circumstances under which the original certificate was lost or destroyed and pay the required fee (see fee schedule at front of the rule book). Such affidavit must be accompanied by two current photographs, a direct right side view and a direct left side view of the horse. If it is determined that a duplicate has been issued based on false or inaccurate information, the applicant/record owner/affiant may be subject to disciplinary action and the duplicate certificate may be recalled.
- B. If the horse has been tattooed by an APHA representative and the owner can provide the APHA with the number tattooed in the horse's lip, the photographs of the horse will not be required.
- C. If the present owner is not indicated in the Association files to be recorded owner, he shall provide the Association with an affidavit from the last owner of record in order to obtain the duplicate registration certificate. The affidavit shall identify the person to whom he delivered the registration certificate.
- D. In regard to involuntary transfer of title situations, including but not limited to court judgments and stableman's lien or security interest foreclosure, when it is proven to the Association's satisfaction that a previous owner is unavailable for affidavit concerning the original certificate or refuses to implement the court's judgment by delivering the original certificate for transfer, at the Association's discretion and in the interest of equity, requirement of affidavit of the recorded owner may be waived and the current owner deemed eligible for duplicate certificate.
- E. In order to issue a duplicate certificate, when the recorded owner cannot be located to complete the affidavit required in Part C above, the following items are required:
  - 1. Properly completed and signed transfer reports or acceptable bills of sale reflecting each ownership change begin-

- ning with the recorded owner;
2. Notarized statement signed by each party who had the original certificate in his or her possession after the record owner;
  3. A signed statement from the actual current owner giving details of his attempts to contact recorded owner;
  4. An affidavit for duplicate certificate signed by the current owner;
  5. A full side view photograph of the horse identified in writing by the owner of the dam at the time of foaling;
  6. The duplicate certificate fee (see fee schedule at front of rule book); and,
  7. The transfer fee (see fee schedule at front of rule book) for each transfer of ownership change.
- F. **Corrections:** If a registration certificate is delivered to the APHA office to be corrected, but the items are in such order that it is not possible to issue a corrected certificate, the registration certificate will be retained in the APHA office until the correction can be completed and a new certificate issued (see fee schedule at front of the rule book).
- G. **Free corrections:** Within thirty (30) days from the time the registration certificate is mailed from the Association office, for no additional charge, the owner may return the certificate to the Association for correction of inaccuracies accompanied by the necessary documentation for the change. Thirty (30) days will be determined by the postmark when the certificate is returned. Such correction shall not include a change of name from one which has been submitted by the owner *or change of reported sire and/or dam.*
- H. **Picture Replacement Fee:** A picture replacement fee (see fee schedule at front of the rule book) is charged when the owner of record wishes to replace the photograph on a registration certificate or when requesting a new certificate showing three generations of pedigree. The Association must be provided with the original certificate, a current side view photograph of the animal and the replacement fee before the replacement certificate can be issued.
1. A picture replacement fee will also be charged if the original certificate is received in the APHA office in such condition (for instance, it has been defaced by writing on it) that it warrants a new certificate. The recorded owner will be billed for a picture replacement and a new picture will be requested for attachment to the new certificate.
- I. Upon issuance of a duplicate, corrected or replacement certificate, the original registration certificate issued by APHA, or any previously issued duplicate, corrected or replacement certificate, is thereby considered null and void. The certificate considered to be valid and in force will be the certificate with the most current issuance date, except at APHA's sole discretion. Any previously issued certificate not in force at the time of submission may be retained by APHA and the individual submitting it may be required to obtain a new certificate and pay the requisite fee(s). Failure to surrender invalid certificate may result in possible disciplinary action pursuant to Rule GR-060.D.

## RG-140. SURRENDER OF CERTIFICATE

- A. The owner of any registered animal which dies or is sold or disposed of without papers, shall notify the Association of the fact and surrender the appropriate registration certificate to the Association for proper notation. If requested, the canceled certificate will be returned to the owner.
- B. A certificate of registration is subject to correction and/or cancellation under the rules and/or By-Laws of the APHA. The APHA will not be liable for issuance of a certificate because of any mistake therein based upon an error or misrepresentation in the application thereof, and in case of such error or misrepresentation, the APHA reserves the right to cancel a certificate and the entry of the animal.
- C. Ownership of an issued registration certificate remains with the Association. No person shall refuse an Association request for return of a registration certificate; refusal to respond and/or return the certificate may be considered grounds for possible disciplinary action (see Rule GR-060. F.).
- D. Upon issuance of a duplicate, corrected and/or replacement certificate, APHA shall require the surrender of the original registration certificate, if applicable, and any previously issued certificates will be null and void.

## RG-145. STATUS CHANGES

- A. If a horse is placed in the Breeding Stock Registry and a *potential qualifying area* is later discovered which the owner feels may qualify the horse for the Regular Registry (see Rule RG-110.), the following items must be submitted:
  - 1. The Breeding Stock registration certificate;
  - 2. Good, clear color pictures which clearly show the area which might qualify the horse for registration in the Regular Registry. Such pictures should include a certificate photo, a close-up of the *potential qualifying area(s)* which clearly shows the size of the *area(s)* in question and which shows the extent of the underlying unpigmented skin;
  - 3. A signed unpigmented skin statement available upon request from APHA, certifying that the spot which would qualify the horse for the Regular Registry is a “natural Paint marking” with some underlying unpigmented skin that was present on the horse at the time of birth; and,
  - 4. The status change fee (see fee schedule at front of the rule book). If it is decided that the horse does not qualify for the Regular Registry, the status change fee (less an office processing fee) will be refunded. If accepted into the Regular Registry, a new certificate will be issued.
  - 5. A photograph suitable for use on the new registration certificate. Photo should be a direct side view (preferably the side with the Paint *qualifying area visible*). *Maximum size of photos preferred is not to exceed 4 x6 inches. Do not trim the photos.*

## RG-150. RE-REGISTRATION CERTIFICATES

- A. A re-registration certificate shall be defined as one on which there is a change in the sire, dam or foaling year. It requires a new application properly completed and signed, a notarized statement from the owner (or lessee or authorized agent for owner) of the dam at time of foaling giving details as to why the horse was incorrectly registered, a certificate photo, and a re-registration fee (see fee schedule at front of the rule book). In addition, if the foaling year is changed to an earlier year, the difference between the registration fee paid at that time and the amount which should have been paid at that time, must be remitted. The Association must be provided with the original certificate before a re-registration certificate can be issued.
- B. When the correct parentage has been established by genetic testing by DNA (presence of an APHA observer is required), the Executive Committee may, in the interest of fairness and equity towards an innocent third party, authorize re-registration without the application, breeder's certificate, and/or stallion breeding documents if, in the opinion of the Executive Committee, it is unreasonable to require these documents.

## RG-155. TRANSFERS

- A. Transfer reports will be furnished free by the Association upon request. The original registration certificate must accompany the completed transfer report with appropriate fees (see fee schedule at front of the rule book) to the Association in order for the horse to be recorded in the name of the new owner.
- B. **Transfer of Ownership:** When ownership of a registered animal is transferred (unless the transfer is "without papers"), the seller at the time of the transfer shall deliver to the buyer the applicable registration certificate together with a written report of the transfer, which written report shall be signed by the seller, who shall be the recorded owner on the records of the Association. APHA will not knowingly skip transfer(s) of ownership. Every effort must be made to complete each transfer (with appropriate fees) from the recorded owner to each subsequent owner until ownership reaches the resulting applicant/owner currently applying for transfer of ownership (see Rule RG-155.K. if one or more owners are not available).
- C. It shall be the responsibility of the seller to complete the transfer form in its entirety, to include the correct name and registration number of the horse, date of sale, name and address of the buyer and signature and address of the seller. Should a seller of a registered horse sell a horse and fail to complete the transfer form and this fact is established, the seller may be assessed a penalty of \$100 and such violations shall be published. This penalty shall not apply when a horse is consigned at a regular auction sale, where it shall be the duty of the sale manager to insert on the transfer the complete name and address of the purchaser.
- D. For each ownership change, the buyer shall forward the completed, unaltered transfer form and certificate with all applicable fees to the Association for appropriate action. If a registra-

tion certificate and transfer form are delivered to the APHA office to effect a transfer but are in such order that it is not possible to complete the transfer, the registration certificate will be retained in the APHA office until the transfer can be completed and recorded in the Association's records. To record a transfer, the responsible party shall supply the Association office with the following items:

1. The original registration certificate;
  2. A written report of the transfer on the transfer form furnished by the Association, completed and signed by the last recorded owner as the seller; and
  3. The required fee (see fee schedule at front of the rule book).
  4. *If a member, membership must be in effect as of the post-mark date (postal meters not acceptable) the original request for transfer is submitted.*
- E. On a transfer report, the Association shall recognize the signature of **any one of the joint owners** of an animal if such owner is named on the horse's current registration certificate. Additionally, the Association shall recognize the signature of **any partner** when partnership is a recorded owner. If such recognition is **not** to be permitted, or is to be limited otherwise, the joint owners or partnership shall file in the APHA office a written agreement to that effect, specifying horse's name and registration number, and signed by all such joint owners or all partners.
- F. In the event of the death of the record owner or one of the joint owners, the following shall apply:
1. Successor/owner must file with the Association a certified copy of the death certificate, Letters Testamentary appointing the executor, and/or an Affidavit of Heirship (available from APHA upon request in the event there was no formal probate).
  2. Submit a written, signed instrument of consent to transfer all horses (or listing specific horses by name and number) in the joint ownership with the deceased, or in the deceased's singular name, to the successor's ownership along with a request to transfer membership to the successor. There shall be no fee for such transfer to the successor/owner; however, there will be a transfer fee of \$15 if the horse is transferred direct from the deceased's name to a third party.
- G. In the event of joint ownership, if it is a married couple, and a divorce occurs, the following must be supplied:
1. Successor/owner must file with the Association a copy of the judicial decree, written evidence of which provides that he/she is now entitled to sole ownership of the horses(s) involved and so specifying by registered name and number (or by foaling year and name of sire and dam), or a written, signed and notarized instrument of consent signed by the terminating spouse.
  2. Upon receiving applicable documentation, APHA will then transfer to the successor all horses that are awarded to his/her ownership for a reduced fee of \$7.50 each. Also, if

- a singular membership is necessary, the successor may have the one-time privilege to amend the membership to directly reflect the successor's status, if the terminating party so agrees as part of the instrument of consent listed above.
3. If the horse was recorded to the individual ownership of one of the divorced parties, then a signed transfer and/or a copy of the judicial decree awarding the other partner the horse in question must be provided.
- H. When written authorization (on a form furnished by the APHA upon request) has been filed in the APHA office, the Association will accept the signature of such authorized individual as sufficient to complete the recording of the transfer. The written authorization must be signed by both the recorded owner of the horse specified in such authorization and the person being authorized to sign a transfer.
- I. In no case may the ownership name (whether an individual or otherwise) exceed 30 characters (letters and spaces).
- J. No person shall make any alteration on a completed transfer form or in any manner deface, change or amend the provisions of it. If altered, a new transfer form will be required at APHA's discretion.
- K. In order to record a transfer, when a previous owner cannot be located to complete the transfer report, the following items should be submitted to the Association. The Registration Review Committee will review documentation and determine if transfer can be completed without the omitted or incorrect signature (see fee schedule at front of book).
1. Notarized statement signed by the buyer providing the actual date of the transfer;
  2. Copies of canceled checks, bill of sale, or other documentation that could help establish purchase and date of sale;
  3. Copies of attempts by the buyer to contact the seller to obtain the signed transfer report(s);
  4. Notarized and signed indemnity agreement (form available from APHA);
  5. Current photographs of the horse (which must match original photographs submitted for registration); and,
  6. Affidavit for duplicate certificate signed by the current owner and/or owner of record.
- L. To correct the date of sale on a transfer recorded with the APHA, it is required that the Association be provided with signed statements from both buyer and the seller on the transfer report that is to be corrected, giving the date, the horse's registration certificate and the correction fee (see fee schedule at front of the rule book).
- M. **REQUIREMENTS FOR STABLEMAN'S LIEN TRANSFER.** In order for the American Paint Horse Association to recognize a stableman's lien foreclosure and record the resulting new ownership, the APHA must receive several items, including a special handling fee (see fee schedule at front of book).
1. Affidavit in the form prescribed by the APHA setting forth the factual basis creating the lien.

2. Copy of state statutes relating to the creation and foreclosure of a stableman's lien.
3. Documentary evidence, satisfactory to the APHA, evidencing that each element of the stableman's lien statute and foreclosure procedure has been satisfied.
4. Indemnity agreement in the form prescribed by the APHA.
5. Current photographs of the horse, and such parentage verification testing as may be required by the APHA.

**N. TRANSFER OF OWNERSHIP IN CLAIMING RACES.**

When a horse is claimed at a recognized track, the racing secretary shall collect a transfer fee and membership fee, if necessary, from the claimant which shall be forwarded to APHA together with the registration certificate, a written report of the race showing the date of the race, and the name and address of the person claiming the horse. Upon receipt of such fee(s), certificate and report, APHA shall make the transfer without being signed by the recorded owner. If the notice of claim and the supporting documents are received by APHA within 14 days of the claim, the transfer will receive free special handling rush service. Requests for rush service must be clearly identified on the outside of the envelope as "Rush" and contact/ mailing information, including a daytime telephone number, must be included with the request.

1. If any dual-registered American Paint Horse is entered in any breed claiming race, the dual-registration must be disclosed to the Racing Secretary and its APHA registration certificate must be surrendered to the Racing Secretary at the appropriate track.

**RG-160. GENETIC TESTING BY DNA**

- A. If, in the opinion of the Executive Secretary, there is justifiable cause to question parentage of a foal, the Executive Secretary may require the foal, sire and dam to be genetic tested by DNA. The results of this test, together with such other information as may be available, may be presented to the Executive Committee for consideration and final determination of the foal's parentage as recognized by the Association. The owner of the foal in question will be required to make a deposit of \$60 per horse (plus reasonable costs of the APHA identifier) with the Association for the purpose of genetic testing by DNA.
- B. At the discretion of the registration department head or Registration Review Committee, pictures may be requested of the sire and dam of any tobiano foal that exhibits definite tobiano characteristics but whose registration application does not indicate at least one tobiano parent. If in the opinion of the registration department head or Registration Review Committee, the pictures of neither the sire nor dam indicate tobiano characteristics, the registration department head or the Registration Review Committee may require the owner of the foal to make a deposit of \$60 per horse (plus reasonable expenses of the APHA identifier) to be used for genetic testing by DNA as outlined in the preceding paragraph. If the parentage cannot be verified to substantiate the application for registration, the foal then shall be declared ineligible for registration

as submitted until such time as the foal owner can produce evidence through genetic testing by DNA and correction of registration documentation (stallion breeding report and breeder's certificate). This additional genetic testing by DNA shall be conducted entirely at the expense of the foal owner.

- C. **PEDIGREE CERTIFICATION:** To certify the pedigree of an American Paint Horse, the following procedures must be followed.
1. The horse applying for certification must be genetic tested by DNA in accordance with procedures adopted by the Association at a laboratory approved by the Association. Presence of an Association observer at the time the blood/DNA sample is obtained is required.
  2. The sire and dam of the horse applying for certification must also be genetic tested by DNA. Genetic testing by DNA must be conducted as outlined in the paragraph above.
  3. **SEE FEE SCHEDULE IN FRONT OF RULE BOOK FOR GENETIC TESTING BY DNA.**
    - a. If more than one pedigree is to be certified, or an owner wishes to genetic testing by DNA other registered Paints on a random basis, **SEE FEE SCHEDULE IN FRONT OF RULE BOOK.**
  4. All expenses, including travel and/or lodging of Association observer as well as veterinarian's fees, shall be the responsibility of person applying for pedigree certification.
  5. Procedure for requesting pedigree certification is as follows:
    - a. Send a written request for pedigree certification, being certain to include name and registration number of horse(s).
    - b. Enclose appropriate fees of \$180 (includes the horse, its sire and dam).
  6. Upon completion of testing and receipt of results indicating parentage qualification, notation of pedigree certification will be placed on certificate of registration.
  7. At the owner's option, the APHA observer will place a lip tattoo on the upper lip of the horse applying for certification for identification purposes at the time the blood/DNA samples are obtained at no additional cost.
  8. For pedigree certification to be recognized by the APHA, testing must be conducted under the auspices of the American Paint Horse Association.
  9. Pedigree certificate is valid only for the horse tested. Certification through genetic testing by DNA should not be considered a guarantee by the APHA of a given horse's pedigree for prior generations.

#### **RG-165. ARTIFICIAL INSEMINATION/COOLED AND FROZEN SEMEN**

- A. A foal shall be considered eligible for registration which is conceived by artificial insemination (semen that is used immedi-

ately following collection, time lapse not to exceed 24 hours), and at the place or premises of collection, transported/cooled semen (semen that is transported from the location of collection and used within 72 hours of collection) or frozen semen (semen which has been collected and stored in a frozen state for future use).

B. A foal shall be considered eligible for registration which is conceived using cooled semen or frozen semen, if in addition to other association rules, the following conditions are met:

1. Before semen may be transported from the location of collection, the stallion owner, lessee of record or authorized agent (all hereafter shall be referred to as stallion owner) at the time of permit application, shall apply for and pay the appropriate yearly fee for a Transported and/or Frozen Semen Permit (see fee schedule at front of the rule book). This permit is effective for the calendar year (January 1 - December 31) during which the semen may be collected or used. The permit fee is non-refundable or transferable.

This permit will:

- a. Be issued to the stallion owner or authorized agent, upon receipt of the above fee and DNA genetic testing of the stallion on record with APHA.
  - b. Identify the stallion from which the collection is to be taken. Currently, either the stallion or the mare to be inseminated must be registered in the American Paint Horse Association or American Quarter Horse Association (until such time as the Jockey Club recognized the use of transported semen).
2. Once the permit has been issued, a collection-insemination certificate must be completed and sent with each inseminate by the stallion owner or authorized agent. This report requires a portion to be completed and mailed to APHA by the mare owner or authorized agent. This report will certify the identity of the collected stallion as well as the inseminated mare and date of insemination. The collection and insemination shall be overseen/conducted by veterinarians/technicians as attested by their signatures. The veterinarian/technician shall certify that the mare designated on the insemination certificate was the mare inseminated as identified by her original registration certificate. The designated copy of the report should be returned to the stallion owner by the mare owner after insemination for use in completing the appropriate stallion breeding report. The stallion owner should require that the completed form be returned prior to issuance of a breeder's certificate for registration purposes.
- a. Stallion will not be limited to the number of mares exposed to transported cooled or frozen semen during any one calendar year.
  - b. The mare owner shall contact the stallion owner to arrange for the transportation of semen. Any fees charged by the stallion owner in connection with providing transported cooled or frozen semen are between the mare owner and the stallion owner.

- c. Should the mare not conceive within the calendar year, the stallion owner must apply for a new permit and fee paid before insemination with transported cooled or frozen semen is attempted in the subsequent calendar year.
  - d. Prior to the completion of the registration application for a foal conceived through the use of transported cooled or frozen semen, the applicant shall have the DNA genetic testing of the dam and the foal on record with APHA, and the foal's parentage must be verified.
  - e. There will be a \$500 penalty fee per operating year for transporting cooled or frozen semen without a permit.
- C. The stallion service report shall include all mares exposed with transported cooled or frozen semen whether or not a mare conceives. Said service report will distinguish between artificial and natural (hand or pasture breeding) services, transported cooled, and frozen semen.
- D. In the event a stallion changes ownership, use of the frozen semen is limited to the current, recorded owner. The new owner must re-apply for a new Frozen Semen Permit before breeding with frozen semen.
- 1. Sale of the stallion will limit the use of the frozen semen to the current, recorded owner and only with the issuance of a valid Frozen Semen Permit.
  - 2. Ownership of any semen already frozen by the previous owner/lessee must be resolved between the seller and buyer.
- E. If a stallion is leased, the use of the frozen semen by the lessee is restricted to the time period (beginning to ending date) of the lease only.
- F. Death of the stallion will preclude the use of frozen semen to a period of 24 months from the date of death.
- G. Gelding of the stallion will preclude the use of the frozen semen as of the date of gelding.
- H. APHA will not become involved in disputes arising between current or previous owners of stallions and/or mare and stallion owners. Stallion owners (lessees or authorized agents) must take all necessary steps to protect their right to the use of their stallion's frozen semen. They cannot use the Association to protect, defend, or enforce the use of the semen. Any such disputes are contractual in nature and must be resolved by the individuals through whatever means at their disposal. Mare owners must take all necessary steps to protect purchase of the semen and issuance of a valid Breeder's Certificate.

### **RG-170. EMBRYO TRANSFER**

- A. In regard to a horse foaled by a mare which is not its genetic dam, but transferred to her by an embryo or oocyte transfer technique (hereafter referred to as a "transfer"), the offspring shall be eligible for registration if, in addition to all other Association registration rules, the following conditions are met:
- 1. The APHA should be notified of the intent to perform transfer by the dam's recorded owner or authorized agent

prior to the intended transfer. The notification must include:

- a. The name and registration number of the donor mare, the breeding stallion and the name and location where the intended transfer is to take place.
  - b. The embryo permit fee (see fee schedule at the front of the rule book) must be paid each year that a transfer is to be performed, and once paid, the fee is not refundable nor can a substitution be made.
  - c. Upon good cause shown for innocent mistakes(s), in its sole discretion, the Executive Committee may accept filing of late notification and in those cases it deems appropriate, assess a late filing penalty.
2. Each transfer of an embryo may occur at the same location as recovery. The transfer must be completed within 72 hours of recovery of the embryo if transferred on the same premises.
  3. An embryo may be transported from the premises where the donor mare was located at the time of its removal from her for use in a recipient mare at another location, but implantation of such embryo must occur within 24 hours of its removal from the donor mare. To be eligible for such embryo transportation, notice of the intention to transport the embryo shall be given the Association in conjunction with advanced notice of intended collection as specified above.
  4. The breeder's certificate and application for registration for a foal resulting from a transfer may be signed by the owner of the dam at time of breeding (embryo transfer), if they have retained the recipient mare, unless a signed statement to the contrary has been submitted to the APHA office prior to foaling.
  5. Has its pedigree verified through genetic testing of foal, sire and donor mare, and by such other testing as APHA deems necessary, all expenses of which will be the registration applicants.
  6. An Association representative and/or Association approved veterinarian is present during the collection and transfer procedure, at the Association's discretion.
  7. A donor mare may produce multiple embryos in a calendar year.
    - a. When a foal is the result of a transfer, that fact will be noted under the "remarks" on its registration certificate.
  8. Any AQHA, TB or APHA (Regular or Breeding Stock) mare is eligible for embryo transfer.
  9. If a mare is designated with the Association for embryo transfer, but the procedure is not attempted in the designated year, to avoid the necessity of genetic testing by DNA, the Association must be notified by December 1 of the designated year that the owner has elected not to attempt the embryo transfer. Without such notice, foals produced the following year by the designated mare are not eligible for registration without genetic testing for parentage verifica-

tion.

10. The Association may inspect the premises and practices of any party using embryo transplant procedures. The burden of verifying true parentage is the registration applicant's, and any questions of parentage shall be resolved against registration of a horse carried by a recipient mare through embryo transplant.

#### **RG-175. FORFEITURE OF FEES**

- A. Failure by any person to acknowledge any APHA correspondence relative to the registration or transfer of any horse, or any other related APHA business, will result in that file being closed and all fees forfeited. Thirty (30) days after the first request a final notice will be sent prior to closure of the file.

#### **RG-180. RE-ACTIVATIONS**

- A. If an application has been inactivated and placed in the "dead file" for any reason, the following procedure is required to reopen the file:
  1. Payment of the registration fee based on the current age of the horse to be registered.
  2. Payment of the appropriate person's current membership fee; and,
  3. Submission of any documents lacking to complete the registration when originally submitted, if any.
  4. Complete set of current photographs (front, rear and both side views).

## SHOW AND CONTEST

### SC-000. GENERAL SHOW AND CONTEST RULES AND REGULATIONS

#### Effective Date and Repeal

The following Rules and Regulations shall become effective January 1 of the current year, and thereupon all Rules and Regulations and parts thereof-heretofore in force are hereby repealed.

#### SC-005. SPECIAL NOTICE & EFFECTIVE DATE

- A. EXHIBITORS, JUDGES AND SHOW MANAGEMENT ARE RESPONSIBLE FOR KNOWLEDGE OF ALL APHA RULES.

#### SC-010. APHA TITLES AND AWARDS

- A. **APHA RESERVED TITLES AND/OR AWARDS.** All APHA titles and/or awards listed in the APHA rule book are reserved by the APHA for its express use and will be awarded to the owner of record at the time the award is earned.
- B. **APHA RECORD NOTATION.** Proper notation shall be made of all APHA Titles and Awards issued in the records of the APHA.
- C. **MEMBERSHIP REFERENCE.** Reference Rule GR-020.M. regarding APHA membership.
- D. **FRAUDULENT CLAIMS OR ADVERTISING OF APHA TITLES OR POINTS.** The registration certificate of any horse may be revoked permanently by the Association if the owner thereof fraudulently advertises claims or holds forth that this certain horse is entitled to any title or points awarded by the APHA prior to the title or points being officially awarded or recorded by the APHA, or uses a title other than the official title of the award as specified by APHA rules.

#### SC-015. APHA SUPREME CHAMPION AWARD

- A. **TITLE.** The title of **American Paint Horse Association Supreme Champion** will be awarded to any stallion, mare or gelding which has been issued a Regular Registry certificate by the American Paint Horse Association, provided said horse meets the following requirements:
1. **Number of Grand Championships.** Has been named Grand Champion in at least five (5) APHA approved A shows under five (5) or more judges.
  2. **Total Points Needed.** Has won a total of at least eighty (80) points in recognized halter and performance classes in APHA-approved A class shows or in races recognized by the APHA.
  3. **Total Halter Points.** And at least thirty (30) of those points

- have been won in halter classes. See Rule SC-060.A.
4. **Total Performance Points.** And at least fifty (50) of those points has been won in performance events or in races recognized by the APHA.
    - a. **Individual Event Points.** No more than ten (10) points may be tabulated in any one (1) event.
    - b. **Registers of Merit.** And must have earned at least one Register of Merit in each of categories II through VI of performance events as set forth in Rule SC-050.A.3.
    - c. **Racing Points.** And must have earned at least four racing points as indicated under Category VII in Rule SC-050.A.3. and have run at least one race with an official speed index of no less than 80.
  5. **Special Trophy Awarded.** In the event that this title is awarded, a special and properly engraved trophy shall be prepared and presented to the owner of the said horse at an annual Workshop or Convention of the APHA.

#### **SC-020. APHA SUPERIOR ALL-AROUND AWARD**

- A. **TITLE.** The title of **APHA Superior All-Around Horse** will be awarded to any stallion, mare or gelding which has been issued a Regular Registry certificate by the APHA, provided said horse meets the following requirements:
  1. **Superior Halter.** Must have a superior rating in halter, having earned fifty (50) or more points. See Rule SC-060.A.
  2. **Superior Performance Event.** Must have one superior rating in one performance event, having earned at least fifty (50) points in one of the recognized performance events excluding Category VIII.
  3. **Register of Merit.** Must have earned at least one Register of Merit in at least four (4) of the performance contest categories specified in Rule SC-050.A.3. excluding Category VIII.
- B. **SPECIAL TROPHY.** In the event the title of "APHA Superior All-Around Horse" is awarded, a special and properly engraved trophy shall be prepared and presented to the owner of the said horse at an annual Workshop or Convention of the APHA.

#### **SC-025. APHA PERFORMANCE VERSATILITY AWARD**

- A. **TITLE. APHA Performance Versatility Horse.** To earn this award, a horse must have earned five (5) ROMS in at least four (4) of the categories and a Superior rating must have been earned in one of these categories as found in SC-050.A.3., excluding Categories I and VIII.
- B. When the title of APHA Performance Versatility is awarded, an appropriate award shall be sent to the recorded owner of the said horse.

### SC-030. APHA SUPERIOR EVENT AWARD

- A. **TITLE.** The title **APHA Superior Event Horse** will be awarded to any stallion, mare or gelding which has been issued a regular registration certificate by the American Paint Horse Association provided said horse has earned fifty (50) or more points in one APHA approved event. **EXAMPLES:** A horse which earns a minimum of fifty (50) points in cutting will be designated as an APHA Superior Cutting Horse; with fifty (50) points at halter, it will be listed as an APHA Superior Halter Horse.
- B. **SUPERIOR EVENT TITLES.** A horse may receive this title for each separate event in which it has earned fifty (50) points. See Rule SC-060.A.
- C. **CERTIFICATE AWARDED.** When the title of "APHA Superior Event Horse" is awarded, a proper certificate shall be prepared and sent to the record owner of the said horse.

### SC-035. APHA CHAMPION AWARD

- A. **RESERVED TITLE.** In regard to all horses registered by the American Paint Horse Association, the title or term **APHA Champion** is hereby, from this date and in the future, reserved by the said Association for its express use.
- B. **THE TITLE. APHA Champion** may be awarded to any individual stallion, mare or gelding registered in the Regular Registry of the APHA after it has won a total of forty (40) or more points in competition in official shows, contests, and races approved by the APHA, provided:
1. **Number of Shows, Points and Judges.** That the points have been won in five (5) or more shows or contests and under five (5) or more judges;
  2. **Halter Points.** That at least sixteen (16) points have been won in halter classes and of these sixteen (16), a minimum of ten (10) points must be won in either A or B class shows. (See Rule SC-060.A. and SC-055.)
  3. **Performance Points and Categories.** That at least sixteen (16) of these points have been won in performance classes or contests, and with a minimum of five (5) points each having been earned in at least two (2) **different** categories only of performance events as set forth in Rule SC-050., excluding Categories I and VIII. These five (5) points must be earned in at least two (2) categories and cannot be earned in a combination of categories.
  4. **Racing and Cow Pony Race Points.** For the purpose of earning an APHA Championship, Racing or Cow Pony Race points may be used. However, both events cannot be used for tabulation of this award.
- C. **CERTIFICATE AWARDED.** In the event that the title of "APHA Champion Horse" is awarded, a proper certificate shall be prepared and forwarded to the owner of said horse.

## SC-040. APHA HONOR ROLL AWARD

- A. **TOTAL POINTS EARNED.** The Association will make annual awards based upon the number of points earned by an individual horse during that year's competition in each of the events in which points are awarded at APHA approved shows.
- B. **MINIMUM EIGHT (8) POINTS TO QUALIFY.** To qualify for any of the Honor Roll titles, trophies or certificates, the horse must have earned at least eight (8) points in that event during the year.
- C. **TROPHY OR PLAQUE TO CURRENT YEARS HIGH POINT EARNER.** The horse which earns more points during a year than any other horse has earned in that event will be the year's High-Point earner for that event and an appropriate trophy or plaque will be awarded to the horse's owner. **EXAMPLE:** 2004 Honor Roll Cutting Horse, or 2004 Honor Roll Western Pleasure Horse.
- D. **CERTIFICATE FOR HIGH POINT HORSE OF THE OTHER TWO SEX DIVISIONS.** The High-Point individual horse of the other two sex divisions for each event during the year will be so designated and an appropriate certificate shall be prepared and mailed to the owners of said horses. **EXAMPLE:** if Honor Roll horse is a mare, the other two sex divisions would be 2004 Honor Roll Cutting Stallion and 2004 Honor Roll Cutting Gelding.
- E. **HALTER HONOR ROLL.** In halter, the horse that earns the most points during the year in each sex division will receive an appropriate trophy or plaque. **EXAMPLE:** Honor Roll Stallion, Honor Roll Mare, Honor Roll Gelding.
- F. **TOP TEN POINT EARNERS OF EACH EVENT.** Each of the top ten point earning Yearlings, Two-Year-Old, Three-Year-Old, Four-Year-Old and older halter mares, stallions and geldings; Two-Year-Old Western Pleasure and Hunter Under Saddle; Junior Western Pleasure; Senior Western Pleasure; and other respective Junior and Senior Performance classes for the year in each event will be so designated and an appropriate certificate shall be prepared and mailed to the owners of said horses. Tabulation will be based on age of horse, not class description, due to combining and splitting of classes. **Example:** 2004 Honor Roll Junior (Event) Horse and 2004 Honor Roll Senior (Event) Horse.

## SC-045. APHA OPEN TOP TWENTY AWARD

- A. **HALTER AND PERFORMANCE.** Year-end recognition will be given to the twenty open horses who earn the most points in open halter and performance classes.
  - 1. **Maximum Number of Shows Counted.** Total points will be compiled on horses from January 1 through December 31. Maximum of 20 APHA approved shows, all under different judges, from which their total points will be tabulated. One alternate show will be used in case of a tie. The judge of this show will be different from the other show judges.
  - 2. **Awards.** All top twenty horses will receive an award.

## SC-046. ZONE TOP 5 AWARD

- A. This award would recognize the top five horses in each of the zones. This award is based on total cumulative points earned within the respective zone the horse is owned. Exhibitors do not have to live in the zone. (See Rule SC-105.B.3.f.-g. for states listed in the respective zone.) As long as horse/owner remain in the same zone, points will accumulate on horse (horse may be transferred to someone within the same zone).
- B. Tiebreaker System:
1. Horse with greater number of performance points.
  2. Most points earned in fewest shows.
- C. **Awards.** An appropriate award will be mailed to the recorded owner of the first through fifth place horse.

## SC-050. APHA REGISTER OF MERIT AWARD

- A. **PURPOSE.** The purpose of the APHA Register of Merit is to establish a record of excellence. Horses are advanced to the Register of Merit when they have won at least ten (10) points in the scale of points for contests in any one open event including halter. See Rule SC-060.A.
1. **ROM in Halter.** To qualify for a Register of Merit (ROM) in halter, a horse must have earned at least one of the required halter points after December 31, 1990.
  2. **ROM in Performance.** To qualify for one of the Performance Registers of Merit, horses must be entered in one or more of the APHA-approved contests shown in Rule SC-050.3.
  3. **Categories:** The following performance contests have been divided into eight categories and are approved for points and/or awards.
    - a. **Category I** Halter
    - b. **Category II** Registered Barrel Racing  
Registered Pole Bending  
Registered Cow Pony Race  
Registered Stake Race  
Registered Team Penning
    - c. **Category III** Registered Reining  
Registered Western Riding  
Registered Working Cow Horse  
Registered Trail  
Registered Utility Driving
    - d. **Category IV** Registered Working Hunter  
Registered Hunter Hack  
Registered Jumping
    - e. **Category V** Registered Cutting  
Registered Calf Roping  
Registered Team Roping Heading  
Registered Team Roping Heeling  
Registered Steer Stopping
    - f. **Category VI** Registered Hunter Under Saddle  
Registered Pleasure Driving  
Registered Western Pleasure
    - g. **Category VII** Racing

- h. **Category VIII** Registered Yearling Longe Line (this category eligible for ROM only).
- B. **POINTS AWARDED.** All approved performance classes will be awarded points as set out in Rule SC-060.
- C. **Awards.** When the Register of Merit has been earned, an appropriate award will be mailed to the recorded owner of said horse.

### SC-055. CLASSIFICATION OF SHOWS

- A. **NUMBER OF ENTRIES.** Shows shall be classified according to the number of entries in approved classes limited to Paint Horses. This includes halter and performance classes only and shall not apply to color classes. Each group in a group class will count as one entry.
- \***Class A.**—Shows with 150 or more entries.  
**Class B.**—Shows with 90 through 149 entries.  
**Class C.**—Shows with 51 through 89 entries.  
**Class D.**—Shows with 50 or less entries.
- \* A minimum of 40 individual horses must be exhibited.

### SC-060. POINTS

- A. **QUALIFYING AGE.** Points shall be awarded only to qualifying 2-year-old and older horses entered and exhibited in approved APHA shows or contests. **Exception:** Points shall be awarded to yearlings in their respective halter classes with a maximum of 10 halter points to qualify for a Championship, 15 halter points toward a Supreme Championship or Superior Champion, and 25 halter points towards a Superior or Superior All-Around, except that all points earned prior to January 1, 1987 shall apply to the above awards. Points shall also be awarded to yearlings in longe line per Rule SC-191.A.

1. **Point Tabulation.** Points given for show and contest classes:

No. Horses in Class	Placings					
	1st	2nd	3rd	4th	5th	6th
3-5	1					
6-8	2	1				
9-11	3	2	1			
12-14	4	3	2	1		
15-17	5	4	3	2	1	
18 & Over	6	5	4	3	2	1

2. **Combined Age Classes.** In figuring the points for a class of combined age groups, only the horses one year of age or older will be counted in the "number horses in class" column on scale above. However, all registered horses in the class, regardless of age, will count toward the classification of the show as set forth in Rule SC-055.A.
3. **Less Than Three Horses.** No class of less than three horses shall receive points, but all classes, regardless of number shall be judged.
4. **Number of Horses Actually Shown.** In any contest, points shall be awarded on the basis of the total number of horses actually judged in each contest whether or not an elimina-

tion is held. **EXAMPLE:** If 100 horses were entered and exhibited in an elimination, points would be based on that number.

## **SC-065. GRAND & RESERVE CHAMPIONS**

- A. **GRAND CHAMPION POINTS AWARDED.** The Grand Champion of each sex division will receive at least one point more than any other horse 1-year-old or older in its sex division, provided at least three 1-year-old and older entries were exhibited in that sex division. If necessary, additional points will be added to the points the Grand Champion won in its age class to give it this total. **The Grand Champion will always receive a minimum total of two points in any show where at least six horses have competed in that sex division which are of point-earning age. See Rule SC-175.K.4.**
1. **Example.** If the Grand Champion Stallion received three points for being first in its class, and the first place stallion in another class also received three points, then the Grand Champion Stallion will be given one point more so that it will have a point more than any other horse in its sex division.
  2. **Or.** If the Grand Champion Stallion received three points for being first in its class, and no other stallion received more than two points in its class, then no additional points will be awarded to the Grand Champion Stallion
  3. **Or.** The 2-year-old class has two entries, the 3-year-old class has one entry and the aged class has three entries, then if the winner of the aged class is also the Grand Champion; he received one point for winning the class and another point for being Grand Champion in order that he shall have a minimum total of two points, in any show where at least six horses of point-earning age have competed.
- B. **RESERVE CHAMPION POINTS AWARDED.** The Reserve Champion of each sex division will receive as many points as any horse 1-year-old or older in its sex division, except the Grand Champion. If necessary, additional points will be added to the points the Reserve Champion won in its age class to give it this total. **The Reserve Champion will always receive a minimum total of one point in any show where at least six horses have competed in that sex division which are of point-earning age. See Rule SC-175.K.4.**
1. **Example.** If the Reserve Champion Stallion received two points in its class and another stallion which was not the Grand Champion Stallion received three points in its class, then the Reserve Champion Stallion will be given one point more so that it will have as many points as any other horse in its sex division except the Grand Champion Stallion.
  2. **Or.** If the Reserve Champion Stallion received two points in its class and no other stallion, except the Grand Champion Stallion, received more than two points, then no additional points will be awarded to the Reserve Champion Stallion.

3. **Or.** The 2-year-old class has two entries, the 3-year-old class has two entries and the aged class has two entries, and the aged class winner is also the Reserve Champion; he receives one point in order that he has a minimum total of one point, in any show where at least six horses of point-earning age having competed.

### **SC-070. EXHIBITOR CONDUCT**

- A. **REQUESTING JUDGE'S OPINION.** An exhibitor may make a request through the ring steward or other show official for a judge's opinion concerning an exhibitor's horse which can be stated in the presence of a ring steward or other show official at any time; however, at no time will fraternization between the exhibitor and the judge be permitted during the show.
- B. **UNSPORTSMANLIKE CONDUCT.** When an exhibitor, owner or trainer is guilty of unsportsmanlike conduct, such person is subject to disciplinary action by the APHA, including but not limited to, fines or suspension. See Rules GR-060.C., GR-070.A. and GR-070.D.

### **SC-075. INHUMANE TREATMENT**

- A. **INHUMANE MANNER OF TREATMENT.** No person on show grounds, including but not limited to, barns, stalls, parking area and show arena, may treat a horse in an inhumane manner, which includes, but is not limited to:
1. Placing an object in a horse's mouth so as to cause undue discomfort or distress;
  2. Tying a horse in a manner as to cause undue discomfort or distress in a stall, trailer or when longing or riding;
  3. Letting blood from a horse;
  4. Use of inhumane training techniques or methods; poling or striking horses legs with objects (i.e. tack poles, jump poles, etc.);
  5. Use of inhumane equipment, including, but not limited to, saw tooth bits, hock hobbles, tack collars or tack hackamores;
  6. Any item or appliance that restricts the movement or circulation of the tail; or,
  7. Intentional inhumane treatment which results in bleeding.
- B. **IMMEDIATE REPORT BY MANAGEMENT.** Upon discovery by any show official of inhumane treatment, show management shall immediately report the matter to the Association.
- C. **ACCEPTED STANDARD OF CONDUCT MEASUREMENT.** The standard by which conduct or treatment will be measured is that which a reasonable person, informed and experienced in generally accepted equine training and exhibition procedures, would determine to be cruel, abusive and inhumane. See Rules GR-060.C., GR-070.A. and GR-070.D.

### **SC-080. PROHIBITED PROCEDURES**

- A. **PROCEDURES AFFECTING PERFORMANCE OR**

**NATURAL CONFORMATION.** Any Surgical procedure, injection or oral administration of any foreign substance or drug which could affect the horse's performance or alter its natural conformation or appearance is prohibited, except for those surgical procedures performed for the sole purpose of protecting the health of the horse. Upon discovery of the existence of prohibited surgery, show management should immediately report the matter to the Association.

1. **Ineligibility of Participation in APHA Approved Shows.** Such surgical procedure or foreign substance injection shall be grounds for the Executive Committee or any appropriate committee of the Association to bar the horse from future participation in APHA approved events or shows for such period of time as determined appropriate, and, upon request, the owner shall deliver the horse's registration certificate to the Association for such ineligibility to be prominently marked on the face of the registration certificate. Although ownership of the horse may thereafter be transferred to another party, the transfer of ownership will not dissolve or shorten the term of ineligibility. See Disciplinary Procedures Rule GR-070.
  - a. APHA representatives may examine any registered American Paint Horse for any surgical procedure or injection of any foreign substance or drug which could affect the horse's performance or alter its natural conformation or appearance if entered in any event held in conjunction with an APHA-approved show, whether or not the event is approved by APHA.
2. **Owner and Exhibitor Each Responsible.** The owner/trainer/exhibitor are each responsible for a horse's condition and presumed to know all rules and regulations of the Association, and the penalty provisions of these rules. Such individual's voluntary act in entering, exhibiting or causing to be exhibited a horse in an approved show makes him eligible for disciplinary sanctions, whether or not the owner/trainer/exhibitor had actual knowledge of the surgery, or directly authorized the surgical procedure or injection of foreign substance. Purchase and subsequent exhibition of a horse with such condition in an approved show makes an individual responsible under this rule.
3. **Show Management or Association Examination Request.** Every owner/trainer/exhibitor shall upon request of show management or Association representative, permit examination of a horse for determination of the presence of prohibited surgery and/or foreign substance injection and refusal of request shall immediately be reported to the Association.
4. **Executive Secretary may Temporarily Suspend Pending Final Hearing.** Pending final hearing by the Executive Committee or such other appropriate hearing committee, the Executive Secretary may, by giving written notice of his action to the owner of record at his current address as shown on Association records, temporarily suspend a horse from further participation in an APHA

- approved event or show and request the return of its registration certificate if preliminary examination indicates a violation of this rule.
5. The definition of exhibitor as provided in the Association's rules pertains also to this rule.
  6. Surgical procedures cannot be performed after January 1, 1987.

## SC-085. DRUGS AND MEDICATIONS

- A. **FORBIDDEN SUBSTANCES.** A horse shall not be shown in any class at a show approved by the APHA or event held in conjunction with an APHA-approved show, whether or not the event is approved by APHA, if the animal has been administered in any manner a forbidden substance. A forbidden substance is defined as any stimulant, depressant, tranquilizer or sedative which could affect the performance of the horse (stimulant and depressants are defined as substances which stimulate or depress the cardiovascular, respiratory or central nervous system). Also forbidden is any substance, regardless of how harmless or innocuous it might be, which might interfere with the detection or quantitation of any substance defined above. In the event any forbidden substance is administered to any horse for any reason, the owner and/or trainer should withdraw the horse from competition until the drug is no longer present in the plasma or urine.
- B. **PERMITTED SUBSTANCES.** The following *nine* drugs or medications are permitted. Administration of these drugs or medications does not require that the horse be withdrawn or kept out of competition. (*Exception: does not apply if prohibited by government regulations.*)
1. Phenylbutazone
  2. Flunixin
  3. Ketoprofen
  4. Meclofenamic Acid
  5. Naproxen
  6. Acetazolamide
    - a. May only be administered to horses documented through DNA testing to be Positive (N/H or H/H) for HYPP (Hyperkalemic Periodic Paralysis).
  7. Lidocaine/Meplvicaine
    - a. When administered within 24 hours of showing, may only be used under actual observation of event management (or designated representative) and/or the official show veterinarian, either of which must sign the medication report form, to aid in the surgical repair of minor skin lacerations which, by their very nature, would not prevent the horse from competing following surgery. A medication report form must be filed with show management as required in section C. below.
  8. *Furosemide or Lasix, when used, must be administered intravenously at least four (4) hours prior to competition.*
  9. *Isoxsuprine. No part of a dose should be administered during the four (4) hours prior to competing. Any medicated*

*feed should be consumed and/or removed at least four (4) hours prior to competition.*

**C. CONDITIONALLY PERMITTED SUBSTANCES.** In addition to those drugs listed in section B., Therapeutic Medications (those drugs listed in the *ARCI's Uniform Classification Guidelines for Foreign Substances, February 1995 Revised Edition* regulations-class 4 and 5) given for the legitimate treatment of illness or injury are permitted if ALL of the following conditions are met:

1. Filing of a completed medication report (available from APHA or show management) with show management before exhibiting the horse. The medication report must contain the following information:
  - a. Diagnosis of illness/injury, reason for administration, and name of administering and/or prescribing American Association of Equine Practitioners (AAEP) veterinarian.
  - b. Signature of veterinarian or person administering the medication. If prescribed by written instructions, a copy must be attached to the medication report.
  - c. Identification of the medicine; the name, amount, strength and mode of administration.
  - d. Date and time of administration.
  - e. Identification of the horse: Name, age, sex, color and entry number.
2. The horse must be withdrawn and kept out of competition for not less than 24 hours after the medication is administered.
3. The medication report must be filed with show management within one hour of administration of the medication or one hour after show management is available, if administration occurs at a time other than during competition hours.
4. The medication report must be signed by show management and the time of receipt recorded on the report.
5. While this report must be filed only if the administered medication will be present in amounts detectable in the blood and/or urine samples at the time of competition/sampling, exhibitors are hereby cautioned it is their responsibility to determine whether or not such medication has had time to clear the horse's system. **IF THERE IS ANY DOUBT, A MEDICATION REPORT SHOULD BE FILED.**

**D. CAUTION AGAINST MEDICINAL PREPARATIONS.** The use of medicinal preparations and tonics of any kind in which the ingredients and quantitative analysis are not specially known is also cautioned against as the use of such may result in a positive analysis of the specimen taken from the horse.

**E. RESPONSIBLE PARTIES.** All owners, trainers and exhibitors are accountable for the condition of any horse which they enter or allow to be entered, in any APHA sponsored or approved event or event held in conjunction with an APHA-approved show, whether or not the event is approved by APHA. Such persons are hereafter referred to

as “**responsible parties**”. By voluntarily entering a horse in an APHA approved or sponsored event or event held in conjunction with an APHA-approved show, whether or not the event is approved by APHA, the responsible parties are presumed to know all rules and regulations of the Association. Based on their accountability for their horse’s condition, all responsible parties are subject to disciplinary action any time a prohibited substance is detected at an APHA approved or sponsored event, regardless of the reason the prohibited substance has been administered, and whether or not the responsible parties had actual knowledge of the administration or presence of the prohibited substance.

- F. **INVOLVED PARTIES.** In addition to the “responsible parties” as that term is used in this rule, any person who administers, aids in the administration, causes to be administered, or conspires in the administration of any prohibited substance shall be subject to disciplinary action. Such persons are hereafter referred to as involved parties.
- G. **TESTING BY APHA OR STATE GOVERNMENT.** All drug testing of APHA approved events will be done under the direction of the APHA unless the show is being conducted in a state whose government has established drug testing procedures. Those shows that are tested by the APHA will be selected at random by the APHA office, however, the show management of any APHA event can request that a show be tested if show management agrees to be responsible for the cost associated with the testing. Any drug testing performed at the request of show management shall be conducted by the APHA staff or its designated representative.
- H. **LABORATORY INTEGRITY.** It shall be presumed that the sample of urine, saliva, blood or other substance tested by the laboratory to which it was sent is the one taken from the horse in question, that its integrity has been preserved, and that all the procedures of the collection and preservation, transfer to the laboratory, analysis of the sample and report received from the laboratory pertaining to the horse in question are presumed to be accurate and correct reflections of the condition of the horse during the show in which the horse was entered. The burden shall be on the responsible or involved parties to rebut the aforesaid presumptions in a hearing conducted by the Association’s Executive Committee or its appointed committee.
- I. **REQUEST FOR SPECIMEN.** A request by the APHA representative or its designee to take a specimen of urine, saliva, blood or other substance for testing shall not be refused by any person. Refusal to comply with such a request shall constitute grounds for immediate disqualification of the horse from further participation in the show and shall also be considered a positive drug test for purposes of this rule. Artificial induction of urination is at the option of the owner/agent.
- J. **COOPERATION WITH APHA REPRESENTATIVE.** Cooperation with the APHA approved veterinarian and/or his agents and/or Association representative shall include, but not be limited to:

1. Taking the animal immediately to the location selected by the appointed veterinarian and/or his agents for testing the horse and present it for testing and presenting the registration certificate or a photocopy for the veterinarian's report.
2. Assist the veterinarian and/or his agent in procuring the sample promptly, including, but not limited to, removing equipment from the horse, leaving it quietly in the stall and avoiding distractions to it. Schooling, lengthy cooling out, bandaging and other delays of this type may be construed as noncooperation.
3. Polite attitude and actions toward the veterinarian and/or his agents and/or Association representative.
4. Failure to cooperate shall be considered a refusal.

K. **HORSES SUBJECT TO EXAMINATION.** Horses in competition at any APHA sponsored or approved event or event held in conjunction with an APHA-approved show, whether or not event is approved by APHA, are subject to examination by a licensed veterinarian or an Association representative who must be approved by the APHA. The examination may include positive identification, physical, saliva, urine, blood tests, or other tests or procedures at the discretion of said licensed veterinarian necessary to effectuate the purposes of this rule. Said veterinarian may examine any or all horses in the class(es) in a show, or any horse entered in any class, whether in competition or not, or any horse scratched or withdrawn or which simply fails to appear for competition, by any other exhibitor within 24 hours prior to the class for which it has been entered. A horse which has been withdrawn from competition may be administered a prohibited substance provided the prohibited substance is declared to show management prior to a requested drug testing.

L. **TEMPORARY SUSPENSION.** At such time as the APHA receives written notification of a positive drug test involving a violation of the rule, all "responsible parties" shall immediately be placed on temporary suspension and denied all privileges of the Association, pending hearing on the matter. The APHA shall mail written notification of this action to the responsible parties and shall also give notification via telephone when possible. Any responsible party will be charged a \$400.00 restitution upon receipt of notice to APHA of a positive drug test.

1. **Post Bond.** Each responsible party may post a \$500.00 bond at which time that party will be allowed to participate in all APHA events and activities until such time as a hearing is held.
2. **Certified Check.** The \$500.00 bond must be in the form of a certified check or money order made payable to the APHA. The bond will become effective at such time as it is received in the APHA office.
3. **Bond Returned.** If it is determined after the hearing that there has been no violation of this rule, the \$500.00 bond will be returned. If it is determined after the hearing that there has been a violation of this rule, the \$500.00 bond will be automatically forfeited to the APHA drug testing fund. This bond forfeiture is in addition to any other penal-

ties or disciplinary action that may be taken against the responsible or involved parties.

- M. **HORSE SUBJECT TO PENALTIES.** The horse involved, as well as the responsible or involved parties, may be subject to, but not limited to, the following penalties where appropriate.
1. **Barred.** Barred from competition.
  2. **Forfeiture.** Forfeit awards, or monies, or points or placings, thereby moving up horses placing behind the disqualified horses and possible redistribution of awards, or monies, or points, or placings.
  3. **Certificate Relinquishment.** Relinquishment of the horse's registration certificate to the Association for a specific period of time. Although ownership of such horse may, thereafter, be transferred to another party, the transfer of ownership will not dissolve or shorten the terms of disciplinary action.
  4. **Penalties or fines.**
  5. **Suspension.**

### SC-090. SHOW APPROVAL

- A. **APPLICATION FORMS.** Any organization, club or individual may request their show or contest and the results be approved by APHA. Application forms must be obtained from the APHA.
- B. **SELECTION OF JUDGES.** *Judges must be selected from the current approved list of the American Paint Horse Association effective January 1 of the current year.*
1. *Request For Judges List. Upon request, the office of the Executive Secretary of the APHA will furnish a list of qualified and approved judges to organizations or persons sponsoring shows or contests.*
- C. **FORM POSTMARKED DATE.** An application form(s) shall be postmarked, postal meters are not acceptable, to the APHA at least ninety (90) days prior to the show or contest entry deadline or show date, whichever comes first. Any application mailed from outside the continental U.S. must be postmarked one hundred (100) days prior to the show or contest entry deadline or show date, whichever comes first. The application(s) must be accompanied by a **non-refundable** twenty-five dollar (\$25) fee, or fifty dollar (\$50) **non-refundable** non-member fee, per judge per show application fee.
- D. **FORM POSTMARKED LATE PENALTIES.**
1. **Postmarked Less than Ninety (90) Days.** Show applications postmarked less than ninety (90) days prior to the show or contest entry deadline or show date, whichever comes first, may be approved with a late penalty of \$75 per judge per show application fee, non-refundable. Late fee is in addition to \$25 application fee, \$50 non-member.
  2. **Postmarked Less Than Sixty (60) Days.** Show applications postmarked less than sixty (60) days prior to the show or contest entry deadline or show date, whichever comes first, may be approved with a late penalty of one hundred and fifty dollars (\$150) per judge per show application fee,

non-refundable.

3. **Postmarked Less Than Thirty (30) Days.** Show applications will not be approved if postmarked, no postal meters accepted, less than thirty (30) days prior to the show or contest entry deadline or show date.
- E. **CLASS LIST SUBMISSION.** Approval of a show will not be granted until a show bill or premium list in scheduled order and date for such show is received by the APHA. Once the show bill or premium list is submitted, the list of classes can be amended up to 30 days prior to show by written notification to APHA. See Rule SC-120.
- F. **DENYING OR RESTRICTING ENTRIES.** Any show that denies or restricts entries in any one of the events listed in SC-175, SC-180 or SC-190 will not have their show results approved.
- G. **SHOW APPROVAL NOTIFICATION.** Show or contest officials will be notified by the APHA if their show or contest is approved or what factor(s) need to be rectified so that the show or contest may be approved. If a certain class is not approved, it may not prohibit the approval of the remaining classes.
- H. **SHOW WEEK-END APPROVAL.** Show applications are approved based upon the date of the week. An APHA-approved show having been held the previous year is considered an established show and has priority to reserve identical days per calendar week for the current year until terminated by APHA.
- I. **MILEAGE BETWEEN SAME SHOW DATE SHOWS.** A show may be approved on the same date as another APHA approved show if the two are not located within 250 highway miles (402.336 km) of each other, with the exception of state, regional and county fairs, and major livestock shows which may be on the same date as another approved show despite proximity. The last sponsor of any individual show has the right to sponsor the show in the following year, provided their application complies with SC-090.C.& J.
- J. **PRIORITY OF SHOW DATES.** Show dates are not the property of individuals or clubs. In the event the previous sponsor does not obtain approval for the show date, then the regional or state club has first priority on the date. A show not approved or held the prior year is considered a new show. Additionally, a show which changes sponsoring body (the individual or regional club financially responsible for holding the show) or the show name or changes location more than 250 miles (402.336km) is considered a new show without priority for days.
  1. **Mileage Waiver.** If all affected show managements agree to waive Rule SC-090.I., then and in that event, approval may be granted.
  2. **Mileage Limitation, U.S. and Canada.** The mileage limitation between shows does apply to shows between the United States and Canada.
  3. **Cancellation of Show Dates.** Sponsors of shows who cancel their dates must notify the APHA Performance

Department **IMMEDIATELY** so the date(s) can be made available to another sponsor.

4. **Show Approvals on APHA Sponsored Show Dates.** Single judged shows will be approved by the APHA during the same dates that an APHA sponsored show is held. Paint-O-Ramas may be approved during APHA sponsored shows with a 600 mile (965.606km) restriction.
5. **Traditional Holiday Weekends.** All APHA regional clubs who have received approval from the Executive Committee to host shows on traditional holiday weekends on a permanent basis will continue to receive approval under the following requirements:
  - a. This policy applies only to approved APHA regional clubs.
  - b. The mileage restriction will apply to new shows requesting the same dates on which the traditional holiday weekend falls.
  - c. The mileage restrictions would not apply to shows established on the two numbered weekends that are affected by the reserved traditional holiday assignment(s) and calendar shifts.
  - d. The show must be held in the same state.
  - e. The show must be held each year. If the show is not held, the club forfeits that traditional holiday weekend.
  - f. New traditional holiday weekends will not be given after January 1, 1986.
  - g. This rule is retroactive to January 1, 1985.
- K. **NAME OF SHOW.** All shows or contests approved by the APHA shall be named, advertised, listed and otherwise referred to as a Paint Horse Show. The name of the show or contest may not include words referring to another breed, breed association and/or type of horse. **The words "Champion" or "Championship" are reserved for shows sponsored by the APHA.** Nor shall any individual or organization use the words, **World, National, or International** in connection with any sale, futurity, or other activity sponsored by such individual or organization which states or infers that the same is approved by the APHA without the written permission of APHA.
- L. **APPROVAL DENIED OR WITHHELD.** Withholding approval of regional club sponsored shows will be in accordance with Article IX, Section 3.B.1. & Section 6. and SC-090.M.
- M. **APHA RULES TO BE USED.** The rules as set out in this APHA Rule Book shall be used at all approved shows, unless otherwise approved by the Executive Secretary of the APHA. Failure to follow the APHA Rule Book in conducting the show may result in future approval of shows being denied and/or possible disciplinary action. The Executive Committee would decide such cases.
- N. **FAILURE TO PAY SERVICES.** The sponsor or sponsors of any APHA- approved show which fails to pay for any services rendered by a third party (i.e. judges fees, cattle fees, facilities, or to pay premium money to exhibitors, etc.) in connection

with the holding of an approved show will be denied APHA approval for future shows until all fees are paid.

- O. **TITLES RESERVED.** The following titles shall be reserved for exclusive use by APHA: APHA WORLD CHAMPIONSHIP SHOW, APHA WORLD CHAMPION HORSE and APHA RESERVE WORLD CHAMPION HORSE; APHA INTERNATIONAL CHAMPIONSHIP SHOW, APHA INTERNATIONAL CHAMPION HORSE and APHA RESERVE INTERNATIONAL CHAMPION HORSE; AjPHA YOUTH WORLD SHOW, AjPHA WORLD CHAMPION HORSE, and AjPHA RESERVE WORLD CHAMPION HORSE and APHA NATIONAL CHAMPIONSHIP SHOW, APHA NATIONAL CHAMPION HORSE and APHA RESERVE NATIONAL CHAMPION HORSE.

### SC-095. MINIMUM REQUIREMENTS FOR SHOWS

- A. **APPROVAL.** For a show to be approved, the following classes must be offered.
1. **Stallions.** Four Halter classes for stallions.
    - a. Yearlings.
    - b. Two-Year-Olds.
    - c. Three-Year-Olds.
    - d. Four-Year-Olds and older.
  2. **Mares.** Four halter classes for mares.
    - a. Yearlings.
    - b. Two-Year-Olds.
    - c. Three-Year-Olds.
    - d. Four-Year-Olds and older.
  3. **Geldings.** Two halter classes for geldings.
    - a. Yearlings and Two-Year-Olds.
    - b. Three-Year-Olds and older.
  4. **Performance.** Four performance contests. Rule SC-190.A.
- B. **AGE DIVISIONS.** Age divisions may be added for halter and performance events if entries justify.
- C. **NOTICE:** In special cases the Executive Committee of the Association may approve single classes for APHA points. Such approved classes must use an approved APHA judge and use the show rules as set forth in this Rule Book.

### SC-096. SPECIAL APHA PAINT EVENTS

- A. Organizations or individuals wishing to stage or sponsor Special APHA Paint Events (i.e. team pennings, cuttings, reinings, team ropings, etc.) must obtain approval of the APHA if the results of such events are to be recognized and points are to be awarded to the horses which place sufficiently high in that event. Approval does not carry over from year to year, but must be obtained for each individual event. All rules and regulations and fees pertaining to APHA shows will be followed in Special APHA Paint Events.

#### **B. WORKING RANCH HORSE COMPETITION.**

1. **GENERAL RULES.** *This special event is designed to pro-*

mote and enhance the pleasure of riding a versatile working American Paint ranch horse. The intent of this competition is to show the overall ability of the horse to perform skills necessary to those of the all around ranch horse. It is not the intent of these rules for this to be considered a horse show class. These competitions are time consuming and must be given adequate time and space to maximize the full extent of each entry's abilities. When possible, it is encouraged that this competition be held outside and in an open space which simulates ranch terrain. The use of natural obstacles is also encouraged.

- a. Any regular registry or breeding stock American Paint Horse is eligible to compete in their respective divisions.
  - b. No horses less than three years of age are eligible to compete.
  - c. No hoof polish.
  - d. No braided or banded manes or tail extensions.
  - e. Trimming inside ears is discouraged.
  - f. Trimming of bridle path, fetlocks or excessive long facial hair is allowed.
2. **POINTS.** APHA Points will be awarded based on the final placing of all eligible horses. To be eligible for points for the Working Ranch Horse Competition, one rider/one horse must enter all four classes. Credits will be applied per class according to the placing received based on the number of horses competing in that particular class. Horses competing and placing in the top seven will be awarded one credit for each horse or contestant placing below them, plus one additional credit, not to exceed seven credits for first place. Credits received in each class will be totaled. After totaling credits, the horse receiving the highest number of credits will be placed first in the Working Ranch Horse Competition. The horse receiving the second highest credits will be placed second in the Working Ranch Horse Competition and so on. APHA points will be awarded in the Working Ranch Horse Competition according to the existing point schedule (Refer to Rule SC-060).
- a. Ties in the final placing for the Working Ranch Horse Competition will be broken by the highest placing horse in the Working Stock Horse Class. **All exhibitors should be placed in the Working Stock Horse Class in order to break ties.**
3. **AWARDS AND RECOGNITION:**
- a. Current APHA point system will apply.
  - b. Working ranch horse points will be awarded based on the number of horses meeting all requirements outlined.
4. **CLASSES.** Following is a list of four required classes with descriptions and guidelines for judging:
- a. *Stock Horse Pleasure:* This class serves to measure the ability of the horse to be functional and a pleasure to ride while being used as a means of conveyance from one stock horse task to another. This horse should be well-

*broke, relaxed, quiet, soft and cadenced at all gaits. The horse should be ridden on a relatively loose rein with light contact and without requiring undue restraint. The horse should be responsive to the rider and make all required transitions smoothly, timely and correctly.*

1. *Horses shall be shown individually at the walk, trot, and lope in both directions. The trot and lope will be extended in one direction only.*
2. *The class may be conducted inside or outside of an arena. Markers shall be setup to designate gait changes or called on the public address system. If the class is held inside of an arena, the pleasure course shall be setup to make approximately one circle of the arena in each direction. If open terrain is available, it is encouraged that the class be held outside an arena. The order of gaits shall be: walk, trot, extended trot, lope, stop and reverse, walk, lope, extended lope, trot, stop and back. The pattern may be started either in the left or right direction.*
3. *The extended trot may be ridden with the rider either posting or standing in the stirrups to the front of the saddle. Holding the saddle horn is permissible, at this gait, as might be done in open terrain. When transitioning from the extended trot to the lope, it is permissible to take the horse back a bit (collecting) before loping.*
4. *Scoring Stock Horse Pleasure. Each gait, including transitions, will be scored from 1-10. There will be 5 scores in each direction for a total of 10 scores and a maximum of 100 points for each horse's work. A Ring Steward shall assist the judge by serving as a scribe and recording the score after each of the 10 transactions. The scores should be totaled after each run and the score should be announced on the public address system, if possible. Score sheets shall be posted after each class to allow riders to evaluate their performance.*
  - a. *The scoring guide for each maneuver, including transitions, is as follows:*
    - Score of 1-4 Points**—*Major faults such as wrong lead, broken gait, lack of control, failure to perform requested gait.*
    - Score of 5-7 Points**—*Average quality of movement with some or no faults.*
    - Score of 8-10 Points**—*High quality mover that is functionally correct in all gaits, well mannered and responsive, soft and cadenced in all gaits.*
  - b. *Stock Horse Versatility Class. The versatility class, as the name implies, test the horse's ability to cope with many situations encountered in everyday ranch work. The horse is ridden through a pattern of obstacles and is judged on his ability to negotiate them correctly. It*

*is recommended that six to ten obstacles be used in this event. Obstacles may be placed in any order and location, however, obstacles should nearly approximate those found on the ranch during the course of everyday ranch work. It is required that the horse be asked to trot and lope during the event course. Show committees have the option of setting up the versatility course to best fit their arena conditions. An outdoor course is recommended if appropriate terrain is available. In addition, there is a time factor involved.*

- 1. Versatility Class Obstacles. Following is a list of obstacles from which selections can be made, but not limited to:*

*Back through, in or around selected areas*

*Carry sack of feed*

*Drag obstacle with rope through obstacle*

*Ground Tie*

*Hobble*

*Jump over obstacle*

*Lead at trot*

*Load in trailer*

*Open-close gate*

*Open gate on foot*

*Pick up feet*

*Put on slicker/coat*

*Rope dummy steer head*

*Side pass maneuver*

*Stand to mount*

*Stand to saddle*

*Step in & out of obstacle*

*Swing rope*

*Trot or lope over posts*

*Walk over bridge*

*Walk through brush*

*Walk over water obstacle*

- 2. Scoring Stock Horse Versatility Class. Each obstacle shall be scored from one to ten, with ten being ideal. The rider has the option of eliminating any obstacle and receiving a zero for the missed obstacle. In addition, credit shall be given to the horse that negotiates obstacles briskly and without undue hesitation. A judge may ask a horse to pass on an obstacle after three refusals.*

- c. Working Stock Horse Class. A model stock horse must also be a cow horse and this class has been designed to demonstrate and measure the horse's ability. Holding the saddle horn is permitted in this class. There will be a 3 1/2 minute time per horse to perform the entire work which will consist of the following three parts.*

- 1. Boxing the Cow. The rider shall ride into the arena and face the cattle entry gate. The rider shall signal for their cow to be turned into the arena. Upon entry into the arena, the cow shall be controlled on the entry end of the arena for a sufficient amount*

- of time to demonstrate the horse's ability to box "hold" the cow. If the cow does not immediately challenge the horse, the rider shall aggressively move in on the cow to demonstrate his horse's ability to drive and block the cow on the entry fence.*
2. *Fence Work. After the cow has been controlled on the end of the arena, the rider shall deliberately release the cow and drive it down the side of the arena. The cow should be past the half-way mark of the arena. All turns down the side shall be completed before reaching the end fence.*
  3. *Optional Roping or Circling—For the third part of this class, the rider has the option to either rope and stop the cow or to take the cow to the middle of the arena and circle it at least once in each direction. A rider may circle or rope the cow, but cannot combine the two together for this portion of the class.*
    - a. *To rope the cow, the rider must be carrying a rope when the class starts. The rider may pull up after the fence work, take down the rope, and proceed to rope and stop the cow.*
    - b. *The rider may only throw two loops. A "no catch" does not necessarily mean a score of zero for this portion of the class. A horse may be given credit for rating and tracking, but should not be scored higher than a horse that has also demonstrated the ability to stop and hold a cow.*
  4. *Scoring Working Stock horse Class. Scoring for the working stock horse class shall be 20 points for each of the three parts of the class with a total of 60 points for the entire class.*
    - a. *Scoring for Part One—Boxing (maximum of twenty points)*  
*Credit: + Expression by the horse and making moves with little rider assistance*  
*+ Holding and controlling the cow*  
*+ Amount of work actually done and the degree of difficulty of the work*  
*Deductions: Missing cow badly on turns*  
*- Horse having to be handled excessively*  
*- Letting cow escape to start rundown instead of being held, released, and driven down the fence.*
    - b. *Scoring for Part Two – Fence Work (Maximum of twenty points)*  
*Credit: + First run at least 1/2 length of arena*  
*+ Turns that are right on the cow*  
*+ Controlling a difficult cow*  
*Deductions:—Making the first run less than 1/2 length of arena*  
*- Using end fences to help turn cow*

- Going around the end of arena to get a turn

- Sliding by cow by more than a nose length on turns.

c. *Scoring for Part Three – Optional circling or roping (Maximum of twenty points)*

*Circling*

*Credit: + Getting up on cow close enough to control the circles*

*+ Acknowledging the cow during circling and working willingly*

*Deductions:–Lack of control in circles due to distance from cow*

*- Not acknowledging the cow or simply lack of horse's ability*

*Roping*

*Credit: + Rating and following cow to allow roper the optimum position to rope*

*+ Stopping hard and staying on the ground during the jerk*

*Deductions:–Not tracking, not rating and not catching up to the cow*

*- Poor stop*

*- Being pulled by the cow*

d. *Stock Horse Reining Class. This class measures the ability of the stock horse to perform many basic handling maneuvers. The horse should guide willingly without undue resistance. There are two recognized patterns. Rules for scoring the reining portion are defined in Rule SC-260 of the APHA Rule Book. See page 297 for legend for the following patterns (diagrams).*

## Stock Horse Reining Pattern #1

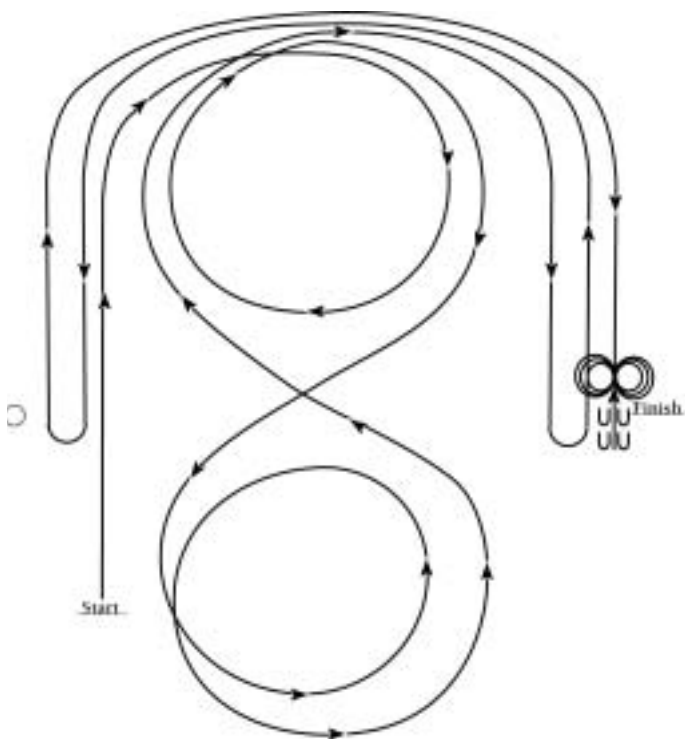

1. Beginning and staying at least twenty feet (6 m) from the walls or fence, lope straight up the left side of the arena, circle the top end of the arena and complete two large fast circles to the right. Change leads at the center of the arena.
2. Complete two large fast circles to the left. Change leads at the center of the arena.
3. Begin a large fast circle to the right but do not close this circle. Run straight down the right side of the arena past the center marker and do a left rollback – no hesitation.
4. Continue around previous circle but do not close this circle. Run down the left side of the arena past the center marker and do a right rollback at least twenty feet (6 m) from the wall or fence – no hesitation.
5. Continue back around previous circle but do not close this circle. Run down the right side of the arena past the center marker and do a sliding stop at least twenty feet (6 m) from the wall or fence. Back up at least ten feet (3 m).
6. Complete three spins to the right. Hesitate.
7. Complete three spins to the left. Hesitate to demonstrate completion of the pattern.

## Stock Horse Reining Pattern #2

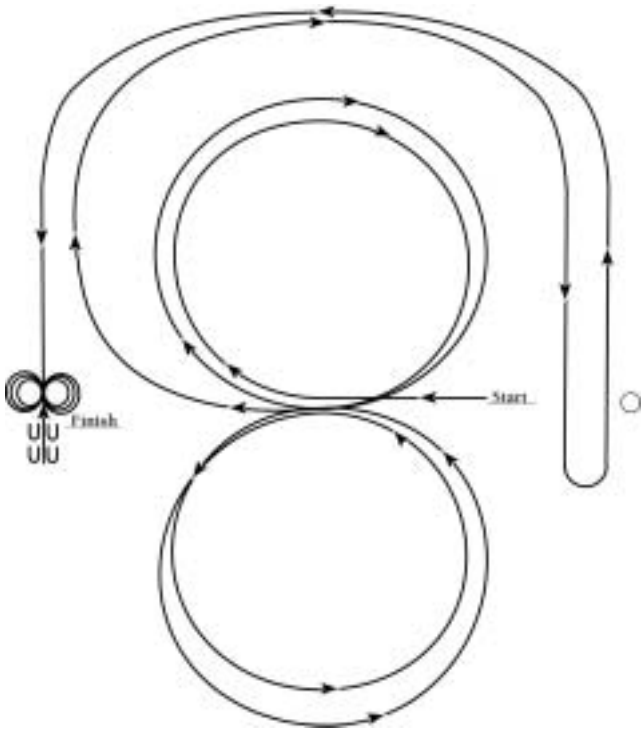

Horses may walk or trot to the center of the arena. Beginning at the center of the arena facing the left wall or fence.

1. Beginning on the right lead, complete two large fast circles to the right. Change leads at the center of the arena.
2. Complete two large fast circles to the left. Change leads at the center of the arena.
3. Begin a large fast circle to the right but do not close this circle. Run straight down the right side of the arena past the center marker and do a left rollback at least twenty feet (6 m) from the wall or fence – no hesitation.
4. Continue back around the previous circle but do not close this circle. Run down the left side of the arena past the center marker and do a sliding stop at least twenty feet (6 m) from the wall or fence. Back up at least ten feet (3 m).
5. Complete three spins to the right. Hesitate.
6. Complete three spins to the left. Hesitate to demonstrate completion of the pattern.

**TYPES OF SHOWS**  
**SC-100. SINGLE-JUDGE SHOWS**

- A. **SINGLE JUDGE SHOW.** A single judge show is limited to one judge in the arena at any given time and held on one or more days.

**SC-105. MULTIPLE-JUDGE SHOWS**

- A. Multiple-Judge shows are two-judge shows, Paint-O-Ramas or Zone-O-Ramas and are limited to APHA approved shows in which two or more judges are in the arena judging independently at one time on one or more consecutive days.
1. Only show applications deviating from Rules shall be reviewed by the APHA Executive Committee.
  2. Multiple-judge shows must be sponsored and operated by an official APHA Regional Club.
    - a. **EXCEPTION 1. Two-Judge Shows.** Each regional club and each recognized state, regional and county fair, and major livestock shows may hold a two-judge only. (See Rule SC-090.I.)
    - b. **EXCEPTION 2. Zone-O-Ramas.** See Zone-O-Ramas, SC-105.B.3.
  3. Multiple-judged shows must have each judge work independently. **There shall be no consultation or visiting between judges during the actual judging.** Show management must provide a competent scribe for any judge if he or she requests one when signing a contract.
  4. The results of the Grand and Reserve Champion classes will not be announced until all judges for that day have completed their judging on the respective sex division of the Grand and Reserve Champion classes.
  5. Individual runs for each judge may be made in all timed events. The decision on whether or not to require individual runs for each judge is to be made by the show manager.
- B. **MULTIPLE-JUDGE SHOWS.**
1. **TWO-JUDGE SHOWS.**
    - a. A two-judge show is limited to two (2) judges in the arena at any given time and held on one or more consecutive days.
    - b. Such shows cannot be held on contiguous dates and within 250 highway miles (402.336km) of any other APHA-approved shows. Exception: Youth/Amateur multi-judged shows.
  2. **PAINT-O-RAMAS.**
    - a. Paint-O-Ramas are limited to two (2), three (3), or four (4) judges on one or more consecutive days, not to exceed four (4) judges in the arena at any given time. When back to back Paint-O-Ramas are being held, one show must be concluded before the second Paint-O-Rama can begin.
      1. Exception: Halter and Longe Line classes ONLY, if scheduled as concluding classes of the first

Paint-O-Rama and the beginning class of the second Paint-O-Rama, may be approved on the same date and judged simultaneously not to exceed eight (8) judges in the arena at any given time; and/or,

2. Exception: Trail and Showmanship classes ONLY, if scheduled as concluding classes of the first Paint-O-Rama and beginning classes of the second Paint-O-Rama, may be approved on the same date and judged in split arenas with separate courses/ patterns not to exceed eight (8) judges (four (4) per course/ pattern) in the arena at any given time.
- b. The number and location of Paint-O-Ramas which each APHA Regional Club is entitled to have shall be determined by the following:
    1. Any APHA Regional Club whose territory encompasses one or more entire state(s) or province(s) may have a maximum of two (2) Paint-O-Ramas per year. All other APHA Regional Clubs are entitled to one Paint-O-Rama per year.
    2. No APHA Regional Club may sell or assign its Paint-O-Rama sponsorship to any other club.
    3. No APHA Regional Club may host a Paint-O-Rama outside its state(s) or province(s).
3. **ZONE-O-RAMAS.**
- a. Each zone is eligible for one Zone-O-Rama per year.
  - b. Each Zone-O-Rama is limited to a maximum of six (6) judges on two or more consecutive days.
  - c. Each Zone-O-Rama show must be coordinated and sponsored by a Zone Coordinating Committee consisting of representatives from each state and/or Regional club of the zone.
  - d. The Zone Coordinating Committee would be organized at a meeting consisting of an equal number of representatives from each state that wished to participate from that zone. Three per state is suggested. It is not mandatory for a state to participate.
  - e. The organizational meeting would elect officers and decide the number and manner of future representatives as well as the preliminary Zone-O-Rama business.

f. APHA Zone Maps - US and Canada.

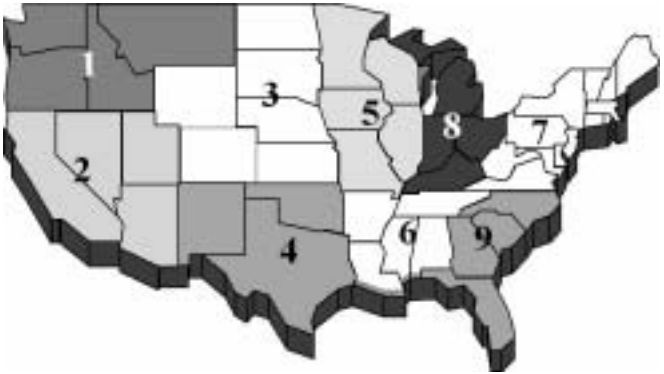

\* plus Alaska

g. **Zone States, Countries and Provinces.** States, Countries and Provinces included in each zone are as follows:

**Zone 1.** Idaho, Montana, Oregon and Washington.

**Zone 2.** Arizona, California, Hawaii, Nevada and Utah.

**Zone 3.** Colorado, Kansas, Nebraska, North Dakota, South Dakota and Wyoming.

**Zone 4.** New Mexico, Oklahoma and Texas.

**Zone 5.** Illinois, Iowa, Minnesota, Missouri and Wisconsin.

**Zone 6.** Alabama, Arkansas, Louisiana, Mississippi and Tennessee.

**Zone 7.** Connecticut, Delaware, the District of Columbia, Maine, Maryland, Massachusetts, New Hampshire, New Jersey, New York, Pennsylvania, Rhode Island, Vermont, Virginia and West Virginia.

**Zone 8.** Indiana, Kentucky, Michigan and Ohio.

**Zone 9.** Caribbean Islands, Florida, Georgia, North Carolina and South Carolina.

**Zone 10.** Alaska, Alberta, British Columbia, Manitoba, North West Territories, Saskatchewan and Yukon.

**Zone 11.** New Brunswick, Newfoundland, Nova Scotia, Ontario, Prince Edward Island and Quebec.

**Zone 12.** All European Countries.

**Zone 13.** All South American Countries and Mexico.

**Zone 14.** Australia, New Caledonia and New Zealand.

### SC-110. SHOW MANAGER

- A. **ELIGIBILITY.** Any reputable person who can furnish proof that he is capable through ability or experience may act in the capacity of show manager.
- B. **PERSON IN CHARGE.** The show manager shall be the person in charge of the Paint Horse division of the show or contest.
- C. **ENTRY BLANKS, PREMIUM LISTS AND CATALOGS.** The show manager shall have the jurisdiction over preparing and mailing all entry blanks, premium lists and catalogs. He shall enforce the arrival and departure times as shown in the premium list or as advertised.
- D. **RESPONSIBILITIES.** The show manager shall at all times extend every effort to satisfy the comfort of the horses, the exhibitors, the spectators and the officials. He shall be held responsible for maintenance of clean and orderly condition throughout the show or contest.
- E. **AUTHORITY.** The show manager shall have the authority to enforce all rules referring to the show or contest. He may excuse any horse or exhibitor from the show or contest prior to or during the judging for the safety of other horses or the spectators or remove an exhibitor for unsportsmanlike conduct.
- F. **SHALL NOT ACCEPT ADDITIONAL ENTRIES.** The show management shall not accept additional entries in a class once competition or judging for that class has begun.
- G. **IDENTICAL CONDITIONS FOR ALL.** He shall make sure all obstacles, barriers, starting lines, markers, etc., are returned to their original position for each contestant so that conditions are identical for all contestants.
- H. **ARENA GATES OPEN OR CLOSED.** The show management shall use his judgment on whether the show arena gates will be open or closed during timed events. EXCEPTION: YP-080.K. His decision shall be based upon the condition and layout of the show arena.
- I. **LINE UP FOR PLACINGS.** The show management must line up in order and announce placings of all contestants one through seven places prior to allowing final contestants to retire from the arena. This includes all classes under all judges.
- J. **RETAIN COPIES OF JUDGE'S CARDS.** At the close of the show or contest, the show management shall retain copies of the original signed judge's placing cards, copy of the show results and entry cards for at least one (1) year from date of show.

### SC-115. SHOW SECRETARY

- A. **ELIGIBILITY.** Any reputable person may act in the capacity of show secretary who can furnish proof that he or she is capable through ability and experience and is familiar with APHA rules.
  - 1. The show secretary may not hold the position of show

manager or ring steward at a show at which he/she serves as show secretary.

2. The show secretary shall be the primary person responsible for verifying exhibitor and horse's eligibility and correctness of show results.
- B. **RESPONSIBILITY.** The responsibility of the show secretary shall be to:
1. Maintain and record both entries and show results. If a horse is disqualified, it is not to be placed, regardless of the number of horses in the class, but counts as an entry in the class.
  2. The show secretary must submit show results to the Association within **fifteen (15) days** of the last date of the show.

### SC-120. PREMIUM LISTS AND PRIZES

- A. **PREMIUM LIST ENTRY FEES.** Premium lists and entry forms should be printed in order to insure uniformity. All shows must abide by the entry fees listed on their premium lists.
- B. **PRIZES OFFERED.** If money prizes are offered, the fixed amount of each prize shall be stated in the premium list. Special prizes do not have to appear on the premium list but it is recommended because it enhances the attractiveness of the show or contest. The show committee is not required to award any existing unwon prizes.
- C. **CONTENT.** The premium list shall contain a list of officers of the show or contest and the names of the Paint Horse officials. The exact location of the show must be specified and the date or dates to be held; also, the closing date of entries and the exact date and starting time, a list of APHA approved classes in the order to be held and the name of the judge for each day. See Rule SC-160.J & K.

### SC-125. SHOW RESULTS

- A. **SUBMISSION OF SHOW RESULTS.** Show results must be submitted in the format specified by the APHA Performance Department accompanied by the original, signed, final judges' card(s). Continuous form computer printed results will be accepted but will not be furnished by APHA. Show management must return completed judges evaluation forms provided in show packet in order for show results to be processed, or any future show approvals will be denied until evaluation forms are completed and returned to the office.
- B. **RETAINING RECORDS.** At the close of the show or contest, the show management shall retain **copies or duplicates of the judge's original, signed, final placing cards**, copy of show results **as received from APHA** and show entry cards for **one (1) year** from date of show.
- C. **SHOW RESULT MAILING OR CANCELLATION DEADLINE.** Failure to mail the completed show result forms or notification of cancellation to the Association within fifteen (15) days of the last scheduled show date may result in future

approval being denied. Shows which are more than thirty (30) days delinquent in filing their results forms are to be listed in the *Paint Horse Journal*.

- D. **PUBLICATION AND CORRECTION OF SHOW RESULTS.** Show results of approved shows and contests will be *listed on the Official Association Website*. A period of one year from the date of the show will be allowed for a correction of show results. After that date, no request for show result correction will be considered. It is the responsibility of the owner of record at the time the horse is exhibited to notify APHA of any possible errors in show results.
- E. **DISCREPANCIES.** Discrepancies between APHA approved show classes and classes actually offered and conducted at the show shall be presented to the Executive Committee for judgment when properly submitted by the contestants or show management.
- F. **SHOW ASSESSMENT FEES. SHOW MANAGEMENT MUST COLLECT TWO DOLLARS (\$2.00) PER HORSE FOR SINGLE, TWO JUDGE AND SPECIALTY SHOWS AND MUST COLLECT THREE DOLLARS (\$3.00) PER HORSE PER SHOW (JUDGE) FOR PAINT-O-RAMAS AND ZONE-O-RAMAS AND FORWARD TO APHA OFFICE IN ORDER FOR SHOW RESULTS TO BE PROCESSED. SEE RULE GR.055.A.**

### SC-130. JUDGES

*For information on requirements for becoming an approved APHA judge, contact the APHA by mail, telephone, or on the internet, using the information on page one of this Rule Book. See Judges Section for rules governing Judges (JU-000).*

### SC-135. RING STEWARD

- A. **QUALIFICATIONS.** A competent ring steward will be required at all approved shows. Any reputable person may act in the capacity of ring steward who can furnish proof that he is capable through ability or experience and is familiar with the APHA rules.
- B. **LARGE CLASSES.** A good ring steward makes the work of the judge much easier by relieving the judge of unnecessary details. If the class is too large, the ring steward will inform the judge of the size of the incoming class so the judge may divide the class if he wishes to do so. By assembling the class promptly, he will be able to keep the judging program on schedule and eliminate long delays between classes.
- C. **HORSES PRESENT OR ABSENT IN CLASS.** The ring steward will notify the judge when all horses are present for each class and call his attention to those horses which are absent. This information will be placed on the record which the steward marks after each class has been judged.
- D. **ASSIST THE JUDGE.** The ring steward(s) must have in mind that they have been selected to help the judge—not advise him. Steward shall carefully refrain from discussing or seeming to discuss the horses or the exhibitors with the judge. Stewards

shall **not** take part, or seem to take part, in any of the judging. When steward is not actively engaged in his duties, steward shall place themselves in such a position so as not to interfere with the judging and the view of the spectators. Steward must not allow the exhibitors to crowd up in the ring or arena and should, at all times, endeavor to keep the possibilities of an accident at a minimum.

- E. **AUTHORITY AND ACTIVITY IN THE RING/ARENA.** The ring steward has charge of the activity in the ring or arena. The ring Steward shall act as mediator between the judge and the exhibitor. The judge should request the steward to move and place horses as he advises. When the ring or arena size is small and the class entries are large, steward should survey the situation and take every precaution to keep the horses moving until the judge is ready for them to be judged. Steward has the authority to ask an exhibitor to remove his/her horse for the safety of other horses or the spectators or remove an exhibitor for unsportsmanlike conduct.
- F. **SIFTING.** It is important that the ring steward be familiar with the procedure of sifting, when the classes are large and the judge requests that he/she line them up for the first sift, the second sift, and so on, until the judge has his class ready.
- G. **ARRANGING CLASS PLACINGS.** The ring steward shall assist in arranging the class winners the same in every class. The public has a right to know how the various horses placed. Example 1st through 7th or 7th through 1st.
- H. **GRAND AND RESERVE JUDGING.** When the judge has completed the judging of halter classes of one sex division, then the steward shall call all first and second place class winners into the ring. Steward shall assemble the first place class winners in one line and the second place class winners in another.

#### SC-140. VETERINARIAN

- A. **LICENSED VETERINARIAN.** Any licensed veterinarian may officiate in the capacity of horse show veterinarian.
- B. **HEALTH REQUIREMENTS.** Health requirements should be outlined in the catalogs and on the entry blanks and enforced by the show management and veterinarian at facilities where required.

#### SHOW AWARDS

##### SC-145. SHOW ALL AROUND AWARD

- A. **SCORING FOR SHOW ALL AROUND.** It is not mandatory for an **All-Around** award to be made at an approved show; however, if such an award is designated the following scoring system shall be used to determine the winner:
  - 1. **Grand & Reserve Champion Points.** To be eligible for All-Around honors, a horse must compete in open halter and at least three of categories II through VI as listed in Rule SC-050.A.3 Halter Grand Champions will receive two additional points and Reserve Champions one additional point.

2. **Class Points.** Horses placing in the top six will be given a point for each horse placing below them plus one point not to exceed six points for first place. Points are calculated through sixth place. Example: In a class of six or more horses, the first place horse receives six points; the second place horse gets five points; in a class of four the first place horse receives four points; the second place gets three points; etc.
3. **No Points When Disqualified.** No points are to be awarded to a disqualified horse, regardless of the number in the class; however, when less than six are placed, even though more than six entered the class, points will be awarded on the basis of the number exhibited in the class.
4. **Ties.** All ties must be resolved by rules stated by the show management or the flip of a coin.

### SC-150. SHOW HIGH POINT PERFORMANCE AWARD

- A. **AWARD NOT MANDATORY.** It is not mandatory for a **Show High Point Performance Horse** award to be made at an approved show; however, if such an award is designated the following scoring system shall be used to determine the winner.
- B. **PERFORMANCE EVENTS AND POINTS.** To be eligible for High Point Performance Horse honors, a horse must compete in at least three approved performance events. Points will be awarded according to SC-145.A.2.-4.

### SC-155. RIBBONS

- A. **SEVEN PLACINGS.** Each class must be placed through the seventh horse, or whatever number is present, if fewer than seven (7) even though ribbons are not given to all seven (7) horses. If a horse is disqualified, it is not to be placed even if there were fewer than seven (7) qualified horses in the class. The following schedule of ribbons is recommended for all shows and contests.

#### **Ribbons to six places.**

1st place.....	blue
2nd place.....	red
3rd place.....	yellow
4th place.....	white
5th place.....	pink
6th place.....	green
Grand Champion Stallion, Mare or Gelding.....	purple
Reserve Champion Stallion, Mare or Gelding.....	purple & white

### SC-160. GENERAL SHOW RULES

- A. **ELIGIBILITY TO SHOW.** A show must be open to all Paint Horse owners in good standing with the APHA to gain approval. No exhibitor may be required to be a member of any organization in order to compete in an approved class.
- B. **DENYING OR RESTRICTING ENTRIES.** Any show that

denies or restricts entries in any one of the events listed in SC-175, SC-180 or SC-190 will not have their show results approved.

- C. **REGISTRATION PAPER INSPECTION.** Show management must inspect the registration certificate or photocopy of registration certificate of each horse entered in an approved class. Entries shall be made in the name of the recorded owner.
- D. **ENTRY WITHDRAWAL.** Any contestant withdrawing from a contest after entering shall forfeit his entry fee and all Go-Round or Day money which may be accruing to him at the time of his withdrawal; except, that in case of incapacitating sickness or injury to himself or his horse, or serious illness or death of the contestant's family, all prize monies won by him to that point in the contest shall be paid.
- E. **EXHIBITOR RESPONSIBILITY.** Exhibitors are responsible for:
1. Being knowledgeable of and following the current rules as set forth by APHA and Show Management.
  2. Completing entry form legibly and accurately with information exactly as is printed on horse's registration papers.
  3. Pre-entering and post-entering horses in correct halter and performance classes. A horse entered in the wrong class may be transferred to its correct class prior to that class being judged.
  4. Reporting to the gate promptly for the class and notifying gate personnel of tack changes needed.
  5. Being considerate of other exhibitors and show management.
- F. **EXHIBITORS WITH SPECIAL NEEDS.** An exhibitor who is physically challenged and needs special accommodations may request a variance from the Executive Committee to have their special needs accommodated to be allowed to exhibit and be judged in APHA-approved classes. The Executive Committee will issue a letter to the exhibitor granting or denying the request, stating the accommodations necessary and classes to be exhibited in. The letter must be applied for at least thirty (30) days prior to the first show and on a yearly basis. The letter will be valid through December 31 of the current calendar year.
1. It is the exhibitors' responsibility to present the letter or photocopy to the show management when making their entries.
  2. It is show management's responsibility to inform the judges of special accommodations being used.
- G. **ENTRY FEES.**
1. **All Day Fees.** An exhibitor may be required to go in a set number of classes; however, no specific class may be required in order to receive all day fees.
  2. **Forced Entry.** An **approved** Paint Horse show may not require that an exhibitor enter or pay entry fees in any class to be eligible for another class. For example, a show or contest may not require entries in halter to show in performance classes, or vice versa.
  3. **Paying Another Exhibitor's Entry Fee.** No person shall

pay another exhibitor's entry fee for the purpose of enlarging an approved class nor shall any person accept payment of an entry fee for another to enlarge a particular class. Violation of this rule shall disqualify both horses involved in the transaction and shall be referred to the proper APHA authority for further disciplinary action as warranted.

- H. **ENTRY NUMBERS.** Entry numbers must be assigned to horses, not exhibitors, and the exhibitor must display the correct number assigned for the horse being exhibited in APHA approved shows. If exhibitor elects to display number on saddle pad in performance events, it must be on both sides. Failure by exhibitor to display the correct number and in a visible manner while being judged shall result in disqualification from the class.
- I. **DISQUALIFIED HORSES.** Disqualified Horses Are Not To Be Placed.
1. If a horse is disqualified, it is not to be placed, regardless of the number of horses in the class, but counts as an entry in the class.
  2. A judge may disqualify an exhibitor and/or horse from competition for any condition the judge considers unsafe, but counts as an entry in the class.
  3. Disqualification of an exhibitor and/or horse by the APHA Performance Dept. due to a violation of an eligibility rule set forth by the current APHA rule book will not be placed and the number of entries will be lowered. *EXCEPTION: Geldings which are still listed as stallions according to APHA records at the time the show results are processed at the APHA office will be disqualified from halter (Youth, Amateur and Open), and all Youth classes, but entries will not be lowered.*
- J. **PREMIUM MONEY.** If premium money (pay back) is provided the show management must make the full premium payments. The management cannot require a portion of the premium money to be added to any open sweepstakes or championship class. It shall be the option of the exhibitor to pay his fees for a championship or other sweepstakes event.
- K. **SHOW SCHEDULE TIME.** An approved show will not be permitted to start earlier than the advertised schedule.
- L. **POSTING PATTERNS/COURSES OR SPECIAL INSTRUCTIONS.** All patterns, courses or special instructions shall be posted one hour before the class is held.
- M. **ANNOUNCING NAMES OF HORSES/OWNERS /EXHIBITORS.** Show management shall not announce the names of horses, owners and/or exhibitors prior to judging being completed in a class. All entries should be referred to by exhibitor number.
- N. **IMMEDIATE FAMILY.** For horse show purposes, the term "immediate family" shall include the following: husband, wife, parent, stepparent, child, stepchild, brother, sister, half-brother and half-sister. For Amateur and Youth eligibility and ownership see AM-010, AM-020, YP-010, YP-015.
- O. **GENERAL WEARING APPAREL.** In all western events, speed events and halter, it is mandatory to wear appropriate

Western attire including long sleeves with collar (band, tuxedo, stand-up, etc.), western hat, and cowboy boots. The use of spurs, chaps, and hardhats are optional.

- P. **LAMENESS.** Obvious lameness is cause for disqualification. Obvious lameness is:

1. Consistently observable at a trot under all circumstances.
2. Marked nodding, hitching or shortened stride.
3. Minimal weight-bearing in motion and/or at rest, an inability to move.

The judge shall communicate any lameness to their ring steward who may remove an entry from the arena at the judge's discretion. In a multi-judge show, the ring stewards may remove an entry from the arena if the majority of judges disqualify a horse due to lameness.

### **SC-165. REGISTRATION REQUIREMENTS FOR HALTER and/or PERFORMANCE**

- A. **REGISTRATION REQUIREMENTS.** Effective January 1, 1969, all approved APHA shows or contest entries will be limited to Paint Horses registered in the APHA regular or APHA Appendix Registry, the APQHA, or the APSHA. See Rule RG-010.B.
- B. **FULL REGISTERED NAME MUST BE USED.** Any horse registered with the APHA must be entered in any show or contest using the complete registered name and registration number or appendix code to be eligible for APHA points.
- C. **EFFECTIVE JANUARY 1, 1980, HORSES REGISTERED IN THE BREEDING STOCK, APPENDIX BREEDING STOCK AND IDENTIFICATION REGISTRIES ARE ELIGIBLE TO COMPETE IN BREEDING STOCK CLASSES ONLY. See Rule RA-000.D.**  
EXCEPTION: EFFECTIVE JANUARY 1, 1987 BREEDING STOCK SIRES OR DAMS MAY BE ENTERED IN THE FOLLOWING GROUP HALTER CLASSES: PRODUCE OF DAM AND GET OF SIRE, PROVIDED THE REQUIREMENTS OF RULE SC-180.A. ARE MET.
- D. **APPENDIX REGISTRATION.** A horse's Appendix registration certificate is valid for APHA shows and contests for the following: weanling, yearling, two-year-old and three-year-old years.

### **SC-170. AGE REQUIREMENTS**

- A. **AGE DETERMINATION.** For the purpose of determining eligibility for competition, the age of a horse shall be computed by the calendar year starting on January 1 of the year foaled, i.e., it is a weanling during the calendar year in which foaled, regardless of the time of year foaled; a yearling during the first calendar year following its foaling date. For example: a horse foaled any time in 2002, will be termed 1 year old January 1, 2003, 2-years-old, January 1, 2004, etc.
- B. **EXAMINATION OF TEETH FOR AGE.** A horse is not eligible to participate in events approved by the APHA if its age as determined by examination of its teeth does not correspond

to the age shown on its registration certificate, such determination by tooth examination to be made in accordance with the current Official guide for Determining the Age of the Horse as adopted by the American Association of Equine Practitioners.

1. **Requested Examination.** Every exhibitor-owner or trainer shall, upon request by a representative of the APHA, show manager, or stewards at a race meet, permit such examination to be made by a representative of the APHA and/or licensed veterinarian. Refusal to comply with such request shall constitute grounds for immediate disqualification of the animal from the APHA events in progress or any other APHA approved event, and shall constitute grounds for suspension of Association membership
2. **Erroneous Age By Examination.** Should such examination show the animal's age does not correspond to the foaling date on its registration certificate, such examination shall constitute prima facie evidence that the animal's age as shown on its registration certificate is erroneous. The animal automatically shall be suspended from participating in the APHA event in progress and any future APHA approved events pending a hearing before the Executive Committee.
  - a. **Registration Certificate Delivery.** The exhibitor, owner, or trainer shall, upon request by a representative of the APHA, show manager or stewards at a race meet, deliver the animal's registration certificate to the requesting party. The representative of the APHA, show manager or stewards at a race meet receiving the registration certificate immediately shall forward the certificate and affidavits from the person or persons making such examination and findings, to the Executive Secretary of the Association.
  - b. **Hearing To Be Held.** At a time and place designated by the Executive Committee, a hearing will be held, at which time the animal's recorded owner and/or breeder shall provide evidence to substantiate the foaling date shown on the registration certificate. In absence of substantial evidence to the contrary, the Executive Committee of the Association may cancel the animal's registration and take appropriate action against the person or persons involved.

## SC-175. HALTER CLASS GENERAL RULES

- A. **WITHDRAWING.** Any contestant withdrawing from a contest after entering shall forfeit his entry fee and all Go-Round or Day money which may be accruing to him at the time of his withdrawal; except that in case of incapacitating sickness or injury to himself or his horse, or serious illness or death in the contestant's family, all prize monies won by him to that point in the contest shall be paid.
- B. **PROMPT ENTRY INTO THE ARENA.** All horses entered in a class to be judged must be assembled at the entrance to the arena in ample time for the judging to start promptly and to continue without delay, and shall remain there, except while

competing, until dismissed by the judge, unless the judge shall otherwise direct. A tardy contestant may be denied competition.

- C. **UNREGISTERED WEANLINGS.** Only weanlings may be exhibited without a registration certificate. At APHA sponsored shows all horses exhibited must be registered in the APHA, APQHA or APSHA. No points, awards or titles will be added to the horse's record as an unnamed weanling.
- D. **SHOW IN ONLY ONE POINT EARNING CLASS.** A horse may show in only one point-earning halter class. This does not prohibit a horse from being shown in a Youth and/or Amateur halter class in addition to the open age-group halter class of the show. See rules AM-090 and YP-085.
- E. **CANNOT COMBINE NON-POINT AND POINT EARNING AGE HORSES.** Halter classes may be combined using point-earning-age horses of the same sex. No halter class can be combined using a non-point earning age horse with point earning age horses except in Breeding Stock halter classes.
- F. **SEX DIVISIONS.** No halter class can be combined which would include another sex division. Exception: group halter classes.
- G. **GELDINGS STILL LISTED AS STALLIONS WITH APHA.** Geldings which are still listed as stallions according to APHA records at the time the show results are processed at the APHA office will be disqualified, *but entries will not be lowered.*
- H. **JUDGING SEX DIVISIONS PRIOR TO GRAND AND RESERVE.** All halter classes of any sex division, including Amateur, must be judged prior to the Grand and Reserve of that sex division. Exception: Youth classes.
- I. **HALTER AND ARTIFICIAL TAILS.** Horses shall be exhibited in a halter. Artificial tails consisting of fabric and hair are permissible.
- J. **JUDGING IN THE ARENA.**
  - 1. The judge shall make an individual examination for conformation defects, soundness and way of travel of each horse at the walk and jog-trot as it is led directly to and away from the judge and additionally the jog from a direct side angle. The judge may ask for any further individual examination he feels is needed. Any deviation from correct leg conformation and way of going shall be penalized. The horse must move straight and true. This is essential regardless of whether the competition indicated that it is necessary or not. The walk should be a natural flat-footed four beat gait. The walk must be alert, with a stride of reasonable length for the size of the horse. The jog-trot should be smooth, ground covering two beat diagonal gait. The jog-trot should be square, balanced with straight forward movement of the feet.
  - 2. The ideal standard in evaluating horses in halter classes should include, but not limited to, *a positive combination of balance, breed and sex character*, soundness and correctness of conformation, particularly feet and legs, with emphasis on correct manner of travel *and muscling.* The

horse should be fourteen (14) hands or taller, or if a stallion *two-years-old and older*, should have two testicles descended; that the horse should not be gaited (rack or pace); that the biting surfaces of the upper and lower incisors should touch (*parrot mouth or monkey mouth*); and that horse should not exhibit any other physical unsoundness. If any of the above undesirable conformation traits are exhibited, the horse shall be *heavily penalized, so as to not be placed over a horse in a point-earning placing*. Obvious lameness is cause for disqualification. *Lame horses should be excused from the ring prior to final placing by the judge*. Obvious lameness is:

- a. Consistently observable at a trot under all circumstances.
- b. Marked nodding, hitching or shortened stride.
- c. Minimal weight-bearing in motion and/or at rest, and inability to move.

**K. HALTER CLASSES:** The following halter classes are recommended for every show:

**1. Mares**

- a. Weanling fillies, foaled in calendar year of show.
- b. Yearling fillies, foaled in calendar year preceding show.
- c. Two-year-old fillies.
- d. Three-year-old fillies.
- e. Four-year-old and older mares.
- f. Broodmares. Mares shown in the broodmare class are not eligible to compete in any other classes listed in SC-175.K.1.a.- e. at the same show or contest. Only mares which have conceived and carried a full term foal in the current or previous year are eligible. If the foal has not been registered out of the mare during this period, a Broodmare Eligibility form advising status of the full term foal must be signed by the owner of the mare upon entering the class or each exhibitor competing in a broodmare class must possess a broodmare status card. Show management must inspect this card at any show entered. Application for a broodmare status card can be made by sending a written statement with all pertinent information to APHA.

**g. Grand and Reserve Champion Mare.**

1. **Grand Champion Mare**, chosen from **first** place winners. Exception: If for any reason the first place horse fails to return for grand and reserve, the second place horse can be considered for the grand or reserve champion placing.
2. **Reserve Champion Mare**, chosen from **second** place winner in the **Grand** Champion mare's class and **first** place winners in other classes, all remaining second place horses may be excused. **EXCEPTION:** If for any reason the first place horse fails to return for grand and reserve, the second place horse can still be considered for the reserve grand champion placing.

2. **Stallions.**
  - a. Weanling colts, foaled in calendar year of show.
  - b. Yearling colts, foaled in calendar year preceding show.
  - c. Two-year-old stallions.
  - d. Three-year-old stallions.
  - e. Four-year-old and older stallions.
  - f. **Grand and Reserve Champion Stallion.**
    1. **Grand Champion Stallion**, chosen from **first** place winners. Exception: If for any reason the first place horse fails to return for grand and reserve, the second place horse can be considered for the grand or reserve champion placing.
    2. **Reserve Champion Stallion**, chosen from **second** place winner in the **Grand** Champion Stallion's class and **first** place winners in other classes, all remaining second place horses may be excused. See Exception in Rule SC-175.K.1.g.2.
3. **Geldings.**
  - a. Weanling geldings, foaled in calendar year of show.
  - b. Yearling geldings, foaled in calendar year preceding show.
  - c. Two-year-old geldings.
  - d. Three-year-old geldings.
  - e. Four-year-old and older geldings.
  - f. **Grand and Reserve Champion Gelding.**
    1. **Grand Champion Gelding**, chosen from **first** place winners. Exception: If for any reason the first place horse fails to return for grand and reserve, the second place horse can be considered for the grand or reserve champion placing.
    2. **Reserve Champion Gelding**, chosen from **second** place winner in **Grand** Champion Gelding's class and **first** place winners in other classes, all remaining second place horses may be excused. See Exception in Rule SC-175.K.1.g.2.
4. It is mandatory that all approved shows select Grand and Reserve Champions in each sex division. See Rules SC-065. and SC-175. *APHA will so note the awarding of the title of Grand Champion and Reserve Champion Stallion, Mare and Gelding on the performance record only when at least three horses are exhibited in that sex division.*

## SC-180. GROUP HALTER CLASSES

- A. **ADDITIONAL CLASSES.** The following are additional classes that are recommended if interest or entries justify them, but no points will be awarded. Horses shown in a group class must be eligible for or registered in the Regular or Appendix Registry to show in their individual halter class at that show.
  1. **Produce of Dam.** Two produce, either sex, can show. Dam must be registered with the APHA, but need not be shown nor need produce be owned by owner of the dam. Horses actually shown as the Produce of Dam will be limited to horses four years old and younger. EXCEPTION: See Rule SC-165.C.

2. **Get of Sire.** Three get, either sex, can be shown. Sire must be registered with the APHA, but need not be shown nor need get be owned by owner of sire. Horses actually shown as the Get of Sire will be limited to horses four years old and younger.  
EXCEPTION: Rule SC-165.C.
3. **Mare and Foal.** Mare with one of her foals to be shown. Foal must have been foaled within the current calendar year. Mare and foal do not have to be owned by the same owner. Mare must have a number in Regular Registry.
4. **Sire and Get.** Sire with two get to be shown. Sire and get do not have to be owned by the same owner. Horses shown as the get in this class will be limited to horses four years old and younger. Sire must have number in Regular Registry.
5. **Exhibitor's Group.** Group of four head, any age or sex, all owned by the exhibitor and recorded in the Association office to that one ownership.

### SC-185. PERFORMANCE GENERAL RULES

- A. **WITHDRAWING AFTER ENTERING.** Any contestant withdrawing from a contest after entering shall forfeit his entry fee and all Go-Round or Day money which may be accruing to him at the time of his withdrawal; except, that in case of incapacitating sickness or injury to himself or his horse, or serious illness or death in the contestant's family, all prize monies won by him to that point in the contest shall be paid.
- B. **BANDAGES.** In any performance class, an open leg wound may be covered by a bandage not to exceed 1 1/2 wraps of vet wrap or similar material and not over 4 inches in width.
- C. **PROMPT ENTRY INTO THE ARENA.** All horses entered in a class to be judged must be assembled at the entrance to the arena in ample time for the judging to start promptly and to continue without delay, and shall remain there, except while competing, until dismissed by the judge, unless the judge shall otherwise direct. A tardy contestant may be denied competition.
- D. **COMPETING IN MORE THAN ONE APHA SPECIFIC CLASS EVENT.** No horse shall be allowed to compete in more than one APHA-approved class in any one specific type of event at a show, i.e., a horse may not be exhibited in two registered calf roping events or two registered reining events. However, a horse can be exhibited in a registered event and the same event in Youth or Amateur competition.
- E. **AGE DIVISIONS.** Performance classes may be divided into a maximum of two sections, based on the age of the horse. Any exception will be specified in the appropriate event.
  1. Junior horses, five years and under.
  2. Senior horses, six years and over.
  3. All ages, junior and senior horses combined.
  4. Eligible Age For Performance Class Entry. No horse shall be exhibited in a performance class prior to January 1 of its two year old year. Exception: Showmanship and Yearling Longe Line.

5. Junior horses being shown in a hackamore or snaffle bit must be ridden with two hands. See rule SC-240.D.E.

**F. RIDING MULTIPLE HORSES.** An exhibitor may exhibit a maximum of *four horses, up to two Junior and up to two Senior horses*, in individual working events, barrel racing, calf roping, cutting, jumping, heading, heeling, pole bending, reining, steer stopping, trail, western riding, working hunter, working cowhorse, and utility driving. Each horse may have only one rider or driver per class. See rule SC-185.E.

**G. SPLITTING AND COMBINING CLASSES.** Show management may combine or split age groups as justified by entries if there is unanimous consent of all involved exhibitors, however, if one division is not a point earning class, then show management may combine age groups, without unanimous consent of all exhibitors, in order to make the division a point earning class.

**H. POSTING OF PATTERNS/COURSES OR SPECIAL INSTRUCTIONS.** All patterns, courses or special instructions for classes requiring such shall be posted *at least one hour before the scheduled time of class*.

**I. ORDER OF COMPETITION FOR INDIVIDUAL PATTERNS.** A working order may be established by drawing for that order. The exhibitor does not necessarily need to be present during the drawing. This working order may be altered at the show management's discretion if necessary.

**J. GO ROUNDS OR ELIMINATIONS.** The management of any contest shall determine whether or not an elimination is necessary, the number of go-rounds to be held, and the number of horses to be shown at each performance.

1. **Elimination.** If there is an elimination, the same rider must ride the same horse in the elimination and the class.

2. **Score.** The score of each horse in the finals plus his score in an elimination or go-round, or both will determine the final placing; consistency of performance to be recognized as a major factor.

**K. RERUNS.** Reruns shall not be allowed in any performance classes in the event of an exhibitor having equipment failure. Reruns shall be given in speed events because of timer failure or in roping events if the barrier malfunctions.

**L. FAULTS OR PENALTIES.** In all performance classes, horses are to be judged on performance ability only. The word "faults" or "penalties" in this rule book shall not be misinterpreted as meaning a cause for disqualification.

1. **Artificial Tails and Braids.** Artificial tail braids are not to be penalized. Artificial tails consisting of fabric and hair are permissible.

2. **Tail Carriage.** No horse is to be penalized for the manner in which he carries his tail nor for normal response with his tail to cues from his rider when changing leads. A judge may, at his discretion, penalize a horse for excessive or exaggerated switching or wringing of the tail or for a seemingly "dead" tail that merely dangles between the legs and does not show normal response.

**M. DISQUALIFICATION.**

1. **Rider Falling Off Horse.** Rider falling off horse during competition will be cause for disqualification.  
EXCEPTIONS: See Rule SC-265.L. and SC-275.D.7.
  2. **Exhibitor Hitting Horse.** For hitting or spurring a horse forward of the cinch in any approved event. Exception: Unless the individual event rule specifies otherwise.
  3. If equipment failure disrupts class routine, horse will be disqualified.
  4. **Lameness.** Obvious lameness is cause for disqualification. Obvious lameness is:
    - a. Consistently observable at a trot under all circumstances.
    - b. Marked nodding, hitching or shortened stride.
    - c. Minimal weight-bearing in motion and/or at rest, an inability to move.

The judge shall communicate any lameness to their ring steward who *must* remove an entry from the arena at the judge's discretion. In a multi-judge show, the ring stewards *must* remove an entry from the arena if the majority of judges disqualify a horse due to lameness.
- N. **TIES.** No contest is complete until all ties to seventh place have been worked off or settled by flip of a coin.

## SC-190. PERFORMANCE CONTESTS

- A. **PERFORMANCE EVENTS.** Only APHA registered horses two years old and older may be exhibited in performance classes. The performance contests shown below may recognize the entry of any APHA registered horse as set in Rules RG-010.B. and SC-165.A. Exception: Yearling Longe Line.
1. Registered Hunter Under Saddle (BPH).
  2. Registered Hunter Hack.
  3. Registered Working Hunter.
  4. Registered Green Working Hunter.
  5. Registered Jumping.
  6. Registered Pleasure Driving.
  7. Registered Western Pleasure.
  8. Registered Western Riding.
  9. Registered Reining.
  10. Registered Trail Horse.
  11. Registered Working Cowhorse.
  12. Registered Cutting.
  13. Registered Calf Roping.
  14. Registered Team Penning.
  15. Registered Team Roping Heading.
  16. Registered Team Roping Heeling.
  17. Registered Steer Stopping.
  18. Registered Barrel Racing.
  19. Registered Pole Bending.
  20. Registered Cow Pony Race.
  21. Registered Utility Driving
  22. Registered Stake Race
  23. Registered Yearling Longe Line

## SC-191. YEARLING LONGE LINE

- A. Class is limited to yearlings. Points in this class will be applied toward an ROM. Points in this class will not count toward an APHA Championship or any other APHA awards.
- B. *The purpose of showing a yearling on a longe line is to demonstrate that the horse has the movement, manners/expression/attitude, and conformation to become competitive under saddle. Therefore, the purpose of this class is to reward:*
1. *Quality of movement*
  2. *Manners/Expression/Attitude*
  3. *Conformation suitable to future performance, and the horse should be judged with its suitability as a future performer under saddle in mind. This class should define what it means to be a "western pleasure prospect" or "hunter under saddle prospect." Because these are yearlings, they are not expected to demonstrate the behavior or quality of a finished show horse, but only that performance necessary for a reasonable presentation to the judge.*
- C. *Equipment. Horses are to be shown in a halter. Either a regular or a show type halter is acceptable. For the longing demonstration, the only attachment allowed to the halter is a longe line. The longe line may not exceed 30 feet with a snap attached to the halter. The longe line must hang free from the halter without touching any part of the horse. It is permissible to use a longe whip however, disqualification will occur if the exhibitor blatantly strikes the horse with the whip to cause forward or lateral movement at any time during the longing demonstration. No other equipment is allowed on the horse during longing demonstration portion of the class. Mechanical or retractable longe lines are not allowed. For the conformation inspection, a lead shank, such as used in halter or showmanship classes may be exchanged for the longe line prior to the longing demonstration. Exhibitors are not to be penalized for using regular halters and plain longe lines, nor are they to be rewarded for using show halters and show longe lines. Only movement, manners/expression/way of going, and conformation are being judged. The type of equipment used is not to be a consideration in placing the horse as long as the equipment meets the requirements stated above.*
- D. *Attire. Conventional Western attire is mandatory according to SC-235 except if a prospect is considered to be a Hunter prospect, the mane may be braided and conventional English attire is suggested according to SC-195. The type of attire worn by the exhibitor is not to be a consideration in placing the horse as long as the attire meets the requirements stated above.*
- E. *Gaits to be judged according to APHA rules for gaits for western pleasure (SC-245.E.) and hunter under saddle (SC-205.F).*
- F. *The conformation inspection will occur as the horse is walked into the arena prior to the longing demonstration at which time the judge will also evaluate the horse for conformation suitable for future under saddle performance. The judges may not discriminate for or against muscling, but rather look for a total pic-*

*ture, emphasizing balance, structural correctness, and athletic capability. Each entry will be walked into the arena to the judge and pause for evaluation individually. They will then trot off straight and around a cone and take a place on the wall inside the arena. All entries will be inspected in this fashion and as the "trot-off" is administered, horses showing evidence of lameness should be excused from the class at that time.*

- G. *Judge(s) will be outside the longing circle. The exhibitor will enter the longing area and await the audible start signal. When the signal is given, the exhibitor will be allowed 1 1/2 minutes (90 seconds) to present the horse. At the end of 1 1/2 minutes, a signal will be given again to signify the end of the demonstration. Show management has the option of adding a "half-way" signal if they choose. (The signal may be a bell, whistle or announcement.)*
- H. *The horse will be scored at the walk, jog or long trot, and lope or canter in both directions. Any horse that does not exhibit these gaits in each direction will be disqualified from the class. Additionally, the judge shall immediately excuse any horse who exhibits obvious lameness at any time during the class. Exhibitors may begin work in the direction of their choice (counter or clockwise).*
- I. *At the end of the 1 and 1/2 minutes, a signal will be given and the exhibitor shall at the request of show management, retire from the longing area and retire to the far end of the ring. The horses are to stand quietly on the rail while the other exhibitors are being judged.*
- J. *The horses are judged on movement (80%) according to APHA rules for gaits (SC-205.F. and SC-245.E.). Manners/Expression/Attitude (10 points) and conformation suitable to purpose (20 points). Judges may not discriminate for or against bulk, but rather look for a total picture, emphasizing balance and athletic capability.*
- K. *If the horse plays on the longe line, it shall not count against the horse. The judge will, however, penalize the horse for excessive bucking or running off, stumbling or displaying attitudes that are uncomplimentary to pleasure horses. Falling down will constitute disqualification. Credit is to be given to the horse that, under light control and without intimidation, goes softly and quietly while performing the required gaits. The overall picture of a good mover is a horse that goes forward with comfort, confidence and willingness, a fluid stride with a full extension of the limbs, and a head and neck carriage that is naturally comfortable and compatible with the horses' conformation. Transitions will be smooth, without interruption of forward motion. The horse will exhibit a pleasant look, with clear, bright eyes and a willing attitude. Credit will be given to fluid movement and correct cadence.*
- L. *Exhibitors are encouraged to exhibit their horse making full use of a longing circle having a 25' radius (7.5m).*
- M. *An exhibitor may only show one horse in each longe line class. The same exhibitor must show in both segments of the class.*
- N. *Scoring: NSBA scoring is recommended.*
  - 1. *Movement will count for 80 points of the total score.*

- a.. *Walk.* The walk will be scored on a scale of 0–4 in each direction, with 2 being average. The horse must be walked long enough for the judge to have sufficient time to evaluate and score the walk. The change of direction turnaround at the walk may count for the second walk score on the official score sheet. Lower gait scores should reflect stumbling in the gait.
  - b. *Jog or Trot.* The jog/trot will be scored on a scale of 0–16 in each direction, with 8 being average. Using a 25' radius (7.5m), the horse should jog or trot a minimum of 1/2 circle both directions of the ring. Lower gait scores should reflect stumbling in the gait.
  - c. *Lope or Canter.* The lope/canter will be scored on a scale of 0–20 in each direction, with 10 being average. Using a 25' radius, the horse should lope or canter a minimum of one full circle both directions of the ring. Furthermore, any entry that fails to demonstrate the correct lead for one full circle will not place over another entry that has demonstrated the correct lead in its entirety. Lower gait scores should reflect stumbling in the gait.
  - d. *Use of Circle.* Scores for all gaits in both directions should reflect positive, consistent use of the 25' radius (7.5m) of the circle. Extra credit will be given for full, extended use of the circle on a slightly loose line. Lower gait scores should reflect lack of full use of the circle.
2. *Manners/Expression/Attitude* will count for up to 10 points of the total score. The horse will be judged on manners, expression, and attitude on a scale of 0–10, with 5 being average. Horses will be penalized for obvious signs of overwork and sourness such as ear-pinning, head-throwing, striking, tail-wringing, or a dull, lethargic manner of going. They will also be penalized for dangerous behavior such as excessive bucking, cutting into the circle, or running off. Additionally, incidental touching the horse with the whip, cross-cantering, balking, backing up on the longe line and excessive urging from the exhibitor should be penalized accordingly.
  3. *Conformation* will count for up to 20 points of the total score. The horse will be judged on conformation suitable to future performance as a Western Pleasure or Hunter Under Saddle competitor. The judges should look for a total picture, emphasizing balance, structural correctness, and athletic capability. Performance conformation will be judged on a scale of 0–20, with 10 being average.
  4. *Use of the circle.* Consideration will be given to how well or how poorly the horse/exhibitor team uses the 25' radius (7.5m) of the longing circle. A separate box on the score-card is available to indicate an overall score (from 0-3 points) for use of the circle.

*Circle Scores:* As described earlier, a 25' radius (7.5m) is the appropriate size of circle in which to show a longe liner. It is the judge's responsibility to evaluate the cir-

*cles and incorporate use of the circle in the gait scores based on the following scale:*

*+3 points (Good to Excellent Use of the Circle). Horse consistently stays on the perimeter of the circle with slight looseness in the line. Horse turns around on the circle perimeter.*

*+2 points (Average use of the circle). Horse is only slightly inconsistent in using the 25' radius (7.5m) of the circle.*

*+1 point (Adequate use of the circle) Horse is shown in a circle radius of less than 25' (7.5m).*

*0 points (General use of the circle) Potentially dangerous slack in the line. Horse pulls exhibitor out of the circle.*

5. *Other scoring considerations: This class should be looked upon as a class that defines what it means to be a "pleasure prospect" or "hunter prospect" suitable to become a future performer under saddle. Therefore, attitudes and attributes that contribute to becoming a future performer will be rewarded within the gait scores. Higher gait scores will reflect: Above average to exceptional manners, expression, alertness, responsiveness, and pleasant attitude, above average to exceptionally smooth transitions between gaits, above average to excellent cadence and consistency at all three gaits.*

6. *Penalties and disqualifications.*

a. *Five (5)-point penalties: Failure to demonstrate the correct lead, jog or trot for an adequate distance to allow for proper evaluation of gait.*

b. *Disqualification will occur in the following instances: Evidence of lameness—judge will immediately excuse horse from the arena, blatant striking horse with the whip during the longing demonstration that will cause forward or lateral movement, horse falls—A horse is considered to have fallen when it is on its side and all four legs are extended in the same direction, horse steps over or becomes entangled in the longe line, failure to show at all three gaits in both directions, loss of control of the horse to the point that the horse is loose in the arena, exhibitor disrespect towards the judge(s).*

## **SC-195. ENGLISH ATTIRE AND PERSONAL APPOINTMENTS**

### **A. ENGLISH ATTIRE AND PERSONAL APPOINTMENTS.**

Exhibitors and judges should bear in mind that, at all times, entries are being judged on ability rather than on personal attire. However, riders should wear coats of any tweed or melton for hunting, conservative wash jackets in season, *traditional shades of conservative English colored breeches or Hunt jodhpurs*, high English boots or jodhpur boots. Dark blue, black or brown hunting cap or black or brown hunt derby is mandatory. Stock, tie or choker is required. Hair must be neat and contained, as in a net or braid. Judges must penalize contestants who do not conform. Exception: Helmet with harness

properly attached under the chin is required for all youth participating in any warm up/schooling area or class involving jumps, (english division classes only). See equipment and attire chart in back of rule book.

- B. Judges at their discretion, may authorize adjustments to attire due to weather-related conditions.

## SC-200. ENGLISH TACK

### A. ENGLISH TACK.

1. **Saddles.** Heavy, plain leather skirted saddles (of hunt seat type) or forward (hunt seat) type may have suede seat and/or suede inset on skirt and either leather or cloth lining. Either leather, web, cord or linen girths are permitted.
2. Saddle pads should fit size and shape of saddle, except when necessary to accommodate numbers on both sides, for which a square pad or suitable attachment may be used. Saddle pads and attachments shall be white or natural color with no ornamentation.
3. **Bridles.** In all English classes, an English snaffle (no shanks), kimberwick, pelham and/or double bridle consisting of two bits—a curb or weymouth and a snaffle or bradoon—with two reins, no converters allowed, all with cavesson nosebands and browbands are acceptable.
4. **Bits.** A port must be no higher than 1 1/2 inches (3.81cm).
  - a. **On broken mouthpieces.** The mouthpiece may be two or three pieces, if it is three pieces, a connecting ring must be no larger than 1 1/4 inches (3.17cm) outside diameter, or a connecting flat bar must be no longer than 2 inches (5.08cm) and 3/8 inch (0.95cm) to 3/4 inch (1.9cm), measured top to bottom, and must lie flat in horse's mouth. **See Rule SC-205.B.3.b.**
  - b. All smooth, round, twisted, slow twist, corkscrew, double twisted wire (mouthpieces) and straight bars or solid mouthpieces with a maximum port height of 1 1/2 inches (3.81cm) are acceptable.
  - c. Nothing, such as extensions or prongs may protrude below the mouthpiece (bar). All mouth pieces must be a minimum of 5/16 inch (.79cm) in diameter measured one inch (2.5cm) from the cheek.
  - d. **Illegal.** English bits of any style featuring cathedral, fishback, or donut mouthpiece; rough, sharp material, or mechanically altered bits are illegal and shall be cause for disqualification.
  - e. *Any bit having a fixed rein requires use of a curb chain, which must be at least 1/2 inch (1.27 cm) in width and lie flat against the jaw of the horse.*
  - f. The judge may prohibit the use of bits and equipment he may consider too severe.
  - g. A bit cannot be physically or mechanically changed to increase the severity of its use and may be eliminated at the discretion of the judge.
  - h. **Bloody Mouth.** In all divisions, if a horse's mouth is found to be bloody, disqualification is at the discretion of the judge.

**i. Acceptable English Bits. Unacceptable Bits.**

**English Bits**

**Examples of Acceptable Bits; exception 2-year-olds.**



Slow Twist



Corkscrew

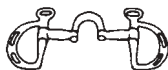

Correction Bit



Double Twisted  
Wire



Single Twisted  
Wire



Dr. Bristol

**Examples of Unacceptable Bits**



Excessive Port

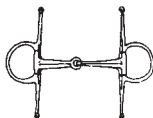

Triangular Mouth

**5. Optional Appointments.**

- a. Spurs of the unrowelled type.
- b. Crops or bats.
- c. Hunting breast plate.
- d. Braiding of mane and tail in hunt type.
- e. Roached mane allowed.
- f. Artificial tailbraid allowed. See Rule SC-185.L.1.

**6. Prohibited Appointments.**

- a. Running or standing martingales. Exception: See Rule SC-215.A. and SC-220.A.
  - b. Rowelled spurs.
  - c. Dropped nosebands. Dropped nosebands shall be interpreted as a cavesson or nose band which is fastened below the bit or mouthpiece.
  - d. Draw reins.
  - e. Legwraps or Boots of any description on the horse.
- 7. See equipment and attire chart in back of rule book.**

**SC-205. HUNTER UNDER SADDLE**

- A. **ENGLISH ATTIRE AND TACK.** See Rule SC.195. & SC-200.
- B. **THREE APPROVED CLASSES.** A show may have up to three approved Hunter Under Saddle classes. If three Hunter Under Saddle classes are to be offered at a show, they shall be the following:

1. **Senior** Hunter Under Saddle, six-year-old and older.
2. **Junior** Hunter Under Saddle, five-year-old and younger.
3. **Two-Year-Old** Hunter Under Saddle
  - a. Horses shown in this class will not be eligible for any other open Hunter Under Saddle class.
  - b. Horses must be shown in a regulation hunt snaffle bit with mouthpiece as follows: Bars of mouthpiece must be round, smooth and unwrapped metal no less than 5/16 inch (.79cm) in diameter measured one inch in from cheek with a gradual decrease to the center of the snaffle. May be inlaid, but smooth, or rubber latex wrapped. The mouthpiece must be two pieces.  
**Exception:** Three-piece mouthpiece may not be used.
- C. **TWO APPROVED CLASSES.** If two Hunter Under Saddle classes are to be offered at a show they shall be the following:
  1. **Senior** Hunter Under Saddle, six-year-old and older.
  2. **Junior** Hunter Under Saddle, five-year-old and younger.
- D. **ONE APPROVED CLASS.** If only one Hunter Under Saddle class is to be offered at a show, it shall be the following:
  1. **All Ages** Hunter Under Saddle.
- E. **MOVEMENT TO PURPOSE.** Hunter under Saddle should be suitable to purpose. They should move in a long, low frame and be able to lengthen their stride and cover ground, as in traversing hunt country following hounds. They should be obedient, alert and responsive to their riders. Quick short strides should be penalized. Horses which move in an artificial frame and are over flexed and behind the bit should also be penalized. Horses should be serviceably sound. Judges should emphasize free movement and manners.
  1. Horses to be shown under saddle, not to jump.
  2. Horses to be shown at a walk, trot and canter both ways of the ring. Horses should back easily and stand quietly.
  3. Horses may change gaits at the flat-footed walk or the trot at the judge's discretion. Light contact with the horse's mouth is recommended.
  4. The judge may, at his discretion, back only the finalists.
- F. **GAITS.**
  1. **Walk.** The walk should be a forward working walk, rhythmic and flat footed; extremely slow, or "jiggy" walk to be penalized.
  2. **Trot.** Trot long, low ground-covering, cadenced and balanced strides. Smoothness more essential than speed. Extreme speed to be penalized. Excessive knee action to be penalized.
  3. **Canter.** Canter smooth, free-moving, relaxed and straight on both leads. The stride should be suitable to cover ground following hounds. Over-collected, four-beat canter to be penalized. Excessive speed to be penalized.
  4. **Hand Gallop.** Hand gallop should be a definite lengthening of the stride with a noticeable difference in speed. The horse should be under control at all times and be able to pull up, not a sliding stop, and stand quietly. At the option of the judge, all or just the top eight horses may be required to hand gallop, one or both ways of the ring. Never more

than eight horses to hand gallop at one time. At the hand gallop, the judge may ask the group to halt and stand quietly on a free or loosened rein.

### **SC-210. HUNTER HACK**

- A. **ENGLISH ATTIRE AND TACK.** See rules SC-195. & SC-200.
- B. **RING PROCEDURE.** Horses will be shown at a walk, trot and canter both ways of the ring and shall be required to jump a minimum of two (2) jumps of two feet (2') (60.96cm) but not more than two feet, six inches (2'6") (76.12cm) in height. Jumps to be spaced on multiple of twelve (12) feet (3.65m), minimum of thirty-six (36) feet (10.97m). Obstacles to simulate those found in hunt field. See SC-215.D.2. A ground line on approach side of each fence is mandatory.
- C. **JUDGING JUMP PERFORMANCE AND RAIL WORK.** The class will be judged on an even hunting pace, manners, way of going and jumping style. Jumping phase will be scored as in the Working Hunter Class. Horses eliminated in over fence portion of the class shall be disqualified. The class shall be judged 70% on performance over fences, 30% on rail work.

### **SC-215. WORKING HUNTER**

- A. **ENGLISH ATTIRE AND TACK.** See rules SC-195. & SC-200. Exception: Running or standing martingales are permitted.
- B. **JUNIOR AND SENIOR WORKING HUNTER.** The same rules apply in junior working hunter as apply to senior or all-ages working hunter classes.
- C. **HUNT COURSE.** A hunter course shall be any course which management deems a fair test of a hunter. Judges are responsible for correctness of each course after it has been set and shall call the show committee's attention to any errors that would tend to result in unfair or inappropriate courses.
- D. **COURSE AND ARENA MANAGEMENT.**
  - 1. **Minimum Obstacles & Fences.** Minimum of four (4) obstacles. Horses to jump a minimum of eight (8) fences. One change of direction is mandatory.
  - 2. **Obstacles Which May Be Used.**
    - a. Fences shall simulate obstacles found in the hunting field, such as natural looking post and rail, brush, walls, coops and ascending oxers (not square). Triple bar and hogsback are prohibited. Striped poles are not recommended.
    - b. The top element of all fences must be securely placed so that a slight rub will not cause a knockdown.
    - c. Distance between fences is recommended to be in 12 foot (3.65m) increments with the exception of some combinations; one stride in and out, 24-26 feet (7.31-7.92m); two strides in and out, 36 feet (10.97m); three strides, 48 feet (14.63m).
    - d. Height of obstacle must be a minimum of 2 feet, six inches (2'6") (76.12cm) and a maximum of three feet

(3') (91cm).

- e. A variation of three inches (3") (7.62cm) in fence height, lower than official heights listed, may be instituted if show management and the judge feel circumstances warrant, i.e., footing, weather, etc.
- f. The use of wings on obstacles in hunter classes is recommended.
- g. Jump standards with heights at 3-inch (7.62cm) intervals with jump cups are recommended.

#### E. **SCORING.**

1. **To Be Judged.** On manners, way of going and style of jumping. Horses shall be credited with maintaining an even hunting pace that covers the course with free-flowing strides. Preference will be given to horses with correct jumping style that meet fence squarely, jumping at the center of fence. Judges shall penalize unsafe jumping and bad form over fence, whether touched or untouched, including twisting. Incorrect leads around the ends of the course or cross-cantering shall be penalized, as well as excessive use of crop. In and outs (one or two strides) shall be taken in the correct number of strides or be penalized. Any error which endangers the horse and/or rider, particularly refusals or knock downs, shall be heavily penalized.
2. **Scoring** shall be on a basis of 0-100, with an approximate breakdown as follows:
  - a. **90-100:** An excellent performer and good mover that jumps the entire course with cadence, balance and style.
  - b. **80-89:** A good performer that jumps all fences reasonably well, an excellent performer that commits one or two minor faults.
  - c. **70-79:** The average, fair mover that makes no serious faults, but lacks the style cadence and good balance of the scopier horses; the good performer that makes a few minor faults.
  - d. **60-69:** Poor movers that make minor mistakes; fair or average movers that have one or two poor fences but no major faults or disobediences.
  - e. **50-59:** A horse that commits one major fault, such as a hind knockdown, refusal, trot, cross-canter or drops a leg.
  - f. **30-49:** A horse that commits two or more major faults, including front knock downs and refusals, or jumps in a manner that otherwise endangers the horse and/or rider.
  - g. **10-29:** A horse that avoids elimination but jumps in such an unsafe and dangerous manner as to preclude a higher score.

#### F. **ELIMINATION.**

1. A total of three disobediences which can include any of the following: refusal, stop, run-out, or extra circle.
2. Jumping an obstacle before it is reset.
3. Bolting from the arena.
4. Off course.

5. Deliberately addressing an obstacle.
6. Horse and/or rider falling. Horse is considered to have fallen when shoulder and haunch on the same side touch the ground, or the obstacle and the ground.
7. Failure to trot the horse in a small circle on a loose rein for soundness, after jumping the fence, while still mounted and prior to leaving the arena.

#### G. **GENERAL.**

1. Circling once upon entering the ring and once before leaving is permissible.
2. Horse shall not be requested to rejump the course.
3. Manners shall be emphasized in youth and amateur class.
4. When an obstacle is composed of several elements, any disturbance of these elements will be penalized; however, only a reduction in height of the top element shall be considered a knockdown.
5. In cases of broken equipment, the rider may either continue without penalty, or stop and correct the difficulty and be penalized the same as any loss of forward impulsion.
6. When an obstacle requires two or more fences (in and out), faults committed at each obstacle are considered separately. In case of a refusal or run-out at one element, entry may rejump the previous elements.
7. **Disobediences (major faults).**
  - a. **Refusal.** When a horse stops in front of an obstacle (whether or not the obstacle is knocked down or altered), it is a refusal unless the horse then immediately jumps the obstacle without backing one step. If horse takes one step backwards it is a refusal.
    1. After refusal, if horse is moved toward the obstacle but does not attempt to jump, it is considered another refusal.
  - b. **Run-out.** A run-out occurs when the horse evades or passes the obstacle to be jumped; jumps an obstacle outside its limiting markers; or when the horse or rider knocks down a flag, standard, wing or other element limiting the obstacle (without obstacle being jumped).
  - c. **Loss of Forward Movement.** Failure to maintain trot, canter or gallop after crossing starting line, except when it is a refusal, a run-out or when due to uncontrollable circumstances, such as when an obstacle is being reset.
  - d. **Unnecessary Circling on Course.** Any form of circle or circles, whereby the horse crosses its original track between two consecutive obstacles anywhere on course, except to retake obstacle after refusal or run-out.
  - e. First disobedience anywhere on course - 3 faults.
  - f. Second cumulative disobedience anywhere on course - 6 faults.
8. Whenever possible, a schooling area should be provided with at least one practice jump.
9. Schooling over obstacles in the ring or over any part of an outside course is permitted only at the time designated by

show management.

### SC-216. GREEN WORKING HUNTER

- A. Eligibility. One class to include both:
  - 1. Horses in their first year of showing in approved APHA shows in green working hunter.
  - 2. All other horses that have shown during the previous year(s) in APHA-approved working hunter, green working hunter, or jumping, but have not won more than a total of ten (10) points in open, amateur, novice or youth working hunter, green working hunter or jumping events as of January 1 of the current show year.
    - a. Once a horse has earned ten (10) points in Green Working Hunter, it will no longer be eligible to compete in this class in subsequent years.
- B. Year Long Eligibility. If a horse is considered eligible on January 1, it may continue to be shown for the calendar year, in this class, regardless of points earned.
- C. Fence Heights. Two feet, six inches (2'6") (76.12cm) -three feet (3') (91cm).
- D. The same rules shall apply in green working hunter as apply in junior, senior and all-ages working hunter.
- E. Horses showing in this event may not show in any other open working hunter at the same show.
- F. Points earned in this class will count for all APHA awards. Exception: APHA Championship, Superior All-Around and Supreme Champion.

### SC-220. JUMPING

- A. **ENGLISH ATTIRE AND TACK.** See rules SC-195. and SC-200. **Exception.** Running or standing martingales, leg wraps, and/or boots permitted. In addition, choice of bits will include corkscrew, double twisted, and dull "edged" mouthpieces.
  - 1. The judge may prohibit the use of bits and equipment he may consider too severe. A bit cannot be physically or mechanically changed to increase the severity of its use and may be eliminated at the discretion of the judge.
- B. **ARENA ARRANGEMENT.**
  - 1. **Minimum Obstacles and Fences.** There will be a minimum of four obstacles; horses are to make a minimum of eight jumps.
  - 2. A spread fence consisting of two or more elements will be mandatory.
  - 3. It is recommended the first obstacle be no more than minimum height.
  - 4. **Optional Obstacles May Include.**
    - a. Post and rail (at least two)
    - b. Coop
    - c. Stone wall
    - d. Triple Bar
    - e. Brush jump
  - 5. Both a starting line at least 12 feet (3.65m) in front of the

- first obstacle, and a finish line at least 24 feet (7.31m) beyond the last obstacle must be indicated by markers (at least 12 feet, 3.65m, apart) at each end of the lines. Horse must start and finish by passing between markers.
6. Obstacles, except within combination, should be located a minimum distance of 48 feet (14.63m) apart, size of arena permitting.
  7. Height of obstacles must be a minimum of three feet (3') (91cm).
- C. **JUMP-OFFS.** Jump-offs will be held over the original course altered as outlined. In a jump-off, the sequence of obstacles may be in any order as long as the original direction is maintained. Only in the case of clean round ties, for first place or when points are involved, the height and spread of at least 50 percent of the obstacles shall be increased not less than three (7.62cm) and not more than six inches (15.24cm) in height, and to a maximum spread of six feet (1.82m). In case of ties involving faults, rails shall not be raised, courses may be shortened after the first round. However, the course may not be shortened to less than 50 percent of the original obstacles and must include at least one vertical and one spread jump. When a jump-off is required, the winner will be decided on the time only if faults are equal. If two or more horses are disqualified in the timed jump-off and are tied for a point, they are not to be rejumped, but flip a coin to break the tie.
- D. **TIME SHALL BEGIN.** Time shall begin from the instant the horse's chest reaches the starting line until it reaches the finish line. Time shall be stopped while a knockdown jump is being replaced, this is from the moment the rider gets his mount in a position to retake the jump until the proper authority signals that the jump has been replaced. It shall be the rider's responsibility to be ready to continue the course when the signal is given.
- E. **SCORING.** Jumpers are scored on a mathematical basis and penalty faults, which include knockdowns, disobediences and falls.
1. **Knockdowns.** An obstacle is considered knocked down and four faults assessed, when a horse or rider, by contact:
    - a. Lowers any part thereof which established the height of the obstacle or the height of any element of a spread obstacle even when the falling part is arrested in its fall by any portion of the obstacle; or
    - b. Moves any part thereof which establishes the height of the obstacle so it rests on a different support from the one on which it was originally placed.
    - c. Knocks down an obstacle, standard wing, automatic timing equipment or other designated markers on start and finish lines.
    - d. If an obstacle falls after the horse leaves the ring, it shall not be considered a knockdown.
  2. **Disobediences.**
    - a. **Refusal.** When a horse stops in front of an obstacle (whether or not the obstacle is knocked down or altered) it is a refusal unless the horse then immediate-

ly jumps the obstacle without backing one step. If horse takes one step backwards, it is a refusal.

1. After refusal, if horse is moved toward the obstacle but does not attempt to jump, it is considered another refusal.
  2. In the case of a refusal on an in-and-out jump, the horse must return to the start of the in-and-out sequence and rejump previous elements as well as following elements.
- b. **Run-out.** A run-out occurs when the horse evades or passes the obstacle to be jumped; jumps an obstacle outside its limiting markers; or, when the horse or rider knocks down a flag, stand, wing or other element limiting the obstacle (without obstacle being jumped).
  - c. **Loss of Forward Movement.** Failure to maintain trot, canter or gallop after crossing starting line, except when it is a refusal, a run-out or when due to uncontrollable circumstances, such as when an obstacle is being reset.
  - d. **Unnecessary Circling on Course:** Any form of circle or circles, whereby the horse crosses its original track between two consecutive obstacles anywhere on course, except to retake obstacle after refusal or run-out.
  - e. First disobedience anywhere on course - 3 faults.
  - f. Second cumulative disobedience anywhere on course - 6 faults.
3. **Eliminations.**
- a. Third cumulative disobedience anywhere on course.
  - b. Fall of horse and/or rider after the starting line and before the finish line.
  - c. Jumping an obstacle before it is reset, or without waiting for signal to proceed.
  - d. Starting before judges signal to proceed.
  - e. Failure to enter ring within one minute of being called.
  - f. Failure to cross the starting line within one minute after an audible signal to proceed.
  - g. Jumping an obstacle before crossing start line unless said obstacle is designed as a practice obstacle or after crossing the finish line, whether forming part of the course or not.
  - h. Off course.
  - i. Deliberately addressing an obstacle (penalized at any time the horse is in the ring).
  - j. Rider and/or horse leaving the arena before finishing the course (penalized at any time the horse is in the ring).
4. In cases of broken equipment the rider may either continue without penalty or stop and correct difficulty, in which case he will be penalized three faults. In case of loss of shoe, rider may either continue without penalty or be eliminated.

## SC-225. PLEASURE DRIVING

- A. **ATTIRE.** Exhibitor shall be neatly attired and wear long sleeves. A coat and tie of choice may be worn. All exhibitors shall wear a hat of choice. Exhibitor may wear rainwear or inclement weather apparel if weather conditions require. If female exhibitor is attired in short dress, a lap robe is required.
- B. **CART.** Horses shall compete in a pleasure driving class safely harnessed to a cart. The exhibitor shall be the only person permitted in such cart while the horse is being exhibited, and no pets shall be allowed in such cart during such exhibition. The cart shall be a pleasure type, two-wheeled, single-horse cart with seats for one or two persons. All carts must be basket type equipped. No stirrup type carts or sulkies will be allowed. Dash and basket cover optional.
- C. **EQUIPMENT.**
1. Equipment to be used shall include a whip suitable to the cart, light horse breast collar harness to include surcingle with shaft tie downs or quick hitch and crupper and standard bridle.
    - a. **Optional Equipment.** Blinders, overcheck or check reins, breeching or thimbles, running martingales, cavesson noseband may be used at the option of the exhibitor.
  2. **Bits.** See SC-200.A.3.&4. In addition, half cheek snaffle, liverpool, elbow driving and bradoon overcheck are also permitted. However, all mouthpieces must be a minimum of 5/16 inch (7.9mm) in diameter measured one inch from the cheek.
- D. **HOOVES AND SHOES.** Horses must be shown with natural hooves and standard shoes. No extended hooves, heavy shoes or toe weights allowed.
- E. **PROCEDURE.** Horses shall enter the ring in the same direction at a walk as directed by the announcer or ring steward. Each horse shall then be exhibited at the following gaits:
1. **Gaits.**
    - a. Walk.
    - b. Park Gait (normal trot)
    - c. Road Gait (faster, extended trot)
  2. **In the Ring.** Each horse shall demonstrate each of such gaits, in both directions of the ring, and at the direction of the ring steward. Such change of direction shall be accomplished by the horse crossing the ring at a walk or in a park gait only. Each horse shall also be required to demonstrate its ability to back readily and stand quietly. Excessive animation and speed will be penalized.
    - a. After all entries have finished their ring work and are lined up waiting to demonstrate the back, headers may quietly enter the ring and position themselves squarely two to three feet in front of the horse's head. Headers shall stand still with hands behind their back. Should it become necessary to restrain a horse prior to the completion of judging, the judge shall penalize that entry. Judges shall also penalize an entry whose head-

er disturbs or distracts any horse. Headers shall be neatly dressed in Western or English attire.

- F. **PLACINGS.** Placings for the class shall be determined by judging of each horse on the following basis:
1. Horse's ability to assure a pleasurable drive using the required skills.
  2. In the ready execution of the requirements stated in SC-225.E.2.

### SC-230. UTILITY DRIVING

A. **ATTIRE AND TACK .** See Pleasure Driving. Rule SC-225. A.- D.

B. **JUDGING PROCEDURE.**

1. **Tasks and Points.** This class will be judged on the performance of the horse through the tasks. The judge will assign a point value to each task and points will be added to or subtracted from this score based on the horse's performance through the task.
  - a. **Subtracting or Adding Points.** Points may be added or subtracted from a horse's total score on the tasks based on his attitude, manners, style and way of going. Manner of horse's way of going should demonstrate the general utility of the driving horse in everyday working situations.
2. **Negotiating Tasks.** Credit will be given to those horses that negotiate, in a continuous motion, the tasks cleanly, smoothly and alertly with style, in prompt response to the driver's cues. Excessive hesitation at a task shall be penalized.
3. **Faults, Touches and Disqualifications.** A horse with major faults, knock downs, refusals, etc., on the course will not be placed ahead of a horse that worked through the tasks cleanly. A horse should be penalized for touches of any element of the course and for unnecessary delay in approaching the tasks. A horse that is off course must be disqualified.

**Off course is defined as:**

- a. Taking a task in the wrong direction.
  - b. Negotiating a task from the wrong side.
  - c. Skipping a task unless directed by the judge.
  - d. Negotiating tasks in the wrong sequence.
4. **Backing.** The judge may ask the exhibitor to back the horse after completion of the course. However, if any exhibitor is asked to back, all exhibitors must be asked to back.

C. **COURSE REQUIREMENTS.**

1. **Number of Tasks.** The course will include a minimum of six and a maximum of eight tasks, selected from the list of tasks.
2. **Setting Up Tasks.** Care must be exercised to avoid the setting up of any of these tasks in a manner that may be hazardous to the horse or driver. All tasks not combined shall be a minimum of fifteen (15) feet (4.57m) apart.

3. **Course Design To Demonstrate Gaits.** The course shall be designed to require each horse to demonstrate walk, park gait and road gait somewhere between the tasks as part of the working course with enough space provided for the judge to evaluate the gaits. If the gait between tasks is not specifically listed on the course sheet, the gait used by the driver is optional.

#### D. TASKS.

1. **Animal hide.** Drive by an animal hide.
2. **Backthrough.** Shall consist of either two barrels, poles or pylons set a minimum of ten (10) feet (3m) apart.
3. **Box.** A three rail box of which the rails are a minimum of fifteen (15) feet (4.57m) long . Horse must be driven in, stopped, settled, then side passed out in either direction. Chalk lines may be substituted for rails. If task is elevated, then center height may not exceed ten (10) inches (25.4cm).
4. **Bridge.** A simulated bridge of two (2) rails with or without a floor, a minimum of ten (10) feet (3m) apart.
5. **Figure 8(s).** Two barrels, pylons or stands, about which the exhibitor must make the figure 8(s) in a forward motion: Walk obstacles minimum of ten (10) feet (3m) apart; park, trot and/or gait obstacles minimum of fifteen (15) feet (4.57m) apart.
6. **L-obstacle(s).** Poles placed in an “L” shape, through which the horse is driven at a walk. If rails are elevated, the maximum center height may not exceed ten (10) inches (25.4cm). The sides of the L shall not be less than twenty (20) feet (6.09m). See pattern below.

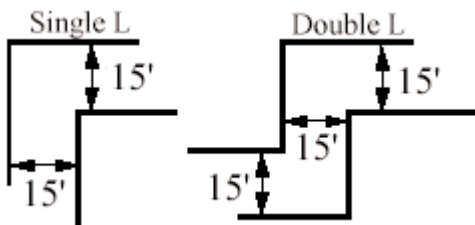

7. **Mailbox.** The mailbox must be set on a stand of four (4) feet (1.21m) minimum height. Exhibitor must open box, place card inside and close box.
8. **Road Sign.** Two road-type signs, a minimum of ten (10) feet (3m) apart, to be driven between.
9. **Serpentine.** Obstacle consisting of a minimum of 3 pylons; walk- pylons, minimum fifteen (15) feet (4.57m) apart, base to base; park trot to pylons, minimum twenty (20) feet (6.09m) apart, base to base.
10. **Sheep or Goat Pen.** Drive by.
11. **Simulated Water.** A plastic sheet secured to the ground so that it will not become affixed to the horse's foot when a horse passes over.
12. **Slicker.** When this obstacle is used, it will be so located that the driver can return it to a designated place. Reins must be held while doing so.

13. **Straight and Narrow.** Two parallel lines, one foot (30.48cm) apart, and a minimum of twenty-five (25) feet (7.62m) and maximum of fifty (50) feet (15.24m), consisting of either; garden hose, rope, minimum 1/2 inch (1.27cm) diameter, or chalk. Lines shall be of the same length and placement. Driver must keep one wheel between the lines for the entire length.
14. **Tack and Harness Check.** Driver to dismount from the cart and walk around the horse and cart while maintaining control of the horse and then remount while the horse is standing still.
15. **Twist.** Six (6) to eight (8) pylons which the driver shall maneuver around and through at a walk. The minimum distance between any two (2) pylons shall be ten (10) feet (3m). Suggested patterns, but not limited to: See patterns.

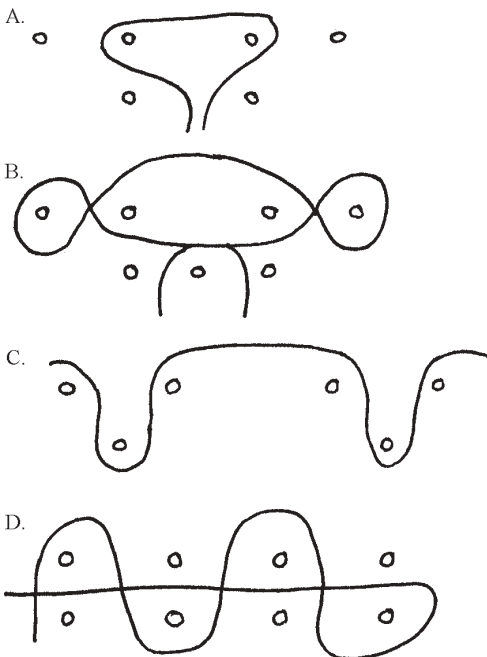

16. **U-Turn.** A three rail box of which the rails are a minimum of twenty (20) feet (6.09m) long, with a pylon located in the center of the opening of the box. The driver is to enter the box, drive around the pylon and exit the other side of the pylon. (See pattern below.)

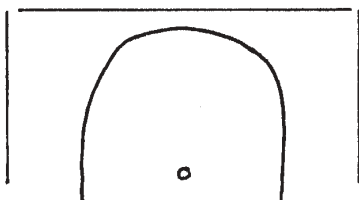

17. **Vehicles.** Two vehicles a minimum of fifteen (15) feet (4.57m) apart to be driven between.

### SC-235. WESTERN ATTIRE

- A. **REQUIRED ATTIRE.** In all western events, speed events and halter, it is mandatory to wear appropriate Western attire including long sleeves with collar (band, tuxedo, stand-up, etc.), western hat, and cowboy boots. The use of spurs, chaps, and hardhats are optional.
- B. Judges, at their discretion, may authorize adjustments to attire due to weather-related conditions.

### SC-240. WESTERN TACK

- A. **SADDLE, BRIDLE ETC.** Horses shall be shown with a western stock saddle (*leather or synthetic*) consisting of a horn, seat, pommel, cantle, skirt, fenders and western stirrups; silver equipment will not count over a good working outfit. Bridle may be either a standard plain or silver headstall with browband, shaped ear, or split ear.
1. **Optional.** The carrying of a rope or reata is optional.
  2. **Prohibited.** The use of a martingale, tiedown, noseband, chin strap narrower than 1/2 inch (1.27cm) or mechanical hackamore.
- B. **REINS.** Except in classes where noted, reins will be held in one hand and cannot be changed during performance. One hand to be around reins when romal type reins are used. When using a shank bit with split reins, only one finger permitted between the reins.
- C. **ROMAL.** Whenever this handbook refers to "Romal" it means an extension of braided material or smooth leather attached to closed reins.
1. This extension is to be allowed to be carried in the free hand with a 16 inch (40.64cm) spacing between the reining hand and free hand holding the Romal.
  2. The romal shall not be used forward of the cinch or used to signal or cue the horse in any way. Any infraction of this rule shall result in disqualification.
  3. When using romal reins, the rider's hand shall be around the reins with the wrists kept straight and relaxed, the thumb on top of the fingers closed lightly around the reins. When using a romal, no fingers between the reins are allowed. In reining and working cow horse (reined work) use of the free hand while holding the romal to alter the tension of length of the reins from the bridle to the hand is considered to be the use of two hands and a score of 0 will be applied except during the hesitation or settling of the horse.
- D. **HACKAMORE.** Junior horses being shown in a hackamore must be ridden with two hands on the reins. All hackamores will be made of braided rawhide, braided leather, or rope, and will be a maximum of 3/4 inch (1.9cm) at the cheek. There must be a minimum of 2 finger widths, approximately 1 1/2 inch (3.81cm), between the bosal and the nose. Absolutely no

metal under the jaw or on the noseband in connection with the bosal. Refer to rule SC-130.H.2.f.

1. **Reins.** The rider's hands should be carried near the pommel and not further than 4 inches (10.16cm) out on either side of the saddle horn with very limited movement. See illustration under Rule SC-245.B.4.

E. **SNAFFLE BIT.** Junior horses being shown in a snaffle bit must be ridden with two hands on the reins. Refer to rule JU-000.H.2.f.

1. **Snaffle Bit in Western Performance.** Whenever this rule book refers to a snaffle in western performance classes, it means conventional O-ring, egg-butt or D-ring, all with rings having an outside diameter no smaller than 2 inches (5.08cm), nor larger than 4 inches (10.16cm).

- a. **Bars.** Bars of mouthpiece must be round, smooth and unwrapped metal no less than 5/16 inch (7.9mm) in diameter measured one inch in from cheek with a gradual decrease to the center of the snaffle. May be inlaid, but smooth, or rubber latex wrapped. The mouthpiece may be two or three pieces.

- b. **Three Piece Mouthpiece.** If a mouthpiece is three pieces, a connecting ring must be no larger than 1 1/4 inches (3.17cm) in diameter, or a connecting flat bar must be no longer than 2 inches (5.08cm) and 3/8 inch (9.5mm) to 3/4 inch (1.9cm), measured top-to-bottom, and must lie flat in horse's mouth.

**Exception:** Three piece mouthpiece may not be used in SC-245.B.3., two-year-old Western Pleasure.

2. **Optional.** A loose curb, leather only, attached below the reins.
3. **Reins.** Split reins must be crossed. The rider's hands should be carried near the pommel and not further than 4 inches out on either side of the saddle horn with very limited movement. When split reins are used, they must be crossed and both hands must be on both reins. See illustration under Rule SC-245.B.4.

F. **BITS.** Horses being shown in a bit must use only one hand on the reins. Whenever this rule book refers to a bit in western performance classes, it means a curb bit that has a solid or broken mouthpiece, shanks, and acts with leverage. All curb bits must be free of mechanical devices and should be considered a standard western bit. A description of a legal, standard western bit includes: See diagram of legal bit.

1. **Shank.** Overall maximum shank length is 8 1/2 inches (21.59cm). Shank may be fixed or loose.
2. **Bar.** Bar of mouthpiece must be round, smooth and unwrapped metal of 5/16 inch (7.9mm) to 3/4 inch (1.9cm) in diameter measured one inch from cheek. It may be inlaid, but smooth, or rubber latex wrapped. Nothing, such as extensions or prongs, may protrude below the mouthpiece (bar). The mouthpiece may be two or three pieces .
3. **Three Piece Mouthpiece.** If it is three pieces, a connecting ring must be no larger than 1 1/4 inch (3.17cm) outside diameter, or a connecting flat bar must be no longer than 2

- inches (5.08cm) and 3/8 inch (9.5mm) to 3/4 inch (1.9cm), measured top-to-bottom, and must lie flat in horse's mouth.
4. **Standard.** Grazing, broken mouthpiece, half breeds and spades are standard; rollers and covers are permitted, but port must not be higher than 3 1/2 inches (8.89cm).
  5. **Prohibited.** Slip or gag bits, donut or flat polo mouthpieces are prohibited.
- G. **CHIN STRAPS.** Legal chin straps for curb bits may be leather or light chain, must be at least 1/2 inch (1.27cm) in width and lay flat against the jaw. A double chain that is welded together and acts as one chain is legal. The judge will have the right to disqualify any chin chains or leather straps he feels are too severe. When a curb bit is used, a curb strap or curb chain is required.

### Acceptable Chin Straps



- H. **JUDGE MAY PROHIBIT THE USE.** The judge may prohibit the use of bits and equipment he may consider too severe.
1. **Bits Physically or Mechanically Changed.** A bit cannot be physically or mechanically changed to increase the severity of its use and may be eliminated at the discretion of the judge.
  2. **Horse with Bloody Mouth.** In all divisions, if a horse's mouth is found to be bloody, disqualification is at the discretion of the judge.
- I. **DIAGRAM OF LEGAL BIT.** Acceptable Bits, Unacceptable Bits and Acceptable Curb Chain Chin Straps.

### Western Bits

#### Example of Acceptable bit; exception 2-year-olds

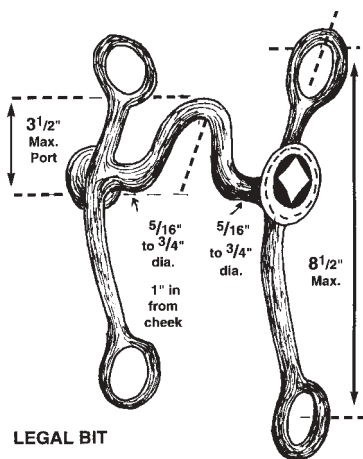

## Examples of Unacceptable Bits

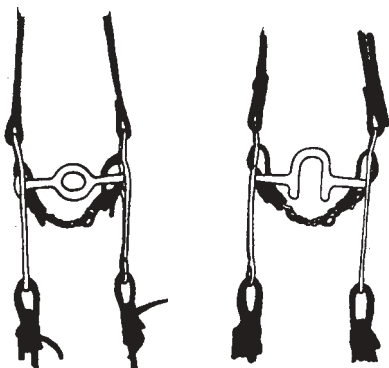

Donut Bit

Prong Bit

J. See equipment and attire chart in back of rule book.

## WESTERN ATTIRE AND TACK FOR ROPING, SPEED EVENTS, AND TEAM PENNING REFER TO RULE SC-270.

### SC-245. WESTERN PLEASURE

- A. **WESTERN ATTIRE AND TACK.** See rules SC-235 and SC-240.
- B. **THREE WESTERN PLEASURE CLASSES.** A show may have up to three approved western pleasure classes. If three Western pleasure classes are to be offered at a show, they shall be the following:
1. **Senior Western Pleasure,** six-year-old and older. All horses must be shown with a bit. See rule SC-240.F.
  2. **Junior Western Pleasure,** five-year-old and younger. Horses may be shown with either a snaffle bit, bit or hackamore at the discretion of the exhibitor. See rule SC-240.D.-F.
  3. **Two Year Old Western Pleasure.**
    - a. Horses shown in this class will not be eligible for any other open western pleasure class at the same show or contest. Three piece mouthpiece may not be used. SC-240.E.1.b.
    - b. Horses must be shown in a snaffle bit or hackamore with both hands on both reins. Split reins must be crossed. A macate is acceptable only with a bosal. Rider's hands should be carried near the pommel and not further than four (4) inches (10.16cm) out on either side of the saddle horn with very limited movement. When split reins are used, they must be crossed and both hands must be on both reins. See illustration for hand positions.
  4. **Acceptable and Not Acceptable Hand Positions.** When split reins are used, they must be crossed and both hands must be on both reins.

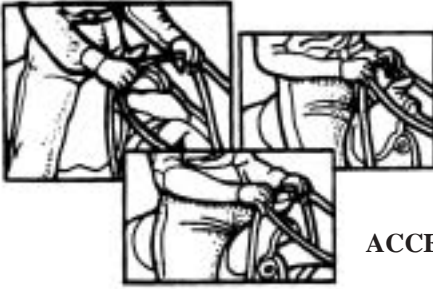

**ACCEPTABLE**

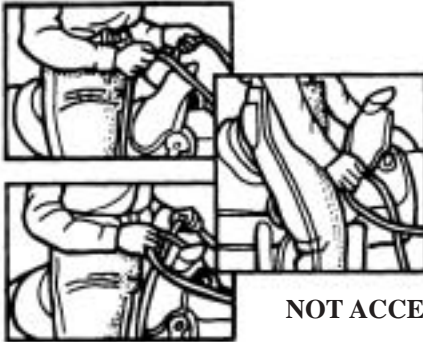

**NOT ACCEPTABLE**

- C. **TWO WESTERN PLEASURE CLASSES.** If two western pleasure classes are to be offered at a show they shall be the following:
1. **Senior Western Pleasure**, six-year-old and older. All horses must be shown with a bit. See SC-240.F.
  2. **Junior Western Pleasure**, five-year-old and younger. Horses may be shown with a snaffle bit, bit or hackamore at the discretion of the exhibitor. See rule SC-240.D.-F.
- D. **ONE WESTERN PLEASURE CLASS.** If only one western pleasure class is to be offered at a show, it shall be the following:
1. **Western Pleasure, All Ages.** Horses six years old and older must be shown with bit. Horses five years old and younger may be shown in snaffle bit, bit or hackamore. See rule SC-240.D.-F.
- E. **TERMINOLOGY.** The following terminology shall apply in all western classes whenever a specific gait is called for:
1. **Walk.** The walk is a natural, flat footed, four beat gait. The horse must move straight and true at the walk. The walk must be alert, with a stride of reasonable length in keeping with the size of the horse.
  2. **Jog Trot.** The jog trot is a smooth, ground covering two beat diagonal gait. The horse works from one pair of diagonals to the other pair. The jog trot should be square, bal-

anced with a straight forward movement of the feet. Horses walking with their back feet and trotting on the front are not considered performing the required gait. When asked to extend the jog, he moves out with the same smooth way of going.

3. **Lope.** The lope is an easy rhythmical three beat gait. Horses moving to the left should lope on the left lead. Horses moving to the right should lope on the right lead. Horses traveling at a four beat gait are not considered to be performing at a proper lope. The horse should lope with a natural stride and appear relaxed and smooth. He should be ridden at a speed that is a natural way of going. Judges will not ask exhibitor to extend the horses lope.
4. **Head.** The head should be carried at an angle that is natural and suitable to the horse's conformation at all gaits. Ideally, a horse should carry its head no lower than level and its nose should be in front of vertical. Below is an example of the ideal head set.

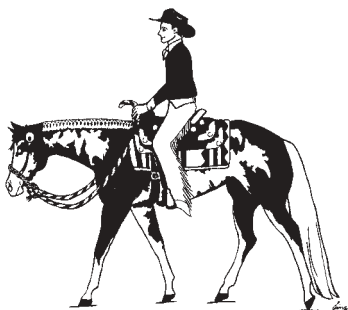

#### F. RING PROCEDURE.

1. **Walk, Trot and Lope.** Horses are to be shown at a walk, trot and lope on a reasonably loose rein without undue restraint. Horses must work both ways of the ring at all three gaits to demonstrate their ability with the different leads. A horse will not be penalized for passing. The judge shall have the right to ask for additional work from any horse. Judge may, at his discretion, back only the finalists.
2. **Reversing.** Horses are to be reversed to the inside, away from the rail. Horses may be required to reverse at a walk or a trot or may be required to go from any gait to any other gait at the discretion of the judge. Forward motion must be maintained. No contestant will be asked to reverse at a lope. In no event will a contestant be required to drop his reins or otherwise leave his horse unattended.
3. **Penalties.** The judge should penalize a horse's head position in western pleasure as severely as for a horse being on the wrong lead, excessive speed, bolting or bucking for the following faults:
  - a. **Head Position.** Horses that carry their heads such that the point of the ear is lower than the withers.
  - b. **Flexed.** Horses that are flexed behind the vertical.
  - c. **Slow Gait.** Horses that are excessively slow, at any

- gait.
- d. **Maintain Light Rein.** If light contact with reasonably loose rein is not maintained.
  - e. **Appearance.** Horses that appear sullen, dull, lethargic or emaciated.
  - f. **Maintain Forward Motion.** Horses which fail to maintain forward motion while walking, trotting, loping or reversing.
  - g. **Failing to Take Gait.** Horses which fail to take the gait when called for.
- G. **FREE HAND.** The free hand shall not be used to support the rider by being placed on any part of the saddle.
- H. **JUDGED ON PERFORMANCE ONLY.** This class will be judged on performance only. Conformation is not to be considered by the judge.

### SC-250. TRAIL

- A. **WESTERN ATTIRE AND TACK.** See rule SC-235. & SC-240.
- B. **JUDGING PROCEDURE.**
1. **Judged on Performance.** This class will be judged on the performance of the horse over the obstacles. Judges will assign a point value to each obstacle and points will be added to or subtracted from this score based on the horse's performance over that obstacle.
  2. **Credit Given.** Credit will be given to those horses negotiating the obstacles cleanly, smoothly, and alertly with style in prompt response to the rider's cues.
  3. **Horses Should Be Penalized For Any of the Following:**
    - a. Any horse performing with an artificial or mechanical appearance should be penalized.
    - b. Horses should be penalized for touches and knock downs of any elements of the course and for unnecessary delay in approaching the obstacles.
    - c. Extreme variation of gait is to be penalized.
  4. **Maneuvering The Course.**
    - a. **Gaits:** The course must be designed to require each horse to demonstrate walk, trot and lope somewhere between the obstacles as part of the working course. Enough space must be provided for the judge to evaluate the gaits. The horse's way of going should be appropriate for a trail horse. A lead change does not constitute an obstacle and should be considered when scoring gaits.
    - b. **Add or Subtract Points.** Points may be added or subtracted from a horse's total score on the obstacles based on his attitude, manners, style, and way of going, manner of travel.
    - c. **Major Fault.** A horse with a major fault on the course, knock downs, etc., should not place ahead of a horse that worked the obstacles cleanly.
- C. **COURSE REQUIREMENTS.**
1. **Use Care In Setting Up Course.** Care must be exercised to avoid the setting up of any of these obstacles in a man-

ner that may be hazardous to the horse or rider. Obstacles not combined shall be a minimum of nine feet (2.74m) apart.

2. **Change of Procedure.** Where the local conditions and equipment will not permit the establishment of obstacles as specified and that they may require changing of procedures of hand on the reins, then all competitors must be advised that such changing of procedure or of hands is permitted.

#### D. EXHIBITOR REQUIREMENTS.

1. Exhibitor must use only one hand on the reins and may not be changed except when: Exception Rule SC-240 D.& E.,
  - a. Putting on or removing slicker.
  - b. Carrying an object from one part of arena to another.
  - c. Dismounting.

E. **OBSTACLE REQUIREMENTS.** Course will include a minimum of 6 and a maximum of 10 obstacles and must be designed using *at least one* obstacle from each of the following divisions.

#### Division A.

1. **Walk-overs.** An obstacle of a least four poles measuring 20 inches (50.8cm) to 24 inches (60.96cm) \*between poles, either on the ground or raised with a maximum center height of 10 inches (25.4cm). These can be in a straight line, curved or zigzag.
2. **Trot-overs.** An obstacle of at least four poles measuring 36 inches to 42 inches (91.44-106.68cm) \*between poles, either on the ground or raised with a maximum center height of 10 inches (25.4cm). These can be in a straight line, curved or zigzag.
3. **Lope-overs.** An obstacle of at least four poles, measuring 6' (1.82m) to 7' (2.13m) \*between poles, either on the ground or raised with a maximum center height of 12 inches (30.48cm). These can be in a straight line, curved or zigzag.

**\*NOTE:** A curved or zigzag design is measured for distance between the poles, from center of the length of the pole to the center of the length of the next pole.

4. **Jump.**
  - a. An obstacle designed for horses to be ridden over, either:
    1. **Single Jump.** An obstacle whose center height is not less than 14 inches (35.56cm) high or more than 24 inches (60.96cm) high; or,
    2. **Multiple Jump.** Obstacles with a maximum center height of 18 inches (45.72cm) high.
  - b. The saddlehorn may be held during the execution of this obstacle only.

#### Division B.

1. **Side-pass.** An Object of such nature and length which is safe may be used to demonstrate the responsiveness of the horse to leg signals. If raised, height may not exceed 12 inches (30.48cm). The obstacle may be designed to require the horse to side pass either or both ways or in a pattern. Objects such as a bale of hay that may become entangled in

- a horse's feet or legs will not be used.
2. **Lime Circle.** Requiring either:
    - a. Turn on the forehand with front feet inside and back feet turning on outside of circle; or
    - b. Turn on the haunches with hind feet inside and front feet on outside of circle.
  3. **Square, minimum 6' (1.82m) sides.** Ride into the square. While all four feet are confined in the square, make a 360 degree turn and ride out.
  4. **Gate.** The gate must be set up so that it is a minimum of four feet (1.21m) in length and four feet (1.21m) in height and so that the exhibitor can open from his right or left side. It is permissible to change hands prior to opening gate if the gate is in such a position as to justify the change of hands on the reins. Riders losing control of the gate while passing through shall be penalized and scored accordingly.

#### **Division C.**

1. **Back through.** Shall consist of either:
  - a. **Poles.** Straight L, double L,V,U or similar shaped obstacle. On ground, 30 inches (76.2cm) between minimum; elevated, 32 inches (81.28cm) between minimum elevated height not to exceed 12 inches (30.48cm).
  - b. **Barrels or Cones, minimum of three.** 36 inches (91.44cm) between minimum.
  - c. **Triangle.** 36 inches (91.44cm) between minimum at entry and 40 inches (101.6cm) between minimum for sides. If guardrails are used with b. or c. they shall be 3 to 4 feet (.91m-1.21m) from the sides of the obstacle.
2. **Bridge.** A Bridge with a wooden floor not to exceed 12 inches (30.48cm) in height and with or without side rails not less than 36 inches (91.44cm) apart will be used. A log placed under the bridge to create a teeter-totter effect is not prohibited so long as it is secured to the bridge so as not to shift during the passage of the horse over the bridge.
3. **Water Hazard.** A ditch or shallow pond of water may be used. A horse must pass through this obstacle, which must be large enough so that to properly complete this obstacle all four feet of the horse must step in the water. Management may not place any item in the water. If a box is used, simulated water is permissible. If the water box is used preceding and in combination with a bridge, simulated water must be used.
4. **Simulated Water.** A plastic sheet, secured to the ground, so that it will not become affixed to the horse's foot when a horse passes over the simulated water.

#### **Division D.**

1. **Carrying Object.** Any object, other than animal or fowl, and of a reasonable size or weight, may be carried to a specific point.
2. **Drag or Pull.** Any object other than animal or fowl which can reasonably be pulled or dragged without the exhibitor having to dally may be used. Dallying shall be at the option of the exhibitor.

3. **Slicker.** When this obstacle is used, it will be so located that the exhibitor can ride to the slicker, put it on and remove it and return it to a designated place. Reins may be held or dropped on the neck of the horse or over the saddle horn while so doing.
4. **Mailbox.** Remove and/or replace items. Side pass is optional.
5. **Animal Hide.** Either ride over or next to an animal hide.
6. **Ground Tie.** Ride or proceed to the designated place, dismount and either hobble or ground tie the horse and move away from the horse a reasonable distance to clearly show the proper training of the horse. To ground tie, reins shall be as follows.
  - a. Split, drop the reins.
  - b. Romal, remove reins over head of horse, unclip off rein and drop.
  - c. Hackamore, drop lead.
7. **Serpentine.** Obstacle consisting of four pylons, guardrails optional, through which a horse will maneuver at a walk or jog-trot. Guardrails shall consist of poles placed parallel and a minimum of 3 feet (.91m) from the side of pylons; walk-pylons, minimum 3 feet (.91m) apart, base to base. Jog-trot pylons, minimum 6 feet (1.82m) apart, base to base.
8. **Jog-around.** Square consisting of 4 poles, minimum 12 feet (3.65m) long, and a pylon placed in the center of the square. Exhibitor will enter over a designated pole, perform a minimum 90 degree jog around the pylon and exit over the designated pole.
9. **Jog-through.** Shall consist of:
  - a. **Poles.** L, double L,V,U or similar shaped obstacle. On ground, 3 feet (.91m) minimum and 4 feet (1.21m) maximum; elevated, 3 feet 3 inches (.99m) between minimum and 4 feet 3 inches (1.29m) maximum. Elevated height shall not exceed 12 inches (30.48cm).

## SC-255. WESTERN RIDING

- A. **WESTERN ATTIRE AND TACK.** See rules SC-235. and SC-240. **Exception.** Leg wraps and/or boots optional at rider's discretion. *See page 298 for legend for the following patterns (diagrams).*
- B. Western Riding is an event where the horse is judged on quality of gaits, flying lead changes at the lope, response to the rider, manners and disposition. The horse should perform with reasonable speed, and be sensible, well-mannered, free and easy-moving.
- C. Credit shall be given for and emphasis placed on smoothness, even cadence of gait (i.e., starting and finishing pattern with the same cadence), and the horse's ability to perform flying lead changes precisely, easily and simultaneously both hind and front at the center point between markers. The horse should have a relaxed head carriage showing response to the rider's hands, with a moderate flexion at the poll. Horses may be ridden with light contact or on a reasonable loose rein. The horse

should cross the log both at the jog and the lope without breaking gait or radically changing stride.

- D. The judge will select one of the *four* patterns to be performed. The judge is responsible for the pattern being correctly set.
- E. On the pattern:
1. The eight small circles represent pylon markers which are recommended. These should be separated by a uniform measured distance of not less than 30 feet (9.14m) nor more than 50 feet (15.24m) on the sides with 5 markers. In pattern one, the three markers on the opposite side should be set adjacent to the appropriate markers. It is recommended that markers be set a minimum of 15 feet (4.57m) from the fence and with 50- to 80-foot (15.24-24.38m) width in the pattern, as the arena permits.
  2. A solid log or pole should be used and be a minimum of 8 feet (2.43m) in length.
  3. The long serpentine line indicates the direction of travel and gaits at which the horse is to move. The recommended lead changing point is equal to 1/2 stride length before or after the center point between the markers. The dotted line (...) indicates walk, the dash line (---) jog, and the solid line (\_\_\_\_) lope.
- F. Scoring will be on a basis of 0-100 with 70 denoting an average performance.
1. Scoring guidelines to be considered; points will be added or subtracted from the maneuvers on the following basis, ranging from plus 1.5, to minus 1.5: -1.5 extremely poor, -1 very poor, -.5 poor, 0 average, +.5 good, +1 very good, +1.5 excellent. Maneuver scores are to be determined independently of penalty points.
- G. A contestant shall be penalized each time the following occur:
1. Five (5) points:
    - a. Out of lead beyond the next designated change area (note: failures to change, including cross-cantering, at two consecutive change areas would result in 10 penalty points).
    - b. Kicking out.
    - c. Blatant disobedience.
  2. Three (3) points:
    - a. Not performing the specific gait (jog or lope) or stopping when called for in the pattern, within 10 feet (3m) of the designated area.
    - b. Break of gait at the lope.
    - c. Simple change of leads, up to three.
    - d. Out of lead prior to the designated change from the cone to the previous change area or out of lead after the designated change from the cone to the next designated change area.
    - e. Additional lead changes anywhere in pattern (except when correcting an extra change or incorrect lead departure).
    - f. In pattern one, failure to start the lope within 30 feet (9.14m) after crossing the log at the jog.
    - g. Break of gait at walk or jog for two or more strides.

3. One (1) point:
    - a. Break of gait at walk or jog up to two strides.
    - b. Hitting or rolling log.
    - c. Out of lead for more than 1 stride *either side of the center point and between the markers.*
    - d. Splitting the log (log between the two front or two hind feet) at the lope.
  4. One-half (1/2) point:
    - a. Tick or light touch of log.
    - b. Hind legs skipping or coming together during lead change.
    - c. *Non-simultaneous lead change (front to hind or hind to front).*
  5. Disqualified – 0 score
    - a. Fall to ground by horse or rider.
    - b. Illegal equipment.
    - c. Willful abuse.
    - d. Off course.
    - e. Knocking over markers.
    - f. Completely missing log.
    - g. Major refusal – stop and back more than 2 strides or 4 steps with front legs.
    - h. Major disobedience – rearing, schooling.
    - i. Failure to start lope prior to end cone in pattern #1.
    - j. Upon execution of 4 simple lead changes (defined as a stop or hesitation of forward motion) *and/or failure to change leads.*
  6. Credits:
    - a. Change of leads, hind and front simultaneously.
    - b. Changes of designated point.
    - c. Accurate and smooth pattern.
    - d. Even pace throughout.
    - e. Easy to guide and control with rein and leg.
    - f. Manners and disposition.
    - g. Conformation and fitness.
- H The following characteristics are considered faults and should be judged accordingly in maneuver scores.
1. Opening mouth excessively.
  2. Anticipating signals or early lead changes.
  3. Stumbling.



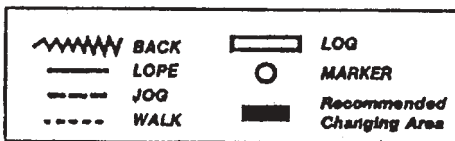
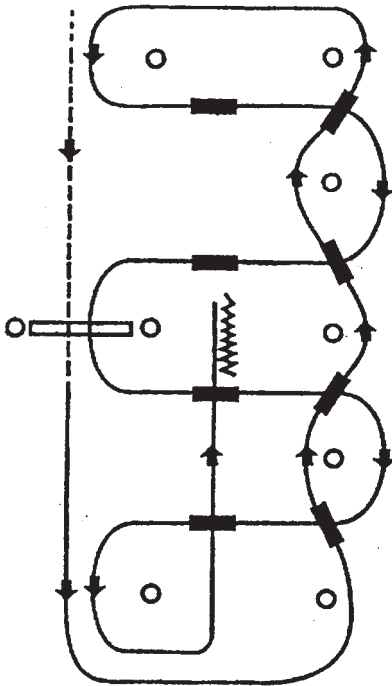



WESTERN RIDING PATTERN #1.

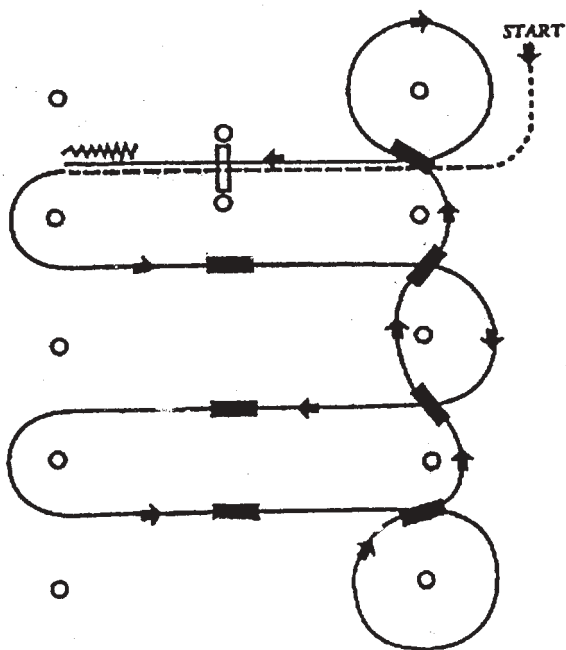

1. Walk and jog over log.
2. Transition to lope and lope around end.
3. First line change.
4. Second line change.
5. Third line change.
6. Fourth line change and lope around the end of arena.
7. First crossing change.
8. Second crossing change.
9. Lope over log.
10. Third crossing change.
11. Fourth crossing change.
12. Lope up the center, stop and back.

WESTERN RIDING PATTERN #2.



	<b>BACK</b>		<b>LOG</b>
	<b>LOPE</b>		<b>MARKER</b>
	<b>JOG</b>		<b>Recommended Changing Area</b>
	<b>WALK</b>		

1. Walk, transition to jog, jog over log.
2. Transition to lope.
3. First crossing change.
4. Second crossing change.
5. Third crossing change.
6. Circle and first line change.
7. Second line change.
8. Third line change.
9. Fourth line change and circle.
10. Lope log.
11. Lope, stop and back.



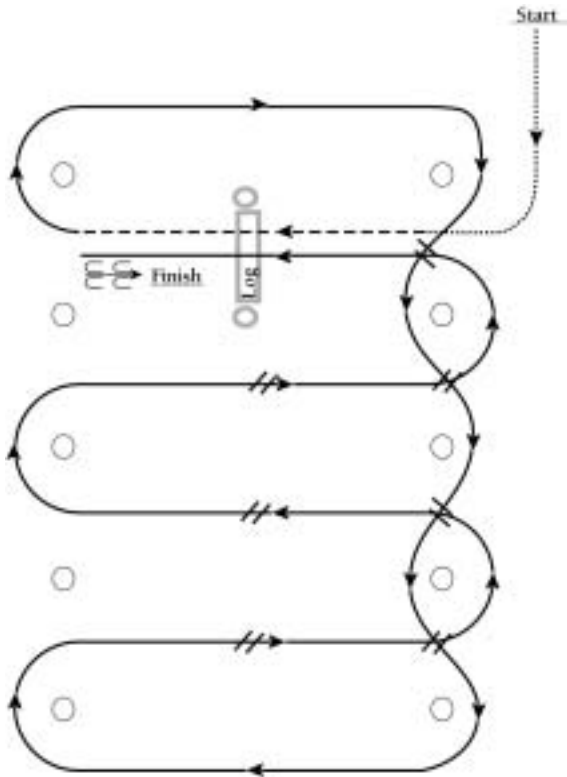

1. Walk, transition to jog, jog over log.
2. Transition to right.
3. First line change.
4. Second line change.
5. Third line change.
6. Fourth line change.
7. First crossing change.
8. Second crossing change.
9. Third crossing change.
10. Lope over log.
11. Lope, stop & back.

## SC-260. REINING

- A. **WESTERN ATTIRE AND TACK.** See Rules SC-235 and SC-240. **Exception.** Leg wraps and/or boots optional at rider's discretion. *See page 298 for legend for the following patterns (diagrams).*
1. **Chain Curbs.** Chain curbs are permissible but must be at least one-half inch in width, cannot be twisted, and must meet the approval of the judge.
- B. Any one of the nine APHA approved reining patterns may be used and is to be selected by the judge of the class and used by all contestants in the class. (Refer to YP-125 for youth patterns.)
- C. Each contestant will perform the required pattern individually and separately. All horses will be judged immediately upon entering the arena and judging will cease after the last maneuver. Any fault incurred prior to the commencement of a pattern will be scored accordingly.
- D. To rein a horse is not only to guide him, but also to control his every movement. The best reined horse should be willfully guided or controlled with little or no apparent resistance and dictated to completely. Any movement on his own must be considered a lack of control. All deviations from the exact written pattern must be considered a lack of or temporary loss of control, and therefore a fault that must be marked down according to severity of deviation. After deducting all faults, set here within, against execution of the pattern and the horse's overall performance, credit should be given for smoothness, finesse, attitude, quickness and authority of performing various maneuvers, while using controlled speed which raises the difficulty level and makes him more exciting and pleasing to watch to an audience.
- E. **SCORING.** The scoring will be on the basis of 0-infinity, with 70 denoting an average performance. The individual maneuvers are scored in 1/2 point increments from a low of -1 1/2 to a high of +1 1/2 with a score of 0 denoting a maneuver that is correct with no degree of difficulty.
- F. The following will result in no score:
1. Abuse of an animal in the show arena and/or evidence that an act of abuse has occurred prior to or during the exhibition of a horse in competition;
  2. Use of illegal equipment, including wire on bits, bosals or curb chains;
  3. Use of illegal bits, bosals or curb chains;
  4. Use of tack collars, tie downs or nose bands;
  5. Use of whips or bats;
  6. Use of any attachment which alters the movement of or circulation to the tail;
  7. Failure to dismount and/or present horse and equipment to the appropriate judge for inspection if requested by the judge;
  8. Disrespect or misconduct by the exhibitor.
  9. The judge(s) may excuse a horse at any time while in the arena for unsafe conditions or improper exhibition pertaining to both the horse and/or rider.

- G. Excess rein may be straightened at any place a horse is allowed to be completely stopped during a pattern. When using a romal, no fingers between the reins are allowed. The free hand may be used to hold the romal provided it is held at least 16" from the reining hand and in a relaxed position. Use of the free hand while holding the romal to alter the tension or length of the reins from the bridle to the reining hand is considered to be the use of two hands, and a score of 0 will be applied.
- H. The following will result in a score of 0:
1. Use of more than index or first finger between reins;
  2. Use of two hands (exception in snaffle bit or hackamore classes designated for two hands) or changing hands;
  3. Use of romal other than as outlined in SC-240.C.;
  4. Failure to complete pattern as written;
  5. Performing the maneuvers other than in specified order;
  6. The inclusion of maneuvers not specified, including, but not limited to;
    - a. Backing more than two strides,
    - b. Turning more than 90 degrees, Exception: a complete stop in the 1st quarter of a circle after a canter departure is not to be considered an inclusion of maneuver; a 2 point break of gait penalty will apply.
  7. Equipment failure that delays completion of pattern including dropping a rein that contacts the ground while the horse is in motion;
  8. Balking or refusal of command where pattern is delayed;
  9. Running away or failing to guide where it becomes impossible to discern whether the entry is on pattern;
  10. Jogging in excess of one-half circle or one-half the length of the arena;
  11. Overspins of more than 1/4 turn;
  12. Fall to the ground by horse or rider.
- I. The following will result in a penalty of five (5) points:
1. Spurring in front of cinch;
  2. Use of either hand to instill fear or praise;
  3. Holding saddle with either hand;
  4. Blatant disobedience including kicking, biting, bucking, rearing and striking.
- J. The following will result in a two (2) point penalty:
1. Break of gait;
  2. Freeze up in spins or rollbacks;
  3. On walk-in patterns, failure to stop or walk before executing a canter departure;
  4. On run-in patterns, failure to be in a canter prior to reaching the first marker.
  5. If a horse does not completely pass the specified marker before initiating a stop position.
- K. Starting or performing circles or eights out of lead will be judged as follows:
1. Each time a horse is out of lead, a judge is required to deduct one point. The penalty for being out of lead is accumulative and the judge will deduct one penalty point for each quarter of the circumference of a circle or any part thereof that a horse is out of lead.

2. A judge is required to penalize a horse 1/2 point for a delayed change of lead by one stride.
- L. Deduct 1/2 point for starting circle at a jog or exiting rollbacks at a jog up to 2 strides. Jogging beyond two strides, but less than 1/2 circle or 1/2 length of the arena, deduct 2 points.
- M. Deduct 1/2 point for over or under spinning up to 1/8 of a turn; deduct 1 point for over or under spinning up to 1/4 of a turn.
- N. In patterns requiring a run-around, failure to be on the correct lead when rounding the end of the arena will be penalized as follows: for 1/2 the turn or less, 1 point; for more than 1/2 turn, 2 points.
- O. There will be a 1/2 point penalty for failure to remain a minimum of 20 feet from wall or fence when approaching a stop and/or rollback.
- P. A judge may require any contestant to repeat his performance of any or all of the various parts of the pattern.
- Q. Faults against the horse to be scored accordingly, but not to cause disqualification:
  1. Opening mouth excessively when wearing bit;
  2. Excessive jawing, opening mouth, or head-raising on stop;
  3. Lack of smooth, straight stop on haunches – bouncing or sideways stop;
  4. Refusing to change leads;
  5. Anticipating signals;
  6. Stumbling;
  7. Backing sideways;
  8. Knocking over markers.
- R. Faults against the rider to be scored accordingly, but not to cause disqualification:
  1. Losing stirrup;
  2. Any unnecessary aid given by the rider such as unnecessary talking, petting, spurring, quirting, jerking of reins, etc.;
  3. Failure to run circles or figure eight within the markers is not considered a fault.
- S. A show may have up to three approved reining classes.
  1. If three reining classes are to be held at a show, they shall be the following:
    - a. Senior Reining shown with bit;
    - b. Junior Reining shown with bit;
    - c. Hackamore/Snaffle Bit Reining (5-year-old and younger, shown with hackamore or snaffle bit):
      1. No horse may be entered in both junior bit and hackamore/snaffle bit reining classes at the same show.
  2. If two reining classes are to be held at a show, they shall be the following:
    - a. Senior Reining shown with bit;
    - b. Junior Reining shown with either bit, hackamore or snaffle bit at the discretion of the exhibitor;
  3. If only one reining class is to be held at a show, it shall be the following:
    - a. Reining all-ages, 6-year-old and older must be shown in bit; horses 5-years-old and younger may be shown in



## Reining Pattern #2.

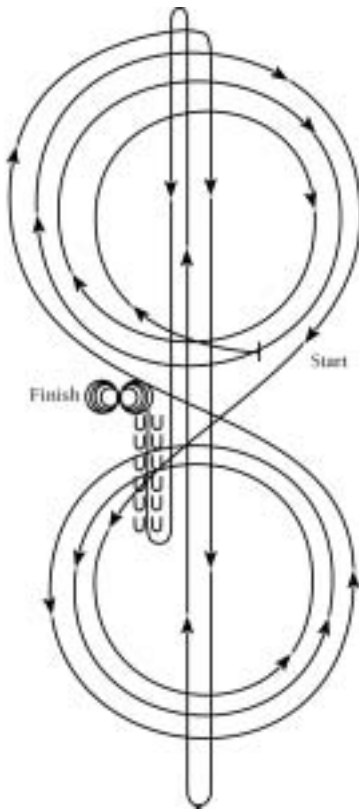

Horses may walk or trot to the center of the arena. Beginning at the center of the arena facing the left wall or fence.

1. Beginning on the right lead, complete three circles to the right; the first circle small and slow; the next two circles large and fast. Change leads at the center of the arena.
2. Complete three circles to the left; the first circle small and slow; the next two circles large and fast. Change leads at the center of the arena.
3. Continue around previous circle to the right. At the top of the circle, run down the middle to the far end of the arena past the end marker and do a right rollback - no hesitation.
4. Run up the middle to the opposite end of the arena past the end marker and do a left rollback - no hesitation.
5. Run past the center marker and do a sliding stop. Back up to the center of the arena or at least ten feet(3m). Hesitate.
6. Complete four spins to the right.
7. Complete four spins to the left. Hesitate to demonstrate the completion of the pattern.

Rider may dismount and drop bridle to the designated judge.

### Reining Pattern #3.

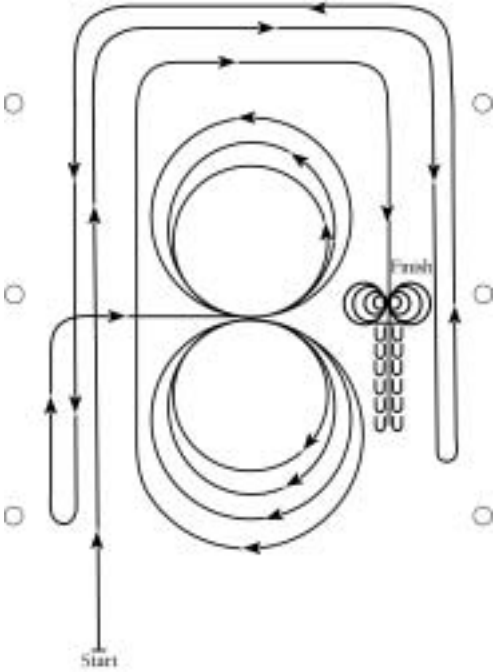

1. Beginning and staying at least twenty feet (6.09m) from the walls or fence, lope straight up the left side of the arena, circle the top end of the arena, run straight down the opposite or right side of the arena past the center marker and do a left rollback – no hesitation.
  2. Continue straight up the right side of the arena staying at least twenty feet from the walls or fence, circle back around the top of the arena, run straight down the left side of the arena past the center marker and do a right rollback – no hesitation.
  3. Continue up the left side of the arena to the center marker. At the center marker, the horse should be on the right lead. Guide the horse to the center of the arena on the right lead and complete three circles to the right: the first two circles large and fast; the third circle small and slow. Change leads at the center of the arena.
  4. Complete three circles to the left: the first two circles large and fast; the third circle small and slow. Change leads in the center of the arena.
  5. Begin a large fast circle to the right but do not close this circle. Continue up the left side of the arena staying at least twenty feet from the walls or fence, circle the top of the arena, run straight down the opposite or right side of the arena past the center marker and do a sliding stop. Back up at least ten feet (3m). Hesitate.
  6. Complete four spins to the right.
  7. Complete four spins to the left. Hesitate to demonstrate completion of the pattern.
- Rider may dismount and drop bridle to the designated judge.

## Reining Pattern #4.

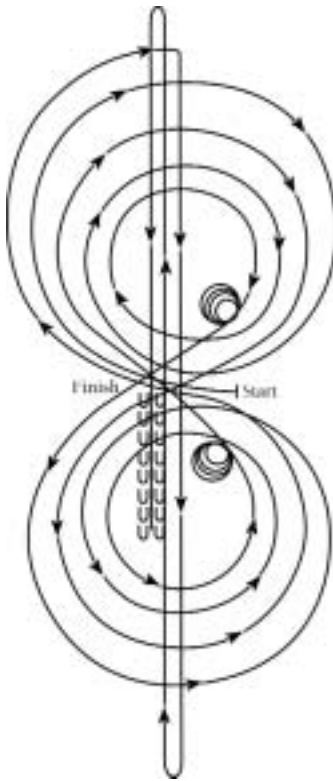

Horses may walk or trot to the center of the arena. Beginning at the center of the arena facing the left wall or fence.

1. Beginning on the right lead, complete three circles to the right: the first two circles large and fast; the third circle small and slow. Stop at the center of the arena.
2. Complete four spins to the right. Hesitate.
3. Beginning on the left lead, complete three circles to the left: the first two circles large and fast; the third circle small and slow. Stop at the center of the arena.
4. Complete four spins to the left. Hesitate.
5. Beginning on the right lead, run a large fast circle to the right, change leads at the center of the arena, run a large fast circle to the left, and change leads at the center of the arena.
6. *Continue around previous circle to the right. At the top of the circle, run down the middle to the far end of the arena past the end marker and do a right rollback - no hesitation.*
7. *Run up the middle to the opposite end of the arena past the end marker and do a left rollback - no hesitation.*
8. *Run past the center marker and do a sliding stop. Back up to the center of the arena or at least ten feet. Hesitate to demonstrate completion of the pattern.*

Rider may dismount and drop bridle to the designated judge.

## Reining Pattern #5.

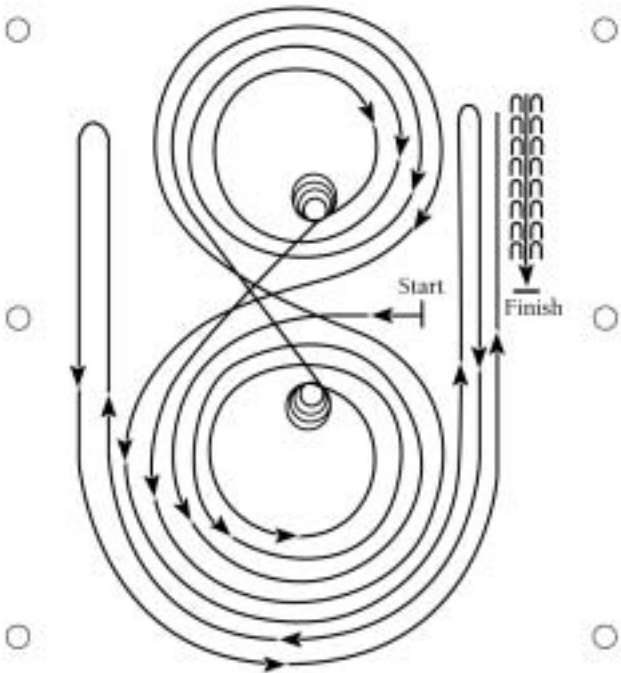

Horses may walk or trot to the center of the arena. Beginning at the center of the arena facing the left wall or fence.

1. Beginning on the left lead, complete three circles to the left: the first two circles large and fast; the third circle small and slow. Stop at the center of the arena.
2. Complete four spins to the left. Hesitate.
3. Beginning on the right lead, complete three circles to the right: the first two circles large and fast; the third circle small and slow. Stop at the center of the arena.
4. Complete four spins to the right. Hesitate.
5. Beginning on the left lead, run a large fast circle to the left, change leads at the center of the arena, run a large fast circle to the right, and change leads at the center of the arena.
6. Continue around previous circle to the left but do not close this circle. Run up the right side of the arena past the center marker and do a right rollback at least twenty feet (6.09m) from the wall or fence – no hesitation.
7. Continue around previous circle but do not close this circle. Run up the left side of the arena past the center marker and do a left rollback at least twenty feet (6.09m) from the wall or fence – no hesitation.
8. Continue back around previous circle but do not close this circle. Run up the right side of the arena past the center marker and do a sliding stop at least twenty feet (6.09m) from the wall or fence. Back up at least ten feet (3m). Hesitate to demonstrate completion of the pattern.

Rider may dismount and drop bridle to the designated judge.

## Reining Pattern #6.

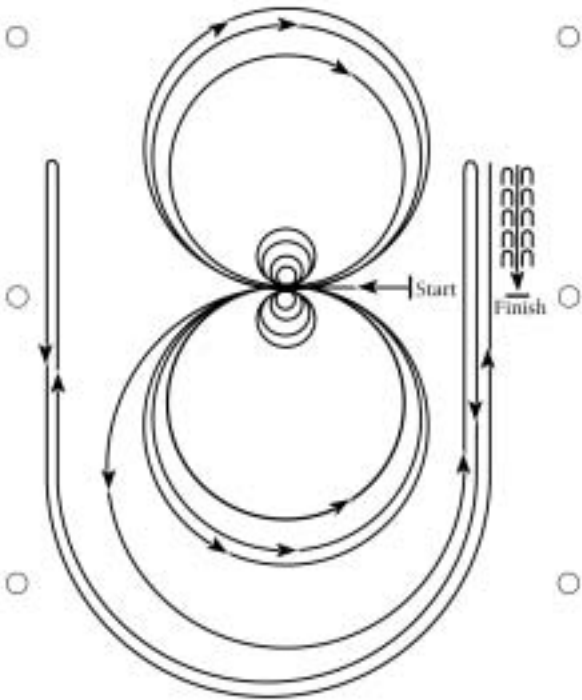

Horses may walk or trot to the center of the arena. Beginning at the center of the arena facing the left wall or fence.

1. Complete four spins to the right.
2. Complete four spins to the left. Hesitate.
3. Beginning on the left lead, complete three circles to the left: the first two circles large and fast; the third circle small and slow. Change leads at the center of the arena.
4. Complete three circles to the right: the first two circles large and fast; the third circle small and slow. Change leads at the center of the arena.
5. Begin a large, fast circle to the left but do not close this circle. Run up the right side of the arena past the center marker and do a right rollback at least twenty feet (6.09m) from the wall or fence – no hesitation.
6. Continue back around previous circle but do not close this circle. Run up the left side of the arena past the center marker and do a left rollback at least twenty feet (6.09m) from the wall or fence – no hesitation.
7. Continue back around previous circle but do not close this circle. Run up the right side of the arena past the center marker and do a sliding stop at least twenty feet (6.09m) from the wall or fence. Back up at least ten feet (3m). Hesitate to demonstrate the completion of the pattern.

Rider may dismount and drop bridle to the designated judge.

## Reining Pattern #7.

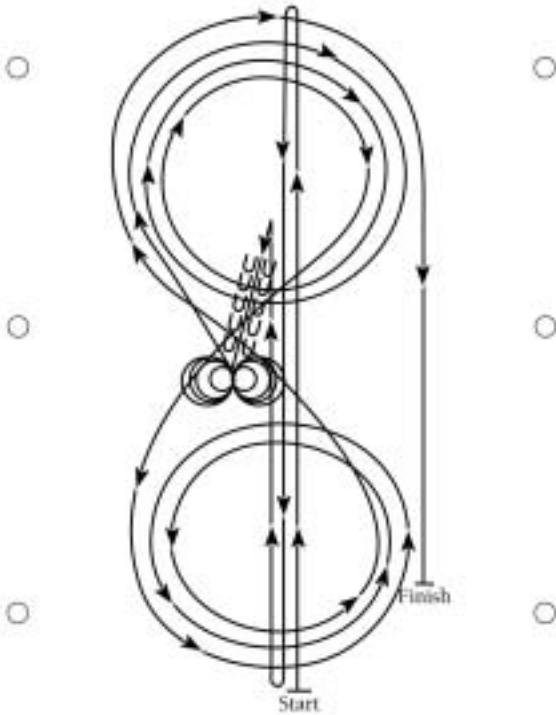

1. Run at speed to the far end of the arena past the end marker and do a left rollback – no hesitation.
2. Run to the opposite end of the arena past the end marker and do a right rollback – no hesitation.
3. Run past the center marker and do a sliding stop. Back up to the center of the arena at least ten feet (3m). Hesitate.
4. Complete four spins to the right.
5. Complete four and one-quarter spins to the left so that horse is facing left wall or fence. Hesitate.
6. Beginning on the right lead, complete three circles to the right: the first two circles large and fast; the third circle small and slow. Change leads at the center of the arena.
7. Complete three circles to the left: the first two circles large and fast; the third circle small and slow. Change leads at the center of the arena.
8. Begin a large fast circle to the right but do not close this circle. Run straight down the right side of the arena past the center marker and do a sliding stop at least twenty feet (6.09m) from the wall or fence. Hesitate to demonstrate completion of the pattern.

Rider may dismount and drop bridle to the designated judge.

## Reining Pattern #8.

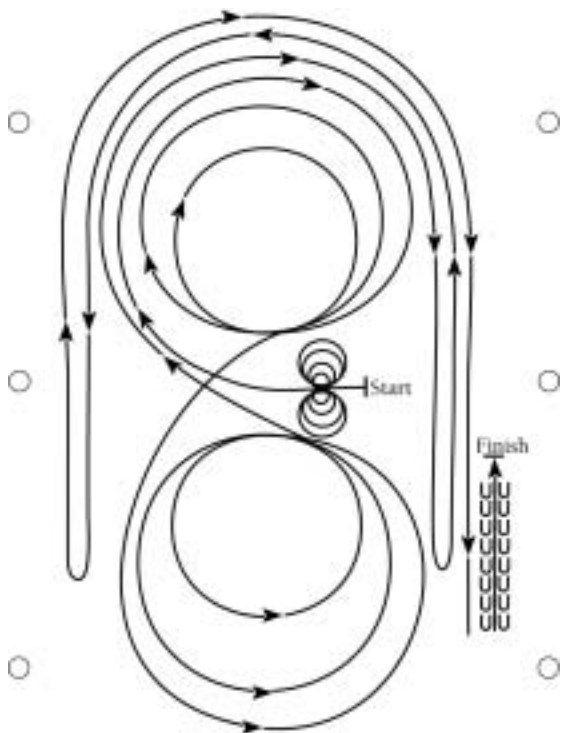

Horses may walk or trot to the center of the arena. Beginning at the center of the arena facing the left wall or fence.

1. Complete four spins to the left.
2. Complete four spins to the right. Hesitate.
3. Beginning on the right lead, complete three circles to the right: the first circle large and fast; the second circle small and slow; the third circle large and fast. Change leads at the center of the arena.
4. Complete three circles to the left: the first circle large and fast; the second circle small and slow; the third circle large and fast. Change leads at the center of the arena.
5. Begin a large fast circle to the right but do not close this circle. Run straight down the right side of the arena past the center marker and do a left rollback at least twenty feet (6.09m) from the wall or fence – no hesitation.
6. Continue back around the previous circle but do not close this circle. Run down the left side of the arena past the center marker and do a right rollback at least twenty feet (6.09m) from the wall or fence – no hesitation.
7. Continue back around the previous circle but do not close this circle. Run down the right side of the arena past the center marker and do a sliding stop at least twenty feet (6.09m) from the wall or fence. Back up at least ten feet (3m). Hesitate to demonstrate completion of the pattern.

Rider may dismount and drop bridle to the designated judge.

## Reining Pattern #9.

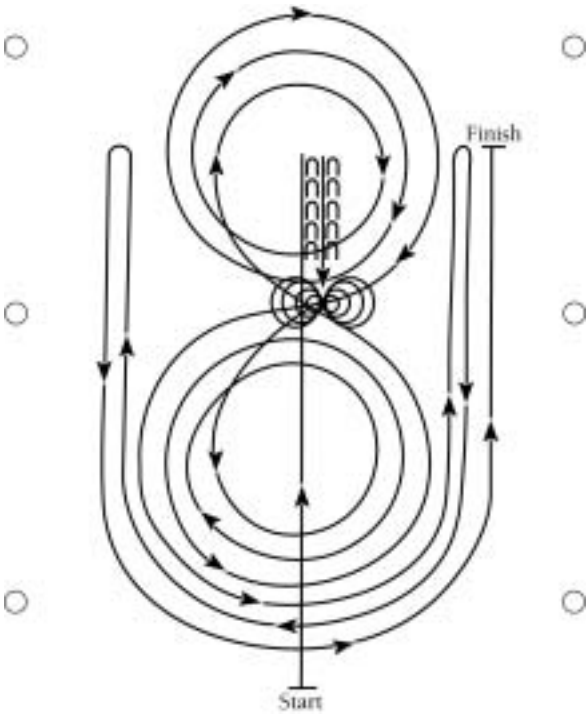

1. Run past the center marker and do a sliding stop. Back up to the center of the arena or at least ten feet (3m). Hesitate.
  2. Complete four spins to the right.
  3. Complete four and one-quarter spins to the left so that horse is facing the left wall or fence. Hesitate.
  4. Beginning on the left lead, complete three circles to the left: the first circle small and slow; the next two circles large and fast. Change leads at the center of the arena.
  5. Complete three circles to the right: the first circle small and slow; the next two circles large and fast. Change leads at the center of the arena.
  6. Begin a large fast circle to the left but do not close this circle. Run up the right side of the arena past the center marker and do a right rollback at least twenty feet (6.09m) from the wall or fence – no hesitation.
  7. Continue back around the previous circle but do not close this circle. Run up the left side of the arena past the center marker and do a left rollback at least twenty feet (6.09m) from the wall or fence – no hesitation.
  8. Continue back around previous circle but do not close this circle. Run up right side of the arena past the center marker and do a sliding stop at least twenty feet (6.09m) from the wall or fence. Hesitate to demonstrate completion of the pattern.
- Rider may dismount and drop bridle to the designated judge.

## Reining Pattern #10

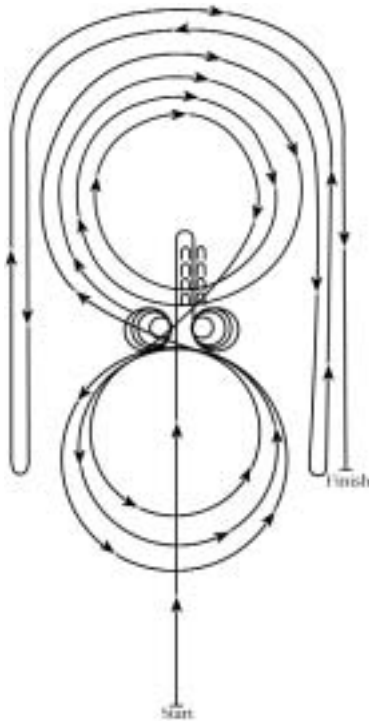

1. Run past the center marker and do a sliding stop. Back up to the center of the arena or at least ten feet (3m). Hesitate.
  2. Complete four spins to the right.
  3. Complete four and one-quarter spins to the left so that the horse is facing the left wall or fence. Hesitate.
  4. Beginning on the right lead, complete three circles to the right: the first two circles large and fast, the third circle small and slow. Change leads at the center of the arena.
  5. Complete three circles to the left: the first circle small and slow, the next two circles large and fast. Change leads at the center of the arena.
  6. Begin a large fast circle to the right but do not close this circle. Run down the right side of the arena past the center marker and do a left rollback at least twenty feet (6.09m) from the wall or fence – no hesitation.
  7. Continue back around the previous circle but do not close this circle. Run down the left side of the arena past the center and do a right rollback at least twenty feet (6.09m) from the wall or fence – no hesitation.
  8. Continue back around previous circle but do not close this circle. Run down the right side of the arena past the center marker and do a sliding stop at least twenty feet (6.09m) from the wall or fence. Hesitate to demonstrate completion of pattern.
- Rider may dismount and drop bridle to the designated judge.

## SC-265. WORKING COWHORSE

- A. WESTERN ATTIRE AND TACK. See Rule SC-235. and SC-240. Exception: Leg wraps and/or boots optional at rider's discretion. *See page 298 for legend for the following patterns (diagrams).*
- B. Both the cow work portion of this event and the reined work portion are mandatory. Scoring emphasis on the cow work portion shall be based on the horse maintaining control of the cow at all times, exhibiting superior cow sense and natural cow working ability without excessive reining or spurring. Failure of an exhibitor to attempt to complete the cow work portion of the class, as well as the reined work, will result in the exhibitor not being considered an entry in the class. A horse which attempts to complete the cow work but *has not been disqualified* will be scored accordingly at the judges discretion. A horse going off pattern in the reined work will receive a score of zero. A horse which attempts both the reined work and the cow work portion may be placed even if disqualified in one portion of the class. (Example: If a horse is disqualified and receives a 0 score for the reined work, but scores a 70 for the cow work, its total score would be a 70 and the horse would be eligible for placing.)
- C. The approved pattern will be used and each contestant will cause his horse to travel at the gait indicated for each part of the pattern. When judging reined work, the judge should refer to the reining portion of the handbook for guidelines.
- D. In approved working cowhorse classes, any of the *eight* approved APHA working cowhorse patterns may be used. One of the *eight* is to be selected by the judge of the class and used by all contestants in the class.
- E. For an ideal cow work, each contestant, upon receiving a cow in the arena, shall hold the cow on the prescribed end of the arena for sufficient time to demonstrate the ability of the horse to contain the cow on that end. After a reasonable amount of time, the contestant shall take the cow down the fence, making at least one turn each way on the fence. The contestant shall then take the cow to an open part of the arena and circle it at least once in each direction.
- F. The judge should take into consideration the size of the arena, condition of ground and the disposition and degree of difficulty exhibited by the cattle worked.
- G. At the discretion of the judge, cow work may be done immediately following each individual's pattern work or immediately after completion of pattern work by all horses being exhibited.
- H. *Horses should keep working until judge blows whistle. If exhibitor quits working before the judge blows the whistle, a score of 0 will be given.*
- I. The contestant's horse shall be penalized for general bad manners such as:
1. *One point penalties:*
    - a. *Loss of working advantage.*
    - b. *For each length horse runs past cow. A length by is 1 horse length of daylight between the cow's head and*

*the top of the horse's tail.*

- c. *Using the corner or the end of the arena to turn the cow. (In an oval arena, when the cow's head breaks the plane of the end marker.)*
- d. *Slipping a rein.*
- e. *Changing sides of arena to turn cow. (1 point each time.)*
- f. *Turning cow before passing middle marker on first turn.*
2. *Two point penalties:*
  - a. *Going around the corner of the arena before turning the cow. (When the cows head breaks the plane of the 2 point penalty marker.)*
3. *Three point penalties:*
  - a. *Knocking down the cow without having a working advantage.*
  - b. *Biting or striking the cow.*
  - c. *Hanging up on the fence (refusing to turn).*
  - d. *Exhausting or overworking the cow before circling.*
4. *Five Point Penalties:*
  - a. *Not getting one turn each way (5 points each way).*
  - b. *Spurring or hitting in front of cinch.*
5. *Zero (0) score:*
  - a. *Turn tail.*
  - b. *Using 2 hands on the reins in a bridle or two-rein class.*
  - c. *Fingers between the reins in a bridle class, except the two-rein class.*
  - d. *Balking.*
  - e. *Out of control or running over cow (Any horse that is out of control while working the cow, thus endangering the rider, i.e. crossing the path of the cow, shall be called off the cow.)*
  - f. *Bloody mouth.*
  - g. *Illegal equipment.*
  - h. *Leaving the work area before the pattern or work is complete*
  - i. *Fall of horse or rider*
  - j. *Schooling of the horse between the rein and cow work when the cow work immediately follows rein work.*

*NOTE: A judge may blow his/her whistle at anytime to terminate the work. A score of zero will be given if the work is not complete at that time.*

- J. *If time and number of cattle permit, the judge may, at his discretion, award new cattle, to enable the contestant to show his horse's ability on the cow, based on the following criteria:*
  1. *The cow won't or can't run.*
  2. *The cow won't leave the end of the arena.*
  3. *The cow is blind or won't yield to the horse.*
  4. *The cow leaves the arena. When a cow leaves the working area, it is automatic that the contestant will receive a new cow and scoring will begin again with the new cow.*
- K. *Scoring will be on the basis of 0 to 100, with 70 denoting an average performance. The same basis of scoring shall apply to both the reined work and cow work. In the event of a tie, the entry with the highest cow work will be declared the winner.*
- L. *The following characteristics of the horse or rider are consid-*

ered faults:

1. Exaggerated opening of mouth.
2. Hard or heavy mouth.
3. Nervous throwing of head.
4. Lugging on bridle.
5. Halting or hesitation while being shown, particularly when being run out, indicating anticipation of being set up.
6. Losing a cow or being unable to finish a pattern because of a bad cow, the contestant should be penalized at the judge's discretion.
7. Touching the horse or saddle with the free hand except during the cow work portion of the class, where the rider may hold onto the horn.

M. The characteristics of a good working cow horse are:

1. Good manners.
2. Shifty, smooth and having its feet under it at all times; when stopping, hind feet should be well under it.
3. A soft mouth and should respond to a light rein, especially when turning.
4. Head should be maintained in its natural position.
5. Work at reasonable speed and still be under control of the rider.
6. *The greater the difficulty of the run, the more credit should be given. The most controlled cow work with the highest degree of difficulty should be marked the highest.*

N. A show may have up to three approved working cow horse classes.

1. If three working cow horse classes are held at a show they shall be the following:
  - a. Senior working cow horse shown with bit.
  - b. Junior working cow horse shown with bit.
  - c. Hackamore/snaffle bit working cow horse (five-year-old and younger, shown with a hackamore or snaffle bit).
    1. No horse may be entered in both junior bit and hackamore/snaffle bit working cow horse classes at the same show.
2. If two working cow horse classes are to be held at a show, they shall be the following:
  - a. Senior working cow horse shown with bit.
  - b. Junior working cow horse shown with either a bit, hackamore or snaffle bit at the discretion of the exhibitor.
3. If only one working cow horse class is to be held at a show, it shall be the following:
  - a. Working cow horse - all ages (horses six-years-old and older must be shown in bit; horses five-years-old and younger may be shown in either bit, hackamore or snaffle bit at the discretion of the exhibitor).

O. The judge may request additional work at his/her option.

P. *Markers are mandatory for all patterns. Markers will be placed on the wall or fence of both sides of the arena to the approval of the judges with the following as a guideline:*

1. *At the center of the arena.*

2. The 1 point penalty marker for cow work shall be placed at each corner of the arena.
3. The 2 point penalty marker for cow work shall be placed approximately 16 feet past the 1 point penalty marker.
4. End markers for rein work shall be placed at the judge's discretion.

#### WORKING COWHORSE PATTERN #1

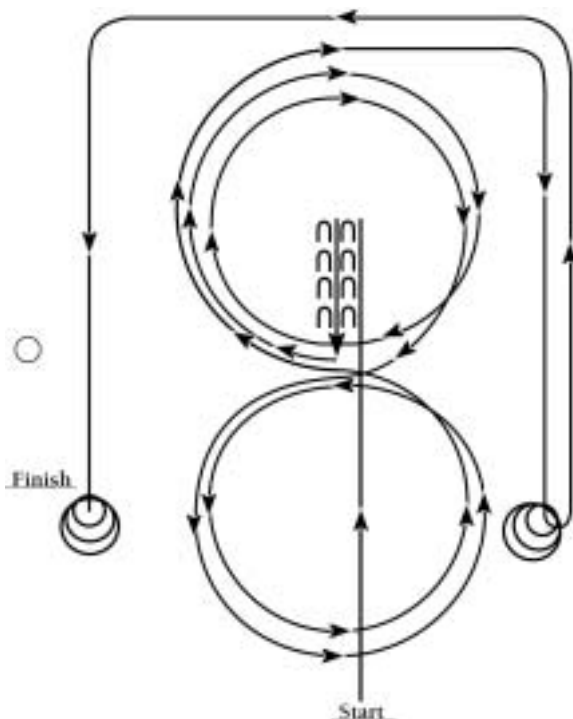

1. Start at end of arena. Run down middle past center marker to a sliding stop.
2. Back up 10 to 15 feet to center. 1/4 turn left.
3. Pickup right lead, big fast circle, small slow circle.
4. Change leads to left, big fast circle, small slow circle.
5. Change leads to right, do not close this circle.
6. Run around end of arena and down the side (approximately 20 feet from fence) past center marker and come to a sliding stop.
7. Complete 3 1/2 spins to the right.
8. Continue back down side and end of arena to other side (approximately 20 feet from fence) go past center marker and come to a sliding stop.
9. Complete 3 1/2 spins to the left.
10. Hesitate to complete pattern.

WORKING COWHORSE PATTERN #2

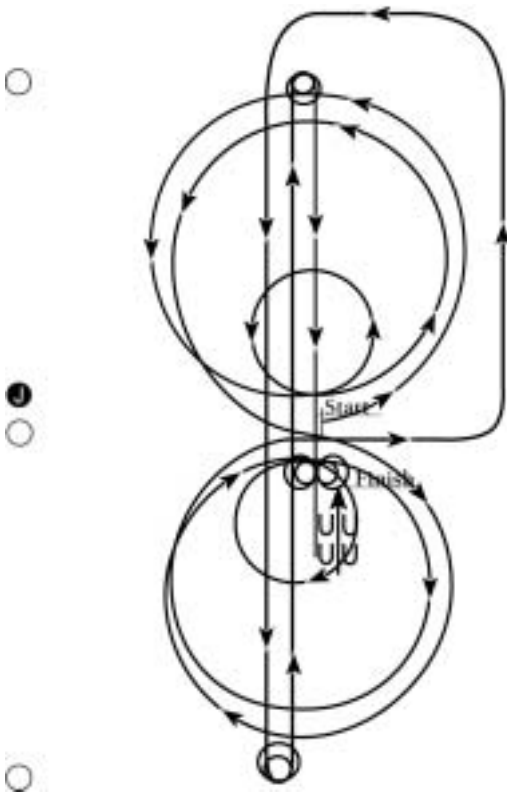

1. Proceed to center of arena, stop. Pick up left lead, complete 3 circles to the left. The first one large and fast, the second small and slow, the third large and fast.
2. Change leads at center of arena.
3. Complete 3 circles to the right. The first one large and fast, the second small and slow, the third large and fast.
4. Change leads at center of arena.
5. Do not stop, continue on to run downs.
6. Run to far end past the marker to a sliding stop. Hesitate.
7. Complete 2 1/2 spins to the left. Hesitate.
8. Run to far end past the marker to a sliding stop. Hesitate.
9. Complete 2 1/2 spins to the right. Hesitate.
10. Run past center marker to a sliding stop. Hesitate.
11. Back 10 to 15 feet in a straight line. Hesitate.
12. Make 2 full spins each way, either way first. Hesitate between spins.
13. Hesitate to complete pattern.

### WORKING COWHORSE PATTERN #3

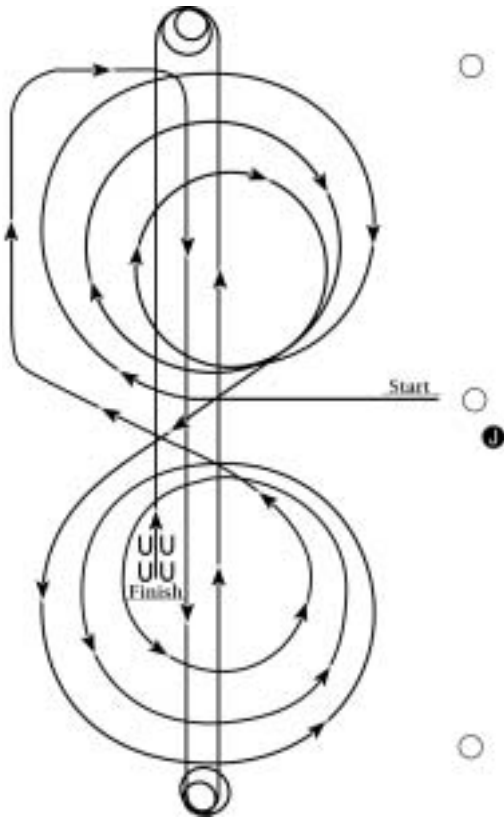

1. Proceed to center of arena.
2. Begin on right lead complete 3 circles to right, 2 big fast circles followed by 1 small slow circle, change to left lead.
3. Complete 3 circles to left, first 2 big, fast circles followed by 1 small slow circle. Change to right lead.
4. Continue loping around end of arena without breaking gait.
5. Run up center of arena to far end past the end marker and come to a sliding stop.
6. Complete 2 1/2 spins to the right.
7. Run up center of arena past the end marker, come to a sliding stop.
8. Complete 2 1/2 spins to the left.
9. Run back to middle of the arena past the center marker and come to a sliding stop.
10. Back 10 to 15 feet in a straight line.
11. Hesitate to complete pattern.

## WORKING COWHORSE PATTERN #4

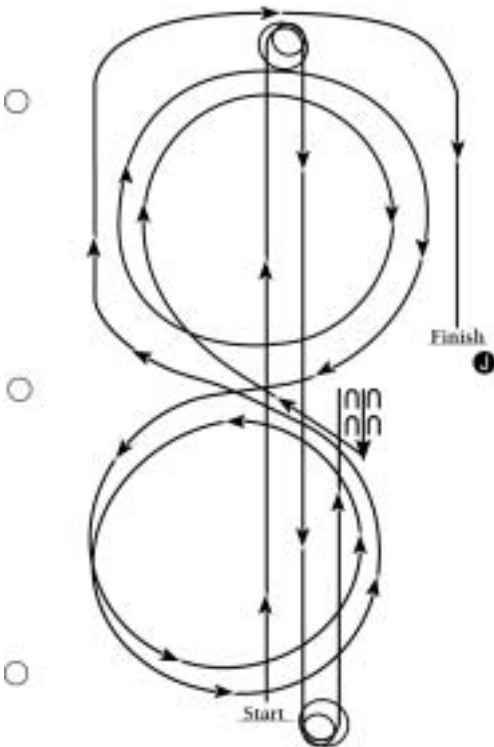

1. Start at end of arena.
2. Run up center of arena past the end marker and come to a sliding stop. Complete 2 1/2 spins to the left.
3. Run to other end of arena past the end marker and stop. Complete 2 1/2 spins to the right.
4. Run past the center marker and stop.
5. Back 10 to 15 feet in a straight line.
6. Complete 1/4 turn to the left, hesitate. Begin on right lead. Circle to the right.
7. Complete one small, slow circle and one large, fast circle. Change leads to the left.
8. Complete one small, slow circle and one large, fast circle, Change leads to the right.
9. Run around end of arena to the other side, past center marker, at least 20 feet from fence and come to sliding stop.
10. Hesitate to complete pattern.

## WORKING COWHORSE PATTERN #5

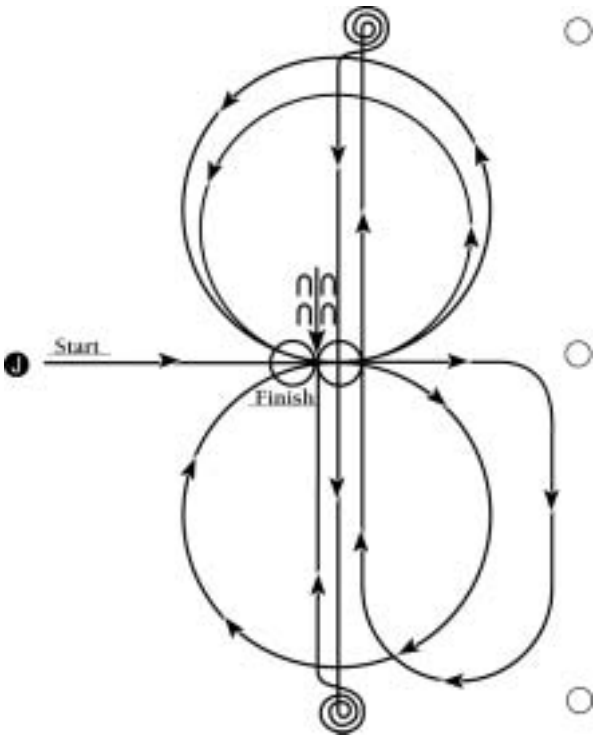

1. Proceed to center of arena, facing right wall or fence. Take a right lead and complete a circle to the right, away from the judge.
2. At the center of arena, change leads and do 2 circles to the left, of approximately the same size.
3. At the center of arena, change leads.
4. Go to the end of the arena and without stopping or breaking gait, run down the center of the arena past end marker.
5. Do a square sliding stop, hesitate.
6. Do 2 1/2 spins to the right.
7. Run full length of arena past end marker and do a square sliding stop, hesitate.
8. Do 2 1/2 spins to the left.
9. Run past center marker of arena; do a square sliding stop.
10. Back to center of arena (minimum of 10-15 feet).
11. Do 360-spin right or left.
12. Do a 360-degree spin opposite direction taken in #11.
13. Hesitate to show completion of pattern.

## WORKING COWHORSE PATTERN #6

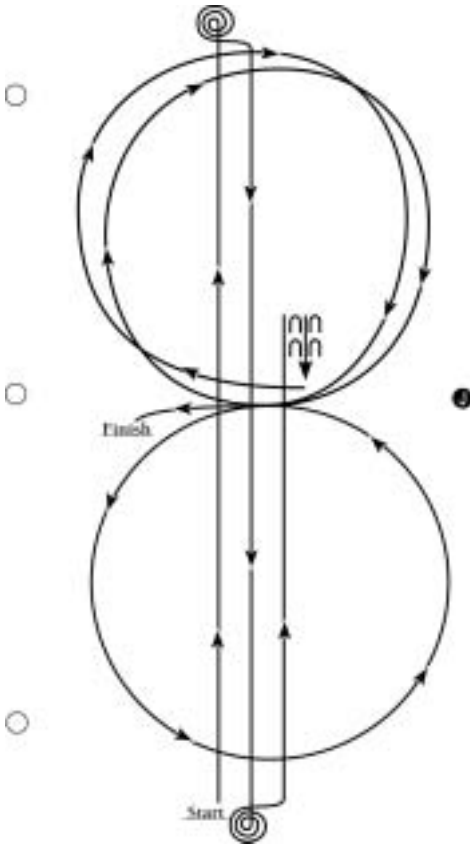

1. Start at end of arena.
2. Run down the middle of the arena, past the end marker and come to a sliding stop.
3. Complete 2 1/2 spins to the left.
4. Run to the other end of the arena, past the end marker and come to a sliding stop.
5. Complete 2 1/2 spins to the right.
6. Run back to the middle of the arena, past the center marker and stop.
7. Back 10 to 15 feet, hesitate.
8. Complete 1/4 turn to the left.
9. Start a circle to the right, change leads in the middle to the left lead. Complete circle and change to the right lead. Close circle and stop.
10. Hesitate to complete pattern.

WORKING COWHORSE PATTERN #7

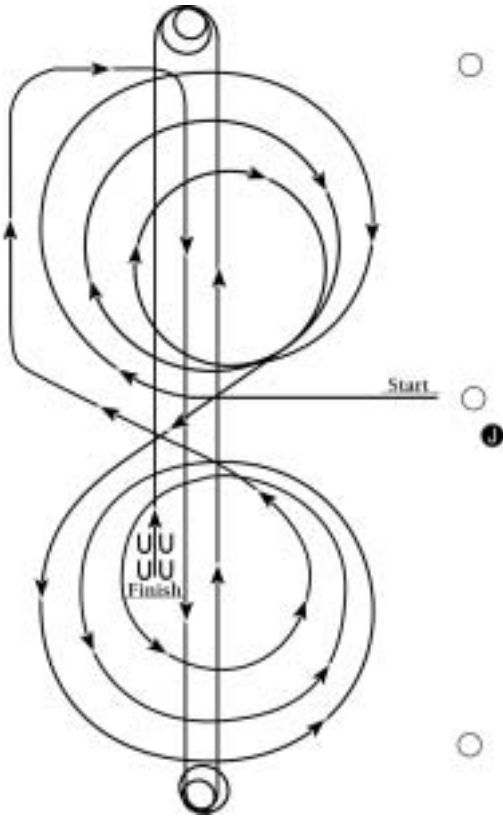

1. Proceed to center of arena. Pick up right lead and complete 3 circles, the first big, fast, the second small, slow, the third big, fast. Change leads to the left.
2. Complete 3 circles, the first big, fast, the second small, slow, the third, big, fast. Change leads to the right.
3. Continue loping around end of arena without breaking gait or changing leads.
4. Run down center of arena, past end marker and come to a sliding stop. Hesitate.
5. Complete 2 1/2 spins to the right.
6. Run down center of arena past end marker come to sliding stop. Hesitate.
7. Complete 2 1/2 spins to the left.
8. Run past center marker come to sliding stop.
9. Back up at least 10 feet.
10. Hesitate to complete pattern.

WORKING COWHORSE PATTERN #8

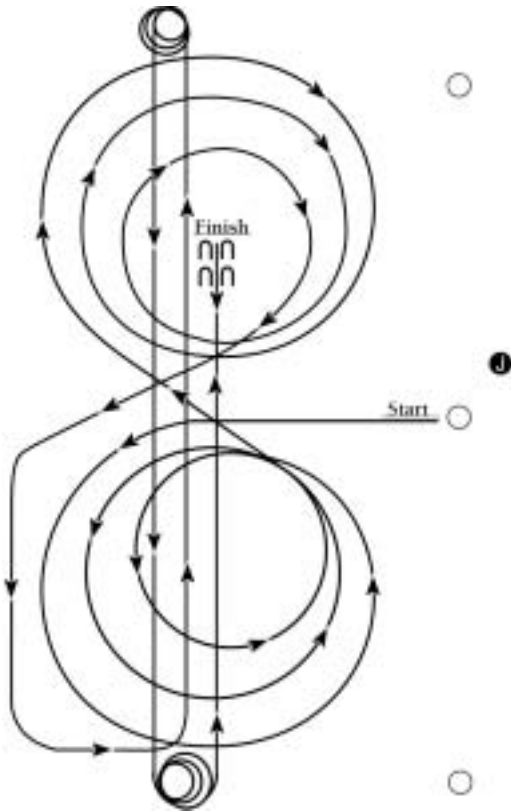

1. Proceed to center of arena and pick up left lead complete 3 circles; 2 large, fast circles, then 1 small slow circle. Change leads to the right.
2. Complete 3 circles to the right, 2 large, fast circles, then 1 small slow circle. Change leads to left.
3. Continue around end of arena without breaking gait or changing leads, run down center of arena past end marker come to square sliding stop.
4. Complete 3 1/2 spins to the left.
5. Run down center of arena past end marker come to square sliding stop.
6. Complete 3 1/2 spins to the right.
7. Run down center of arena past center marker come to square sliding stop.
8. Back up at least 10 feet.
9. Hesitate to complete pattern.

**SC-270. WESTERN ATTIRE AND TACK**  
**Roping, Speed Events and Team Penning**

- A. **WESTERN ATTIRE.** Exhibitors in all approved Paint Horse shows and contests are required to wear long sleeved shirts with collar, (band, tuxedo, stand-up, etc.), western hats and boots in western performance classes. See equipment and attire chart in back of rule book.
- B. **WESTERN TACK.** Western type equipment must be used. Horses shall be shown with a stock saddle; silver equipment will not count over a good working outfit. Bridle may be either a standard plain or silver headstall with a brow band, shaped ear or split ear. (See equipment and attire chart in back of rule book.)
1. **Bits.**
    - a. **Shanks.** Shanks may be fixed or loose.
    - b. **Mouthpieces.** In regards to mouthpieces, bars must be 5/16 inch (7.9mm) to 3/4 inch (1.9cm) in diameter, measured one inch from the cheek. Nothing, such as extensions or prongs, may protrude below the mouthpiece bar. The mouthpiece may be 2 or 3 pieces. If it is a three-piece, a connecting ring of 1 1/2 inches (3.81cm) or less in diameter or a connection flat bar of 5/16 inch (7.9mm) to 3/4 inch (1.9cm), measured top to bottom with maximum length of two inches. It must lie flat in horse's mouth.
  2. **Required Neck Rope (Tiedown Calf Roping Only).**

The rope must be run through a neck rope around the horse's neck, and may, at the discretion of the rider, be run through a "keeper".

    - a. **Optional Keeper** shall be defined as a small loop attached to the noseband, approximately 6 inches (15.24cm) in length and 1/4 inch (6.3mm) in diameter, consisting of rope. If a keeper is used, it must be attached to the noseband of the tiedown and cannot be attached to the bit or bridle.
  3. **Optional Equipment.**
    - a. Use of a hackamore, including mechanical hackamore with covered nosepiece or other type of western bridles and bits is the option of the contestant, provided it meets the specifications as listed in B.1. above. However, the judge may prohibit the use of bits or equipment he may consider too severe.
    - b. Tiedown made entirely of leather, nylon or rope.
    - c. Running martingales.
    - d. Leg wraps and/or boots.
    - e. The carrying of a rope or reata, other than the roping events.
    - f. Spurs.
    - g. Chaps or chinks.
  4. **Prohibited Equipment:**
    - a. Jerklines.
    - b. Tack collars.
    - c. Bicycle chains and mule bits.

- d. Any type of tiedown with bare metal in contact with the horse's head.

### SC-275. TEAM PENNING

- A. **WESTERN ATTIRE AND TACK.** See Rule SC-270. See equipment and attire chart in back of rule book.
- B. **DIVISIONS.** There will be three divisions only. Horse may be entered only once per division. All horses exhibited must meet the ownership and registration requirements for the division in which they are entered.
  1. **Open, All Ages.** In keeping with the rules of all other classes. Exhibitors may enter four horses, two Junior and two Senior, regardless of sex.
  2. **Amateur.** Exhibitors may enter two horses. All exhibitors in this division must possess current APHA Amateur cards.
  3. **Youth.** Exhibitors may enter two horses.
- C. **POINTS.** Points will be awarded based on the number of teams entered. Each horse on the team will be awarded points based on the APHA point System. See Rule SC-060.
- D. **PROCEDURE.** Within a 90 second time limit, a team of three APHA Registered Horses must cut out from the herd and pen three head of cattle with the assigned, same, identity number or colored neck band.
  1. **Numbers.** Numbers must be 6 inches (15.24cm) wide. The numbers must be applied to both sides of the animal, high upon its side, with the top near the midline of the animal's back between the shoulder and the hip.
  2. **Drawing For Order.** The numbers or colors and working order will be drawn for by the judge and show management before the start of the contest.
  3. **Flagmen/Timers.** There shall be two flagmen, one at the line must be an APHA judge, and one at the pen placed in a position not to interfere with the penning of the cattle and at least two timers.
  4. **Starting and Foul Line.** The starting and foul line must be designated by a marker located on the arena fence easily viewed by the line judge and the exhibitors. Show management reserves the right to adjust the starting and foul line to facilitate the competition.
  5. **Warning.** A warning must be given to the team working the cattle 30 seconds prior to a final time being called.
  6. **No Show.** If for any reason a team does not show after the order of go has been drawn, their cattle number will be drawn in the order the team would have run and the drawn number or color band will not be used in that set of teams. This will avoid changing the order of go for the other contestants.
  7. **Fall of Horse/Rider.** Fall of horse and/or rider shall not eliminate the entry.
  8. The fastest time wins.
- E. **TIES.** In the event of a tie affecting the placings, each team will be allowed to pen one numbered or color banded animal. Fastest time breaks the tie.
- F. **TIME BEGINS.**

1. All cattle will be bunched on the cattle side of the starting line before the time begins.
2. The time flagman will raise the flag to signal when arena is ready.
3. Contestants will be given their cattle penning number or color of neck band when the line flagman drops his flag as the nose of the first horse crosses the starting line. Riders are committed once they enter the arena.

#### G. **CALLING FOR TIME.**

1. To call for time, one rider must stand in the gate and raise a hand for the flag. Flag will drop when the nose of the first horse enters the gate and rider calls for time. All undesignated cattle must be on the cattle side of the starting line when the team calls for the time or the team will be automatically disqualified.
2. A team may call for time with only one or two assigned cattle penned; however, teams penning three head of cattle place higher than two, and two higher than one, regardless of time.
3. A team calling for time with any wrong numbered or colored neck banded cattle in a pen must be given **no time**.

#### H. **MULTIPLE GO ROUNDS.**

1. In a multiple go-round contest, in the event that teams pen their cattle in only one go-round, the fastest time wins, regardless of which go-round.
2. Also, in multiple go-round contests, teams that pen in each go-round will beat teams that fail to pen in a go-round, regardless of the number of cattle penned or time. **EXAMPLE:** Times in three go-rounds beat times in two go-rounds, times in two go-rounds beat time in one go-round, time in one go-round beats no time.

#### I. **CATTLE.**

1. A minimum of 15 head total and a maximum of 30 head for each go-round should be used.
2. As each new team begins a run, there must be 3 head of cattle per team in the arena.
3. There must always be the same number of cattle in each of the herds used in a go-round.
4. If cattle are to be re-used and additional fresh cattle are needed, the cattle must be mixed with fresh cattle and renumbered or color banded. Every attempt must be made to ensure each team work the same number of used and fresh cattle.
5. If more than four head of cattle cross the starting line **at any one time**, that team will be judged **no time**.

#### J. **RERUNS.**

1. In the event a warning of 30 seconds is not given prior to final time, a rerun may be given at the request of the team. If the team requests a rerun, the cattle will be settled and a rerun will be given immediately using the same number with a 60-second penalty.
2. In the event that more or less than three identical numbers or colored neck bands are discovered within a herd, the team with more or less than three identical numbers or col-

ored neck bands must have a rerun at the end of the total go-round. See Times. L.1. below.

3. If it is discovered there are more or less than the proper number of animals within a herd, only those teams affected with too many or too few identical numbered or colored neck banded cattle must be given a rerun.
4. Cattle may be used more than once; however, in the event a team is unintentionally given a number or colored neck band that has already been used within the herd, a rerun must be given immediately, using the correct number or colored neck band within that same herd. Should the error be discovered after the herd has been removed from the arena, then the rerun will be given at the end of the total go-round using the same herd.
5. If an animal leaves the arena, either over or through the fence, the team can either be disqualified for unnecessary roughness, or given a rerun, depending on the judge's decision. If a rerun is given, it must be given at the end of the total go-round. If no fresh cattle are available for reruns, the cattle to be used will be determined by the show management and the judge.
6. If more than one rerun is given in any go-round, they will be taken in the order of occurrence.

**K. TEAM RESPONSIBILITY TO CATTLE.** Once committed to the cattle, the team is completely responsible for their animals. It is the team's responsibility before working cattle to pull up and call for a judge's decision if, in their opinion, there is an injured or unusable animal in their numbered or colored cattle.

**L. TIMES IN MISNUMBERED HERDS.**

1. Times for all other teams not having more or less than three identical numbers or colored neck bands within a mis-numbered herd will remain the same.

**M. DISQUALIFICATIONS.**

1. Any delay in crossing starting line after line flagman drops his flag.
2. All un-designated cattle must be on the cattle side of the starting line when the team calls for the time. (Automatic disqualification.)
3. Contact with cattle by hands, hats, ropes, bats, romal or any other equipment.
4. A team exhibiting any unnecessary roughness. No hazing or popping romal or reins on chaps will be allowed.
5. Any attempt by a dismounted rider to work cattle.
6. If an animal leaves the arena, either over or through the fence, the team can either be disqualified for unnecessary roughness or given a rerun, **judge's decision.**
7. A team will be disqualified by the judge for any action he feels to be unnecessary roughness to the cattle or horses, or un-sportsmanlike conduct.

## N. COURSE DESIGN FOR TEAM PENNING.

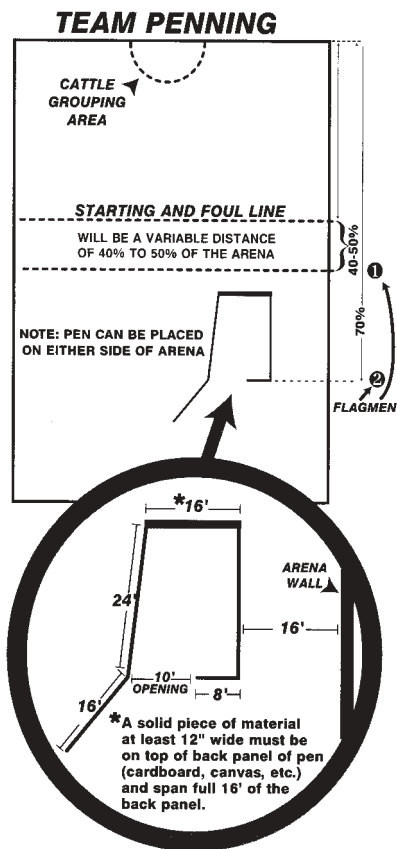

### SC-280. CALF ROPING

A. **WESTERN ATTIRE AND TACK.** See Rule SC-270 and equipment and attire chart in back of rule book.

B. **GENERAL RULES.**

1. **Scoring** will be done on the basis of 0-100 with 70 denoting an average performance.
2. **Performance.** Only the performance of the horse is to be judged. Time is not a factor to be considered.
3. **Barrier.** Horse must start from behind barrier. The horse will be judged on manners entering the box, behind the barrier, scoring speed to calf, rating calf, the stop, working the rope and his manners while roper is returning to horse after tie has been made.
4. **Breaking the Barrier.** Breaking the barrier is a fault not a disqualification, and should be judged accordingly.
5. **Exhibitor Fouled.** If, in the opinion of the line judge, the exhibitor is fouled by any moving part of the chute, barrier, etc., ropers shall get their calf back providing exhibitor declares himself by pulling up immediately.

6. **Rerun.** At the judge's discretion, a re-run may be given if the animal being roped leaves the arena or in the event of a malfunction of the chute or barrier.
7. **Disqualification.** The exhibitor shall not attempt to rope the animal until the barrier flag has been dropped. Any attempt by an exhibitor to rope the animal without leaving the barrier (box) shall be considered a disqualification.
8. **Loops.** A maximum of one minute or two loops, whichever comes first, will be allowed. If both loops are missed, contestant will retire with no score.
9. **If More Than One Loop is Thrown.** If more than one (1) loop is thrown, the rider must recoil the rope and build the additional loop. To encourage safety, use of a second rope will not be allowed.
10. **Catch.** Any catch that holds is legal but rope must remain on calf until tie is completed and roper has remounted. Calf must stay tied with legs crossed until roper remounts and rides forward to put slack in the rope. Failure of the calf to stay tied until the roper has remounted and ridden forward to loosen rope shall disqualify the entry. Once the rider has ridden forward one step and loosened the rope the run is complete.
11. **Touch or Dismount.** In calf roping classes, only roper may touch the calf while the horse is being judged. Roper may dismount from either side and leg or flank the calf.
12. **If Calf is Jerked Down.** If calf is jerked down by horse it must be allowed to regain its feet and roper must throw calf by hand, cross any three feet and tie with not less than one complete wrap and a half-hitch.
  - a. If calf is jerked down so that the calf is upside down with all four legs in the air at the same time, this will be cause for disqualification.
13. **Dragging the Calf.** Dragging the calf more than 10 feet will result in disqualification.
14. **Inducing Horse to Perform.** Any unnecessary whipping, jerking reins, talking or any noise-making, slapping, jerking rope or any unnecessary action to induce horse to perform better, will be considered a fault and scored accordingly.

## SC-285. TEAM ROPING/STEER STOPPING

- A. **WESTERN ATTIRE AND TACK.** See SC-270 and equipment and attire chart in back of rule book.
- B. **TWO DIVISIONS OF STEER ROPING.** Two different divisions of steer roping are acceptable as approved events. Show may have either or both.
  1. Team Roping.
  2. Steer Stopping.
- C. **GENERAL RULES.**
  1. **May Show Both Heading or Heeling.** A horse shall be allowed to show in Heading or Heeling, or both.
  2. **Declare in Which Event Competing.** It must be declared before the horse enters the arena, however, in which event the horse is competing during the run.

3. **Scored Individually.** The heading horse and the heeling horse are to be entered and scored individually, not as a team.
4. **Horse Not Being Judged.** A heading or heeling horse assisting the horse being judged need not be a regular registered APHA horse.
5. **Manners.** The manners of the horse being judged will be judged at all times.
6. **Dropping Rope.** If a header or heeler drops his rope, the contestant being judged will receive **no time**.
7. **Run Complete.** The run is complete when both ropes are tight and horses are in a facing position. Time is not a factor.
8. **The Rider Not Being Judged.**
  - a. **Loops.** May use as many loops as necessary to make the catch within a *one* minute time limit.
  - b. **Legal Catch.** Any catch by the heeler not being judged must be a legal catch defined as a catch which holds from behind the steer's shoulders and back, around the flank, or on one or both heels, but not by the tail only.

#### D. JUDGING HEADING HORSE.

1. Only the heading horse shall be started and judged behind a barrier, on the rate of speed, ability of horse to rate, check, set and turn the steer into position for heeler and turn and face the steer until rope is tight.
2. Breaking the barrier is a fault, not a disqualification, and should be judged accordingly.
3. When heading horse is being judged, the roper may throw only two loops. If roper misses with both loops, they are to retire from the arena with no score.
4. **Catch.**
  - a. **Legal** catches in heading are both horns, half head and around the neck.
  - b. **Illegal** catches are any figure eight catch or front leg in the catch.
5. The rider must dally on the horse being judged.
6. The horse/rider not being judged may tie, dally or pull tight. See rule SC-285.C.6.

#### E. JUDGING HEELING HORSE.

1. The heeling horse shall be judged in the box on ease of manner in which he turns and prepares for heeler's position to throw loop, set and stop steer while holding rope tight in preparation for header's facing.
2. When heeling horse is being judged, a headloop must be placed on the steer's head or horns before the animal leaves the chute.
3. When heeling horse is being judged, the roper may throw only two loops. If roper misses with both loops, they are to retire from the arena with no score.
4. A legal catch is defined as a catch which holds from behind the steer's shoulders and back, around the flank, or on one or both heels, **but not by the tail only**.
5. The rider must dally on the horse being judged.
6. The horse/rider not being judged may tie, dally or pull

tight. See rule SC-285.C.6.

**F. STEER STOPPING.**

1. Horse to be judged on manners behind the barrier and at all times. The horse shall be judged on the rate of speed to steer, ability of horse to rate, check, stop straight and to stop and turn the steer to face horse.
2. There is a time limit of *one* minute or two loops, whichever comes first. If roper fails to catch, he will retire from the arena with no score.

**G. SCORING.** Team Roping and Steer Stopping Horses shall be scored on the basis of 0 to 100 with 70 denoting an average performance.

1. Any unnecessary whipping, jerking reins, talking or any noisemaking, slapping, jerking rope or any unnecessary action to induce the horse to perform better, will be considered a fault and scored accordingly.

### SC-286. CUTTING

APHA strongly recommends APHA cutting classes be held whenever possible.

- A. National Cutting Horse Association or Canadian Cutting Horse Association rules will be used for conducting and judging cutting. All riders in the arena shall comply with rules of dress, equipment and conduct and be limited to bona fide contestants or their helpers per NCHA rules.
- B. If a show holds both NCHA- and APHA-approved cutting classes, separate works must be held for each event. The scores earned in the NCHA cutting may not be used as scores for the APHA cutting at the same show.
- C. Rules for the National Cutting Horse Association are available from the National Cutting Horse Association, 4704 Highway 377 South, Fort Worth, Texas 76116.
- D. Rules for the Canadian Cutting Horse Association are available from the Canadian Cutting Horse Association, RR 1, Airdrie, Alberta, Canada T4B 2A3.
- E. If both NCHA- and APHA-approved cuttings are held at one show, points will be awarded only in the APHA-approved cutting classes.
- F. For NCHA-approved cutting, APHA points shall be awarded only on the basis of the signed records of the show or contest, forwarded to APHA by show management providing:
  1. Horses compete under their APHA registered name.
  2. The competition was held in conjunction with an all-age show approved by APHA, and
  3. No APHA-approved cuttings were held at that show.

### SC-290. BARREL RACING

- A. **WESTERN ATTIRE AND TACK.** See Rule SC-270 and equipment and attire chart in back of rule book.  
**Exception.** A safety helmet is permitted.
- B. **SETTING THE PATTERN FOR THE APHA BARREL RACING COURSE.**
  1. **Pattern Purpose.** The cloverleaf pattern is designed to test

the speed and maneuverability of the horse.

2. **Measure Course.** The course must be measured **exactly**. If the course is too large for the available space, then the pattern should be reduced 5 yards (4.57m) at a time until the pattern fits the arena.
3. **Ample Room.** Remember to set your course so that a horse may have ample room to turn and stop.
4. **Space Between Barrels.** Remember to leave adequate space between barrels and any obstacle. The distance from barrel number 3 to finish line need not be reduced by 5 yards (4.57m) at a time if there is sufficient room for the horse to stop.

#### C. INSTRUCTIONS FOR RUNNING THE COURSE.

1. **Signal from Starter.** At a signal from the starter or timer, such as the "go", the contestant will go to the barrel number 1 turning to the right of this barrel, complete a 360 degree turn, then on to barrel number 2, this time turning to the left with another 360 degree turn. At barrel number 3 the same passage to the left and 360 degree turn is accomplished.
2. **Sprint to Finish.** As soon as the turn is completed around barrel 3, the contestant sprints the horse to the finish line where the electric timer or timers stop their watches as soon as the horse's nose reaches the finish line.
3. **May Run to Left.** The barrel course may also be run to the left. For example: the contestant will start to barrel number 2, turning to left around this barrel, then to barrel number 1, turning to the right, then barrel number 3, turning again to the right, followed by the final sprint to the finish line.

#### D. TIME.

1. **Timed Event.** The barrel race contest is strictly a timed event.
2. **Running Start.** The contestant is allowed a running start. Timing shall begin as soon as the horse's nose reaches the starting line and will be stopped when the horse's nose passes over the finish line.
3. **Time Announced.** The score, time, of each entry will be announced immediately following the horse's run.
4. **Penalty.** *A five second penalty will be assessed:*
  - a. *For each barrel knocked over;*
  - b. *If the hat or helmet is not on the exhibitor's person for the entire time the exhibitor is in the arena barrel racing.*
5. **Time Calculation.** A clearly visible starting line shall be provided. An electric timer may be used. If electric timer is used there must be two backup stop watches. The average time of the watches must be recorded on each run in case the electric timer becomes inoperable during the contest. If the electric timer fails, a rerun will be given at the completion of the class or at the time the failure occurs. The choice will be that of the exhibitor. If the electric timer becomes inoperable during contest, all official times will be from the average of the hand times.

## E. DISQUALIFICATION.

1. **Hat or Safety Helmet.** Contestant must be wearing a western hat or safety helmet when they enter the arena or the exhibitor will be disqualified.
2. Failure to follow the course.
3. Any deviation from the pattern.

## F. TIES.

1. In event of a tie, the horse declared the winner in the runoff must run the pattern within two seconds of its original time or the runoff must be held again.
2. The tie may be broken in compliance with Rule SC-185.N.

## G. BARREL RACING PATTERN.

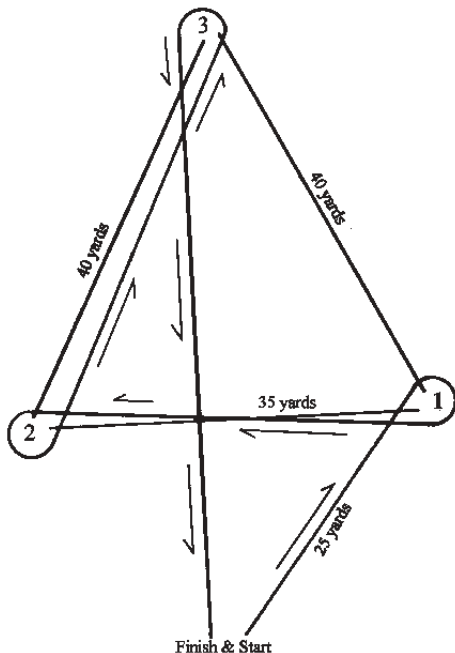

## SC-295. POLE BENDING

A. **WESTERN ATTIRE AND TACK.** See Rule SC-270 and equipment and attire chart in back of rule book.

**Exception.** Safety Helmet is optional.

## B. RUNNING THE PATTERN.

1. Each contestant will begin from a running start.
2. A clearly visible starting line should be provided.
3. The pole bending pattern is to be run around six poles. Each pole is to be twenty-one (21) feet (6.40m) apart and the first pole is to be twenty-one (21) feet (6.40m) from the starting line.
4. A horse may start either to the right or to the left of the first pole and then run the remainder of the pattern accordingly. See pattern.

## C. TIMED EVENT.

1. Pole bending is a timed event. An electric timer may be used. If electric timer is used, there must be two backup stop watches. The average time of the watches must be recorded on each run in case the electric timer becomes inoperable during the contest. If the electric timer fails, a rerun will be given at the completion of the class or at the time the failure occurs. The choice will be that of the exhibitor. If the electric timer becomes inoperable during the contest, all official times will be from the average of the hand times.
2. A five second penalty will be allotted for each pole knocked over and for each pole touched by the rider's hand.
3. *Penalty. A five-second penalty will be assessed if the hat or helmet is not on the exhibitor's person for the entire time the exhibitor is in the arena in pole bending.*
4. The time of each entry will be announced immediately following the horse's run.

#### D. DISQUALIFICATION.

1. Any deviation from the pattern.
2. Failure to follow the course, loss of course includes negotiating obstacles in any other than specified order, the wrong direction, stopping, circling, backing or reversing direction of movement to correct improper passing of an obstacle.

E. **TIES.** In the event of a tie, the horse declared the winner in the runoff must run the pattern within two seconds of its original time or the runoff must be held again. The tie may be broken in compliance with Rule SC-185.N.

#### F. POLE BENDING PATTERN.

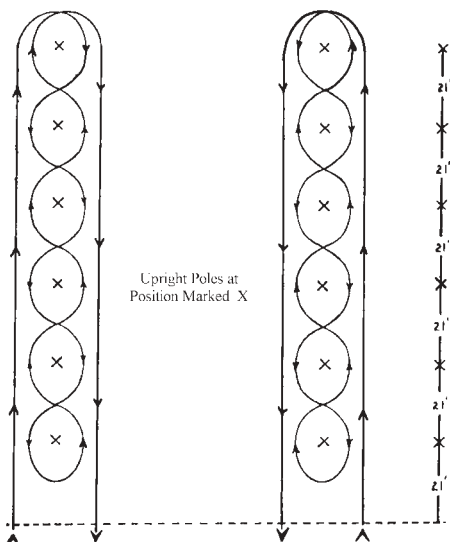

## SC-296. STAKE RACE

- A. WESTERN ATTIRE.** See Rule SC-270.A. Exception: Safety helmet is optional.
- B. WESTERN TACK.** See Rule SC-270.B.
- C. TIMED EVENT.** This is a timed event. For time calculation see Rule SC-290.D.5.
- 1. Penalty. A five second penalty will be assessed if the hat or helmet is not on the exhibitor's person for the entire time the exhibitor is in the arena in stakes race.*
- D. MARKERS.** The start and finish line is 20 feet (6.09m) wide and marked by two upright markers, 10 feet (3m) on each side of the center line and short enough so as to not interfere with the timer if one is used. Short pylons or cones are recommended. The first and second poles marking the center line are each 40 feet (12.19m) from the start and finish line, making them a total of 80 feet (24.38m) apart.
- E. START.** Start by crossing the start and finish line between the two upright pylons or cones, run a figure eight (8) around the upright poles marking the center line, and finish by again crossing the start and finish line between the pylons and cones and closing the eight (8).
- F. CLASS PROCEDURE.** At the first pole, the contestant may go left or right just so the figure eight (8) is run.
- G. NO TIME.** If the figure eight (8) is not completed, or if the upright pole is knocked down, there is NO TIME.
- H. STAKE RACE PATTERN.**

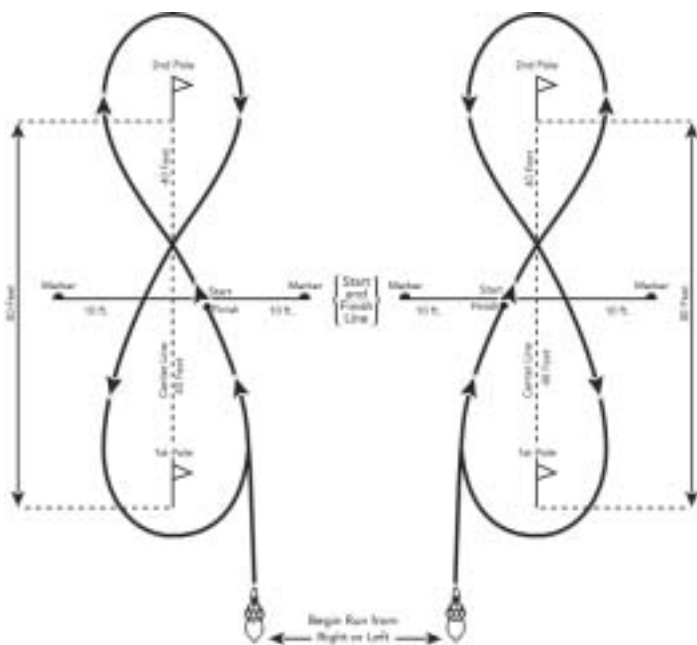

## SC-300. COW PONY RACE

- A. **WESTERN ATTIRE AND TACK.** See Rule SC-235. and SC-240, also see equipment and attire chart in back of rule book.

### **Exceptions.**

1. Shank bits with curb must be used.
2. No "D" bits shall be allowed.
3. Stock saddle must have horn.
4. Only two reins can be used.
5. Horses with racing plates shall not be allowed.
6. The interpretation of questionable equipment shall be left to the discretion of the official judge.

### **Optional.**

1. Leg wraps and/or boots optional at rider's discretion.
2. Safety helmets or hard hat.

- B. **PURPOSE.** This contest is a race to stimulate the common practice of cowboys who often settle arguments of who owned the fastest cowhorse by holding impromptu races on the range.

- C. **COMPETING INDIVIDUAL MINIMUM AGE.** Minimum age limit for individuals competing in the cow pony race shall be (16) years of age.

- D. **PROCEDURE.**

1. A walking start must be used and the starter's word shall be official.
2. The official judge of the show must select one or more assistants to help judge the race. The judges must be positioned at opposite sides of the finish line.
3. The distance of the race will be up to the discretion of the show committee. However, the distance of the race(s) must be listed on the show program.
4. Preliminary heats should be run where track conditions do not permit all horses to run at one time. The track size should allow at least six (6) feet (1.82m) per horse in each race.

- E. **DISQUALIFICATIONS.** The judge or any appointed assistant may disqualify any horse which he feels has interfered with another horse or rider.

- F. **TIES.** All ties must be run off.

- G. **POINTS.**

1. Points shall be awarded under the APHA point system. Times will not be recorded by APHA. If more than one heat is required, points will not be awarded in each heat, but in the finals only.
2. Points will be awarded on the basis of total number of competing entries in the race.

- H. **DRUGS.** Drug rule shall be the same as in other classes and events.

- I. **IF HELD AT AN APPROVED NON-PARI-MUTUAL TRACK.** If cow pony races are written for APHA approval at an approved non-pari-mutual track during an approved race meet or approved day of racing, the cow pony races will be the last Paint Horse races on the program.

## SC-325. BREEDING STOCK RULES

### A. BREEDING STOCK PROGRAM.

1. Effective January 1, 1980, horses registered in the Breeding Stock, Appendix Breeding Stock and Identification Registries are eligible to compete in Breeding Stock Classes only. See Rule RA-000.D., Exception: Effective January 1, 1987, Breeding Stock sire and dams may be entered in the following group halter classes; Produce of Dam and Get of Sire, provided the requirements of Rule SC-180.A. are met.
2. For any situation not covered by the breeding stock program rules and regulations, the rules and regulations of the APHA Show & Contest Open Division shall apply.

### B. APHA TITLES AND AWARDS.

1. **Fraudulent Advertising.** The registration certificate of any horse may be revoked permanently by the Association if the owner thereof fraudulently advertises, claims or holds forth that this certain horse is entitled to any title awarded by the APHA prior to the title being officially awarded by the APHA, or uses a title other than the official title of the award as specified by APHA rules.
2. **“Breeding Stock” must Precede Promotion of Titles/Awards.** All promotion of titles and awards won must be preceded with the words “Breeding Stock”. Example: Breeding Stock Superior Western Pleasure. The absence of such word may subject the owner to disciplinary action as covered under rule GR-070.
3. **Certificate to Record Owner.** A proper notation shall be made in the records of the APHA and a proper certificate shall be prepared and sent to the record owner of said horse.

### C. APHA BREEDING STOCK REGISTER OF MERIT.

1. Horses are advanced to the Breeding Stock Register of Merit when said horse has earned at least ten (10) points in the scale of points for contests in any one event as shown in SC-325.K.
2. A horse may receive this title for each separate event in which ten (10) points are earned.

### D. APHA BREEDING STOCK SUPERIOR EVENT HORSE.

1. Horses are awarded the title of “Breeding Stock Superior Event Horse” when said horse has earned fifty (50) or more points in the scale of points of contests in one APHA approved event as shown in Rule SC-325.K.
2. A horse may receive this title for each separate event in which (50) points are earned.

### E. APHA BREEDING STOCK HONOR ROLL.

1. Breeding Stock Honor Roll, see Rule SC-040.A.-F. for method of tabulation. Breeding Stock Exception Rule SC-040.F.

### F. APHA BREEDING STOCK CHAMPION.

1. The title of “APHA Breeding Stock Champion” may be awarded to any individual stallion, mare or gelding registered according to Rule SC-165.C. after it has won a total

of 40 or more points in competition in official shows or contests approved by the APHA, provided:

- a. The points have been won in five (5) or more shows or contests and under five (5) or more judges.
- b. That at least sixteen (16) points have been won in halter classes and of these sixteen (16), a minimum of ten (10) points must have been won in either A or B class shows. See Rule SC-055. and SC-060.A.
- c. That at least sixteen (16) of these points have been won in performance classes or contests and with a minimum of five (5) points each having been earned in at least two categories of performance events as set forth in Rule SC-325.K., *excluding Category VIII*. These five (5) points must be earned in at least two (2) categories and cannot be earned in a combination of categories.

2. This award is retroactive.

**G. APHA BREEDING STOCK TOP TEN AWARD.** *Halter and Performance. Year-end recognition will be given to the ten open breeding stock horses who earn the most points in open breeding stock halter and performance classes.*

1. *Shows Counted. Total points will be compiled on horses from January 1 through December 31. Total points from all shows will be tabulated.*
2. *Awards. An appropriate award will be mailed to the record owner of the first through tenth place horse.*

**H. APHA BREEDING STOCK ZONE TOP FIVE AWARD.**

1. *This award would recognize the top five horses in each of the zones. This award is based on total cumulative points earned within the respective zone the horse is owned. Exhibitors do not have to live in the zone. (See Rule SC-105.B.3.f-g. for states, provinces, and countries listed in the respective zone.) As long as horse/owner remain in the same zone, points will accumulate on horse (horse may be transferred to someone within the same zone).*
2. *Tiebreaker System:*
  - a. *Horse with greater number of performance points.*
  - b. *Most points earned in fewest shows.*
3. *Awards. An appropriate award will be mailed to the record owner of the first through fifth place horse.*

**I. CLASSIFICATION OF SHOWS.**

1. Entries in Breeding Stock classes will count toward classification of a show under Rule SC-055.
2. Results of the approved Breeding Stock classes will be published in the Paint Horse Journal with the results of the show.

**J. POINTS.**

1. Horses exhibited in Breeding Stock classes will earn points as described in Rule SC-060.
2. Points shall be earned only by qualifying horses 1-year-old or older.
3. Horses of point earning ages may be combined with horses of non-point earning age in Breeding Stock classes. Only horses one year of age and older will count in the number of horses per class for point tabulation but will

count towards number of entries in the show.

4. No Grand or Reserve Championship halter classes will be held for Breeding Stock horses. See Rule SC-175.F.-H. and SC-180.A.1.2.

K. **RECOGNIZED CLASSES.** The following are recognized classes for Breeding Stock and Identification Status horses. Rule SC-165.C. The classes may be offered at the option of show management in conjunction with APHA shows. Shows may offer any or all classes at their discretion.

1. **Halter.**

a. Mares.

1. Weanlings.
2. Yearlings.
3. Two-Year-Olds.
4. Three-Year-Olds.
5. Four-Year-Olds and Older.
6. Broodmares.

b. Stallions.

1. Weanlings.
2. Yearlings.
3. Two-Year-Olds.
4. Three-Year-Olds.
5. Four-Year-Olds and Older.

c. Geldings.

1. Weanlings.
2. Yearlings.
3. Two-Year-Olds.
4. Three-Year-Olds.
5. Four-Year-Olds and Older.

2. **Performance.** The following performance categories are approved for breeding stock horses.

a. Category I (no classes available in this category)

- b. Category II
- Barrel Racing
  - Pole Bending
  - Cow Pony Race
  - Stake Race
  - Team Penning

c. Category III

- Reining
- Western Riding
- Working Cow Horse
- Trail
- Utility Driving

d. Category IV

- Working Hunter
- Hunter Hack
- Jumping

e. Category V

- Cutting
- Calf Roping
- Team Roping Heading
- Team Roping Heeling
- Steer Stopping

f. Category VI

- Hunter Under Saddle
- Pleasure Driving
- Western Pleasure

g. Category VII

- Racing

- h. Category VIII Yearling Longe Line (this category eligible for ROM only)

**FOR RULES TO ANY OF THE ABOVE APPROVED BREEDING STOCK EVENTS, REFER TO THE CORRESPONDING OPEN EVENT IN THE SHOW & CONTEST SECTION OF THIS RULE BOOK.**

## JUDGES

### **JU-000. JUDGE RULES AND REGULATIONS**

The following Rules and Regulations shall become effective January 1 of the current year, and thereupon all Rules and Regulations and parts thereof-heretofore in force are hereby repealed.

#### **A. JUDGE APPROVAL REQUIREMENTS.**

1. **Membership.** The following rule in regard to judges is mandatory. A judge must be a current member in good standing of the APHA. Such membership is required in order to appear in the PAINT HORSE JOURNAL and is considered delinquent after January 1. Six months after that date, a judge's name will be removed from the list and reapplying would be necessary for possible reinstatement.
2. **Qualifications.** The qualifications sought among others are: equine expertise, personal character and interest in the Paint Horse breed. An individual's conduct as a member, exhibitor and judge and his ability must be exemplary, and is subject to continual committee review.
3. **Designation A Privilege.** Designation as an approved APHA judge is a privilege only, not a right. Subject to Executive Committee review, this privilege may be bestowed by the Judges Committee of the APHA. Subject only to Executive Committee review, the Committee may give the designation or revoke the same in accordance with the procedures set up by this Committee.
4. **Agree To Abide By Executive Committee Decision.** Any member or individual approved as an APHA judge agrees to abide by the decision of the Executive Committee, as the final determination of all rights to such status.
5. **Approved Status And Review.** A judge's approved status will remain valid and in effect, unless revoked, for a period of three (3) years. At the end of that period, the judge's approved status is subject to automatic review and disposition by the Judges Committee subject to Executive Committee approval. At that time, a judge's status may:
  - a. Be renewed as is for another three (3) year interval, or
  - b. Be provisional; renewed for a shorter period with or without restriction or,
  - c. Not be renewed.
6. **Attend Judges Seminar.** All APHA judges are required to attend an APHA approved judges seminar once every three years.

#### **B. SELECTION OF JUDGES.** Judges must be selected from the current approved list of the American Paint Horse Association effective January 1 of the current year.

1. **Request For Judges List.** Upon request, the office of the Executive Secretary of the APHA will furnish a list of qualified and approved judges to organizations or persons spon-

soring shows or contests.

**C. SHOW REQUIREMENTS AND RESTRICTIONS FOR JUDGES.**

1. Mileage Requirement Between Shows. No person may judge two (2) shows within two hundred (200) miles (321.869km) of each other within thirty (30) days.
2. Number Of Shows.
  - a. Restricted Number. No person may judge more than two (2) approved shows, excluding Special APHA Paint Events, county fair shows, and district fair shows, or single classes in one (1) state of the United States, one province of Canada or one (1) country other than the U.S. and Canada during one (1) calendar year.
  - b. Required Number. An approved APHA judge must judge at least one APHA horse show each year in order to maintain their APHA judges status excluding Special APHA Paint Events.
3. Judging At An APHA Sponsored Show. Judges contracted to officiate at show(s) sponsored by the APHA shall not judge any other APHA-approved show within thirty (30) days prior to the APHA-sponsored show.
4. Judging Consecutive Shows. No judge shall officiate two (2) consecutive times at the same show *or set of shows* or contest.
5. Judges Involved In Show Management. Any APHA approved judge involved in the management of a show cannot officiate as a judge at that show.

**D. JUDGING COMMITMENT.** After acceptance of a judging commitment, a judge shall endeavor, with all reasonable effort, to *fulfill the commitment*.

1. Inability to *fulfill the commitment*. A Judge shall timely communicate to show managers any inability to *fulfill* commitment, so as to allow the show manager maximum time in which to seek a suitable replacement. Additionally, the judge shall immediately file with the Association written explanation of such inability to meet his commitment, specifying the date and manner in which he communicated to the show and with whom he communicated.
2. Arriving At Prescribed Time. A judge, upon arrival in a city in which he is to officiate should contact an official of the show or contest and advise him of his presence and location. A judge not showing up at the prescribed time without reasonable explanation may be suspended from judging for one year.
3. Judge Unable To Complete Judging Assignment At Show. Any judge who is unable to complete his judging assignment at the show after arriving on the show grounds shall submit a written statement to the APHA. The show management shall select a suitable replacement and notify the APHA in writing.

**E. APPROPRIATE ATTIRE.** Western attire, including long sleeves, pants and western hats and boots, is mandatory apparel for an individual to wear while judging an approved show or event. Exception: Where show circumstances are best served

by alternative attire.

F. **CONDUCT.** A person who is an approved APHA judge shall, at all times, whether serving as a judge, spectator, or exhibitor, remember that he/she is a representative of the APHA and should project and conduct himself/herself in a professional manner, and be a model of good sportsmanship. (See JU-000.A.2.)

1. **Attendance At Show Prior To Commitment.** A judge shall not attend a show, or exhibitor's party, or any other activity in the general location that is connected with a show on the day previous to the show at which he is officiating. Exception: Multi-breed shows, stock shows or fairs.
2. **Arrival On Grounds.** A judge shall not appear on the show or contest grounds prior to fifteen (15) minutes before judging.
3. **Fraternization/Perception.** A judge shall not visit in the horse barns, nor with owners, exhibitors, or other judges, nor inspect or discuss any horse entered in the show or contest before judging, nor shall he review the judging program until after the judging has been completed.
4. **Prohibited Use.** APHA judges are prohibited from using tobacco and/or alcohol products, cellular phones, beepers, or electronic communication devices for personal use in the arena during an approved show.
5. **Conflict of Interest.** Association judges are to be sensitive to any conflict of interest between the Association's objectives and their own personal business or pecuniary interests.
  - a. **Actions Of Immediate Family Members.** Neither the judge nor members of his immediate family shall exhibit or act as agents, representatives in any capacity or handlers of a horse in any approved single judge or multi-judge show, (or back-to-back show or contest preceding or following the show) at which he is officiating. (For immediate family, see Rule SC-160.N.)
  - b. **Horses In Conflict.** No horse may be shown to a judge if that judge or members of his immediate family have owned, trained, or acted as agent, conditioned or exhibited the horse, in any class except as secondary handler in Grand or Reserve, within the previous six months.
  - c. **Horses Owned Or Exhibited.** A judge shall not judge a horse which is owned or exhibited by anyone from whom he or members of his immediate family have paid or received a salary, commission, or any type of remuneration or consideration, directly or indirectly, within six months of the date of the show in question. **EXCEPTION:** Breeding fees, mare care, vet expenses, shipping fees, or any other fees related to breeding.
  - d. **Multi-Judged Shows.** In a multi-judged show, if a judge is confronted with an entry that poses a conflict of interest, the judge shall not judge that entry but that entry will be counted toward the total number of horses in the class. The judge will mark his card and the number of entries and will make a notation on his card

that the entry is a conflict. A judge and/or person (s) involved may be suspended for infraction of this rule.

1. **Horses Owned By The Judge.** No horses owned by the judge or members of his immediate family shall exhibit in any approved single judge or multi-judge show, (or back to back show or contest preceding or following the show) at which he is officiating (for immediate family, see Rule SC-160.N.)

#### **G. AUTHORITY AND RESPONSIBILITIES OF APHA JUDGES.**

A judge has the authority to place a horse in whatever position in a class he thinks the merit of the horse justifies when compared to the standards for halter classes or movement and gaits for performance classes. His/her decision shall be final in all cases in the placement of the horses in the class. Once a class has been judged it shall not be rejudged, and once the judge has marked his final record there shall be no changing of places. If clerical corrections, initiated by show official(s) (typically announcer, but could also be show secretary or manager) are made to a judge's card, they must be approved and initialed by the judge. Once a judge's placings have been announced there shall be no clerical corrections made by the judge.

1. The judge must list all contestant numbers through seven (7) entries, including disqualifications.
2. **Entry Tally.** Each judge shall be responsible for independently tallying the correct number of entries actually exhibited in each class he/she judges and marking the correct totals on a form provided by the APHA. It is the judge's responsibility to complete, sign and return this form to the APHA within ten (10) days from the show date.
3. **Eligibility Of Entries.** No judge shall determine the eligibility for registration of an entry in the ring and shall at all times refrain from making comments regarding such.
4. **Bad Conduct Of Exhibitor.** A judge may order any person or horse from the competition for bad conduct of one or both.
5. **"Sifting" Or Elimination Committee.** A Judge of any show or contest may also be on any "sifting" or elimination committee necessary.
6. **Judging Of Classes.** Only one judge may be used for any one halter class. All halter classes of one sex must be judged by the same judge. In performance classes, the use of more than one judge is optional. If more than one judge is to be used at a show, the classes to be judged by each judge shall be publicized prior to the show.

#### **H. JUDGING INSTRUCTIONS AS TO COLOR AND IDEAL STANDARD.**

1. **Individual Examination In Halter.** The judge shall make an individual examination for conformation defects, soundness and way of travel of each horse at the walk and jog-trot as it is led directly to and away from the judge and additionally the jog from a direct side angle. The judge may ask for any further individual examination he feels is

needed. Any deviation from correct leg conformation and way of going shall be penalized. The horse must move straight and true. This is essential regardless of whether the competition indicated that it is necessary or not. The walk should be a natural flat-footed four beat gait. The walk must be alert, with a stride of reasonable length for the size of the horse. The jog-trot should be a smooth ground covering two beat diagonal gait. The jog-trot should be square, balanced with straight forward movement of the feet.

2. Attire/Equipment.

- a. Disqualify. A judge shall disqualify an entry for attire and/or equipment prohibited or missing equipment required by APHA rules.
- b. Drop Bridles. The judge will be required to drop the bridles of all horses in at least one class per show.
- c. Severe Equipment. The judge may prohibit the use of bits and equipment he may consider too severe.
- d. Bits. A bit cannot be physically or mechanically changed to increase the severity of its use and may be eliminated at the discretion of the judge.
- e. Blood. In all divisions, a horse found to have blood present anywhere on its body can be disqualified at the discretion of the judge.
- f. Snaffle Bit or Hackamore. Whenever a snaffle bit or a hackamore is used on a junior horse in western events (except roping, speed events, and team penning) two hands must be used on the reins in the manner described in SC-240.D.-E.

3. Color. In all halter and performance classes, color or color patterns are not factors to be considered.

4. Ideal Standard. The ideal standard in evaluating horses in halter classes should include, but not limited to, soundness and correctness of conformation, particularly feet and legs, with emphasis on correct manner of travel. The horse should be fourteen (14) hands or taller, **or** if a stallion, should have two testicles descended; that the horse should not be gaited (rack or pace); that the biting surfaces of the upper and lower incisors should touch; and that horse should not exhibit any other physical unsoundness. If any of the above undesirable conformation traits are exhibited, or incorrectness in manner of travel, the horse shall be penalized. Obvious lameness is cause for disqualification. Obvious lameness is:

- a. Consistently observable at a trot under all circumstances.
- b. Marked nodding, hitching or shortened stride.
- c. Minimal weight-bearing in motion and/or at rest, and inability to move.

I. **COMPLAINTS AGAINST JUDGES.** To make a formal complaint against an APHA-approved judge, such complaints must be in writing, signed by the complainant, contain alleged rule violations, date and location within sixty (60) days of the show or contest. If a grievance is filed, the procedures outlined in the disciplinary procedures would be followed (See rules

GR-070.A-K.)

- J. **REMOVAL OF A JUDGE.** Removal of an individual from the Association's list of approved judges for any reason, including, but not limited to, suspension from membership, denial of Association privileges or failure to comply with Association rules, shall be absolute, with no provision for automatic reinstatement.
1. **Suspension.** Any person suspended by the APHA for cause, excepting by the automatic suspension clause for failure to pay dues and accounts, will be automatically removed from the list of approved judges and must reapply for approval in the usual manner.
  2. **Regaining Eligibility.** Upon regaining eligibility for approved judging status, the individual may apply for reinstatement after the expiration of one (1) year from the date of his qualification under the current procedures for admission of new applicant.
- K. **FAILURE TO COMPLY WITH RULE JU-000.C.2.b. & REINSTATEMENT.** If a judge is removed from the APHA approved Judge's List for failure to comply with rule JU-000.C.2.b. The judge may apply for reinstatement in the following manner:
1. **Reinstatement Fee.** Payment of a non-refundable fifty (\$50.00) dollar reinstatement fee.
  2. **Written Statement.** Stating in writing the reason or reasons the judge failed to comply with Rule JU-000.C.2.b.
  3. **References.** Submitting references from show managers of three events which the applicant has judged within two (2) years of the date the reinstatement application is submitted.
  4. **Reinstatement Approval.** Reinstatement is subject to Executive Committee approval, the Judge's Committee shall be responsible for determining whether or not a reinstatement application is approved.

## AMATEUR & NOVICE AMATEUR PROGRAMS

### AM-000. AMATEUR PROGRAM RULES AND REGULATIONS

The following Rules and Regulations shall become effective January 1 of the current year, and thereupon all Rules and Regulations and parts thereof-heretofore in force are hereby repealed.

### AM-005. INTERPRETATION OF RULES

- A. **APHA SHOULD APPLY.** For any situation not specifically covered by the Amateur program, the American Paint Horse Association (APHA) rules and regulations shall apply.

### AM-010. ELIGIBILITY

- A. **QUALIFICATION.** To qualify as an Amateur exhibitor with the APHA, an individual must meet the following requirements.
1. **Age.** An individual is considered an Amateur exhibitor when he/she is no longer eligible to show in the Youth program. For Amateur eligibility purposes, the age of an individual as of January 1 will be maintained throughout the calendar year.
  2. **Remuneration Restrictions.**
    - a. For a period of 60 months (five years) prior to the date an application for Amateur status is received in the APHA office, an applicant may not have shown, ridden, judged, trained or assisted in training a horse for remuneration, either directly or indirectly; not received remuneration for instructing another person in riding, driving or training a horse; nor received remuneration for instructing another person in showing a horse in competition.
    - b. **An individual** may not have shown, ridden, trained or assisted in training of a horse for which the **individual's spouse**, at the time, accepted any form of remuneration, either directly or indirectly, for training, assisting in training, or showing of said horse in competition for a period of 60 months (5 years) prior to the date an application for Amateur status is received in the APHA office.
    - c. **Entry Fees/Premium Money.** An individual who has had the entry fees paid or has received premium money would still be eligible for the Amateur status, however, when the Amateur exhibits a horse owned by anyone other than himself/herself or those listed in AM-020.A., the payment of expenses - per diem, lodging, transportation or mileage - shall be considered remuneration.

neration. Payment of entry fees by someone other than the immediate family shall not be considered remuneration unless entry fees were paid for service rendered. See Rule SC-160.G.2.

- d. **Amateur Status.** Amateur status may be maintained only by continual refusal of remuneration.
3. **Judges Ineligible.** Any approved horse show judge is ineligible.

## **AM-015. AMATEUR CARD APPLICATION OR RENEWAL**

A. **AMATEUR EXHIBITOR CARD.** Every exhibitor competing in an Amateur class must possess a current Amateur exhibitor card issued by the APHA. Show management must inspect the current card, photocopy of the current card, or a temporary card at each show. Application/renewal for an Amateur card shall be made on a form provided by APHA, available from them at no charge, and returned with applicable fees as provided below. A temporary Amateur card may be applied for through the show secretary at an APHA-approved show.

1. **Amateur Review Board.** All applications for Amateur exhibitor cards and all requests for renewal thereof shall be presented annually to the Amateur Review Board. Amateur exhibitor card holders will be reviewed annually at the time application for renewal is made.
2. **Falsifying an Amateur Application.** Falsifying an Amateur application will result in disciplinary action. Notice requirements and procedures for any such hearings shall be the same as those applicable under disciplinary hearing. See Rule GR-070. Upon notice and hearing, the Executive Committee may revoke the Amateur status of any person who violates any by-law, rule or regulation of the APHA. The decisions of the Executive Committee shall be final. Upon revocation of Amateur card for cause, re-application cannot be made by that individual for sixty (60) months from date of letter of final notification of Amateur status being revoked.
3. **Annual Fee.** There shall be an annual fifteen dollar (\$15.00) fee for said card. Cards are valid through December 31 of the current year.
4. **Rush Fee.** Any Amateur cards requested in less than three (3) weeks from the date they are received in the APHA office will be considered rush work and a fee of twenty-five (\$25.00), in addition to the regular fee, must accompany the application. Rush fee is non-refundable in the case an application is denied.
5. **Fax Fee.** There shall be a fee of five dollars (\$5.00) for the use of the telecopier fax to send Amateur applications, and to send Amateur cards by the same machine.
6. **Name Change.** There shall be a fee of five dollars (\$5.00) to issue an amended Amateur card to reflect the Amateur's change of name, upon request.
7. **Replacement Fee.**

- a. **Replacement.** To replace an Amateur card, written notification and a five dollar (\$5.00) replacement fee must be received in the APHA office before the replacement card will be issued. Replacement cards requested at a horse show will require the “temporary application” to be completed along with a \$30.00 fee to be submitted to the show secretary.
- b. **Non-receipt.** If an Amateur card is not received within sixty (60) days from application, written notification must be received prior to the expiration of the sixty (60) day period and/or prior to the replacement card being issued. There will be a five dollar (\$5.00) fee for replacement card unless APHA is notified of non-receipt within the sixty (60) day period specified above.

## **AM-020. OWNERSHIP**

- A. **OWNERSHIP ELIGIBILITY.** Any horse exhibited in Amateur classes at APHA-approved shows or shows sponsored by the APHA, or to qualify for the various APHA Amateur points, titles and awards, the Amateur or the Amateur’s family must be the current recorded owner of the horse. Family shall include the following: spouse, mother, father, son, daughter, brother, sister, grandchild, legal ward, inlaws (father, mother, brother, sister, son, daughter), stepchild, half brother, half sister, aunt, uncle or solely owned corporation, ranch or farm. Such ownership must be evidenced by the records of the APHA. Throughout the rest of these rules, the above shall stand as ownership requirements.
  1. **Horses Under Lease.** Horses leased to either the Amateur or the Amateur’s family are not eligible for participation in APHA-approved Amateur classes, for APHA Amateur points, and/or APHA Amateur awards.
  2. **Horses Owned in Partnership or Jointly.** Horses whose current recorded ownership is in a partnership or jointly owned by any person other than those listed above are not eligible for participation in APHA-approved Amateur classes, for APHA Amateur points, and/or APHA Amateur awards.
  3. An amateur who is the spouse of a trainer cannot show a horse for which their spouse/trainer has received remuneration for training during the six (6) month period preceding showing of the horse.
- B. **Transfer of Ownership.** The exhibitor must be able to prove ownership at the time of the show by presenting the APHA registration certificate or a legible photocopy with the correct owner or owner’s name printed on the certificate by the APHA office.

## **AM-025. APHA AMATEUR TITLES AND AWARDS**

- A. **APHA RESERVED AMATEUR TITLES AND/OR AWARDS.** All APHA Amateur Titles and/or Awards listed in

the APHA Amateur section of the APHA rule book are reserved by the APHA for its express use and will be awarded to the owner of record at the time the award is earned.

- B. **REGISTRATION REQUIREMENTS.** Titles will be awarded to any Amateur and horse, provided said Amateur and horse meet the Title/Award requirements. See Rule SC-165.A-D.
- C. **ONE HORSE-ONE AMATEUR.** Points toward all Titles and Awards will be tabulated on a one horse-one Amateur basis. In the event a horse is sold to any party other than specified in Rule AM-020., any points earned are not transferable and a new start **in acquiring points** must be made by the new owner.
- D. **ELIGIBILITY.** The Amateur must meet eligibility and ownership requirements. See Rule AM-010 and AM-020. and the requirements of the Title/Award.
- E. **POINT ACCUMULATION.** Amateur points will be awarded as outlined in Rule SC-060.A. An Amateur may exhibit more than one horse; however, the points earned by the Amateur with each horse will be compiled separately.
- F. **APHA RECORD NOTATION.** Proper notation shall be made of all APHA Amateur Titles/Awards issued in the records of the APHA.
- G. **FRAUDULENT CLAIMS OR ADVERTISING OF APHA TITLES OR AWARD.** The registration certificate of any horse may be revoked permanently by the APHA if the owner thereof fraudulently advertises, claims or holds forth that a certain Amateur/horse is entitled to a title and/or award prior to the title and/or award being officially awarded by the APHA.

#### **AM-030. PERFORMANCE CONTEST CATEGORIES**

- A. **CATEGORIES.** The following performance contests have been divided into *six* categories and are approved for points and/or awards. **Exception:** Novice Amateur classes categorized in Rule AM-225. do not qualify for the aforementioned Amateur Titles and/or Awards.
  - 1. Category I
    - a. Barrel Racing
    - b. Pole Bending
    - c. Stake Race
    - d. Goat Tying
    - e. Team Penning
  - 2. Category II
    - a. Reining
    - b. Western Riding
    - c. Working Cow Horse
    - d. Trail
    - e. Utility Driving
  - 3. Category III
    - a. Working Hunter
    - b. Hunter Hack
    - c. Jumping
  - 4. Category IV
    - a. Cutting
    - b. Calf Roping

- c. Team Roping Heading
  - d. Team Roping Heeling
  - e. Steer Stopping
  - f. Breakaway Roping
5. Category V
    - a. Hunter Under Saddle (BPH)
    - b. Pleasure Driving
    - c. Western Pleasure
  6. Category VI
    - a. Hunt Seat Equitation
    - b. Showmanship
    - c. Western Horsemanship

### **AM-035. APHA SUPERIOR AMATEUR CHAMPION AWARD**

- A. **TITLE.** The title of APHA Superior Amateur Champion will be awarded to any Amateur/horse who meet the qualifying rules of AM-010. and AM-020. and this Title/Award requirements. This award shall be retroactive.
- B. **NO TIME LIMIT.** Points toward the APHA Superior Amateur Championship need not be earned in any one year.
- C. **Total Points.** The Amateur/horse have won a total of at least 270 points, see Rule SC-060 for method of tabulation, in recognized Amateur halter and performance classes in APHA-approved "A" shows.
  1. **Halter.** At least 30 of those points have been won in Amateur halter classes and of the 30 a maximum of 15 points may be earned in the yearling year.
  2. **Performance.** At least 240 of those points have been won in Amateur performance classes.
  3. **Superior Event.** Have earned a Superior in four (4) of the six (6) categories.
  4. **ROM Requirement.** Have earned a ROM in four (4) of the six (6) categories in an event other than that in which the qualifying Superiors were won.
- D. **TROPHY.** In the event that this Title is awarded, a special and properly engraved trophy shall be prepared and presented to the Amateur exhibitor of the said horse at the next annual convention of the APHA or Amateur Banquet. A proper notation shall be made in applicable records of the APHA.

### **AM-040. APHA AMATEUR CHAMPION AWARD**

- A. **TITLE.** The title of APHA Amateur Champion will be awarded to any Amateur/horse which meet the qualifying Rules AM-010. and AM-020. and the requirements of the Title/Award.
- B. **NO TIME LIMIT.** Points toward the APHA Amateur Champion need not be earned in any one year.
- C. **POINTS.** The Amateur/horse must have earned a total of forty or more points, see Rule SC-060, must have been won in Amateur competition in official shows recognized by the APHA provided:
  1. **Shows and Judges.** That the points have been won in five

- (5) or more Amateur shows or contests and under five (5) or more judges.
2. **Halter.** That at least sixteen (16) points have been won in Amateur halter classes and of these sixteen (16), a minimum of ten (10) points must have been won in either A or B rated shows. See Rules SC-055 and SC-060. Exception: Points shall be awarded to yearlings in their respective halter classes with a maximum of 10 halter points to qualify for a Championship.
  3. **Performance.** That at least sixteen (16) of these points have been won in Amateur Performance classes or contests, and with a minimum of five (5) points each have been earned in at least two (2) categories of Amateur performance events and cannot be earned in a combination of categories, as set forth in Rule AM-030. NOTE: Only Categories I through V will be used for tabulation of the sixteen (16) Amateur performance points for an Amateur Champion.
  4. **Remaining Points Needed.** The remaining eight (8) points may be earned in any Amateur events listed. See Rule AM-090 and AM-095.
- D. **AWARD.** In the event that the title of APHA Amateur Champion is awarded, an appropriate award shall be prepared for the Amateur exhibitor by the APHA office.

#### **AM-045. APHA AMATEUR PERFORMANCE VERSATILITY AWARD**

- A. **TITLE.** The title of APHA Amateur Performance Versatility will be awarded to an Amateur/horse which meet the qualifying Rules AM-010. and AM-020. and the Title/Award requirements.
- B. **NO TIME LIMIT.** Points toward the Amateur Performance Versatility need not be earned in any one year.
- C. **ROM'S.** To earn the title of APHA Amateur Performance Versatility, five (5) ROM's must have been earned of which one ROM must have been earned in at least one of the following: Showmanship at Halter, Western Horsemanship (Equitation), or Hunt Seat Equitation; only one is required, but all three may be used for the award.
- D. **SUPERIOR RATING.** A superior rating must have been achieved in one of the five (5) events in which a ROM was earned.
- E. **AWARD.** In the event the title of APHA Amateur Performance Versatility is awarded, a properly prepared certificate and lifetime show record will be presented by the APHA office.

#### **AM-050. APHA AMATEUR SUPERIOR EVENT AWARD**

- A. **TITLE.** The title of APHA Amateur Superior Event will be awarded to any Amateur/horse which meet the qualifying Rules AM-010. and AM-020. and the Title/Award require-

ments.

- B. **NO TIME LIMIT.** Points toward the APHA Superior Event need not be earned in any one year.
- C. **POINTS.** To earn the title of APHA Amateur Superior Event the Amateur/horse must have earned fifty (50) or more points in one APHA approved event.
  - 1. **Each Separate Event.** An Amateur/horse may receive this title for each separate event in which they have earned fifty (50) points. See Rule SC-060.A.
- D. **CERTIFICATE.** When the title of APHA Amateur Superior Event is awarded, a proper certificate shall be prepared for the Amateur exhibitor by the APHA office.

#### **AM-055. APHA AMATEUR REGISTER OF MERIT AWARD**

- A. **TITLE.** The title of APHA Amateur Register of Merit will be awarded to any Amateur/horse which meet the qualifying rules of AM-010. and AM-020. and the Title/Award requirements.
- B. **PURPOSE.** The purpose of the Register of Merit is to establish a record of excellence.
- C. **NO TIME LIMIT.** Points toward the APHA Amateur Register of Merit need not be earned in any one year.
- D. **POINTS.** The Amateur/horse are advanced to the Register of Merit when they have competed in one or more of the APHA-approved Amateur contests shown in Rule AM-030. and have won at least ten (10) points in any one event as outlined in the scale of points for contests. See Rule SC-060.
- E. **CERTIFICATE.** When the title of Amateur Register of Merit is awarded, a proper certificate shall be prepared for the Amateur exhibitor by the APHA office.

#### **YEAR-END AWARDS**

##### **AM-060. APHA AMATEUR TOP TWENTY AWARD**

- A. **TITLE.** The title of APHA Amateur Top Twenty will be awarded to any Amateur/horse which meet the qualifying Rules AM-010. and AM-020. and the Title/Award requirements.
- B. **YEAR-END AWARDS.** Year-end awards will be given to the twenty Amateurs who earn the most points with one horse in Amateur halter and performance classes. A contestant may exhibit more than one horse; however, the points earned by the Amateur with each horse will be compiled separately.
  - 1. **Time Period.** Total Amateur points will be compiled on Amateur exhibitors from January 1 through December 31 of each year.
  - 2. **Points.** Points will be awarded on the same basis used in the Open division. See Rule SC-060.
  - 3. **Maximum Number of Shows and Judges.** A maximum of 20 APHA-approved shows, all under different judges, from which their total points will be tabulated.
  - 4. **Tie Breaker System.**

- a. One alternate show will be used in case of a tie.
  - b. The judge of this show will be different from the other show judges.
- D. **AWARD.** When the titles of APHA Top Twenty are awarded, buckles shall be prepared and presented to the Amateurs by the APHA office.

#### **AM-065. APHA AMATEUR HONOR ROLL AWARD**

- A. **TITLE.** The title of APHA Amateur Honor Roll will be awarded to any Amateur/horse which meet the qualifying Rules AM-010. and AM-020. and the Title/Award requirements.
- B. **ELIGIBILITY/POINTS.** The ten Amateurs and their horses earning the most points in each Amateur event during each calendar year from January 1 through December 31 each year will be awarded the title. In order to be eligible for this award, a minimum of eight (8) points must be earned.
- C. **AWARD.** The Amateur earning the most points in each Amateur event during one calendar year will receive an appropriate award.
- D. **CERTIFICATES.** The Amateurs and their horses placing second through tenth in each Amateur event will receive an appropriate certificate.

#### **AM-070. APHA AMATEUR ZONE AWARD**

- A. **TITLE.** The title of APHA Amateur Zone will be awarded to an Amateur/horse which meet the qualifying Rules AM-010. and AM-020. and the Title/Award requirements.
- B. **POINTS.** This award would recognize the top five Amateurs and their horses living in each of the zones found on the APHA Zone Map. This award is based on total cumulative points earned within their respective zones from January 1 to December 31 each year. See rule SC-105.B.3.f-g. for states, provinces and countries listed in the respective zones.
- C. **TIEBREAKER SYSTEM.**
- 1. **Performance Points.** Amateur with the greatest number of performance points.
  - 2. **Fewest Shows.** The most points earned in the fewest number of shows.
- D. **AWARDS.** First place will receive an appropriate award. First through fifth place will receive a proper certificate.

#### **AM-071. ROOKIE OF THE YEAR AWARD**

- A. To be eligible for the award:
- 1. The exhibitor cannot have won any equine association points (in open, youth, amateur or novice) at any time prior to the year of the award.
  - 2. The exhibitor is a first time APHA amateur card holder.
  - 3. First time amateur card holders who have earned APHA youth points are not eligible for this award.
- B. All eligible exhibitors must hold a current year amateur status

card and must be a current member of the APHA according to Rule GR-020.K.

- C. This award is based on total points accumulated on a one-horse/one-amateur basis per calendar year, and the horse's ownership must meet the requirements of Rule AM -020.
  - 1. Only one rookie of the year will be awarded but will include both amateur and novice amateur divisions.
- D. Tiebreaker:
  - 1. To the person winning points in the greatest number of different events.
  - 2. To the person with the greatest number of wins.
- E. An appropriate award will be awarded by the APHA.

### AM-075. SHOW APPROVAL RULES

- A. **TO GAIN SHOW APPROVAL.** A show and/or each approved event must be open to all APHA Amateur exhibitors in good standing to gain APHA approval. All exhibitors in Amateur classes are required to hold a current APHA Amateur Exhibitor Card.
  - 1. **Minimum Classes Offered.** A show offering Amateur classes must offer a minimum of three halter and three performance classes. Exception: State Fairs and Livestock shows.
- B. **CLASSIFICATION OF SHOW.** Entries in Amateur classes will count toward the classification of the show.
- C. **ORDER OF JUDGING AMATEUR CLASSES.** Amateur classes may be judged before or after the corresponding Open and/or Youth classes (i.e., Youth Western Pleasure, Jr Western Pleasure, Sr Western Pleasure and Amateur Western Pleasure).
- D. **AMATEUR AND YOUTH/AMATEUR SHOWS.** All Amateur or Youth/Amateur Shows may be held separate from and independent of the APHA Open shows.
- E. **MULTIPLE JUDGED SHOWS.** Each *regional club* in the United States, Canada, or an *international* country is eligible for one set of all Amateur or one set of combined Youth/Amateur multi-judged shows per year. See Rule SC-105.
- F. **APPROVAL/APPLICATIONS.** See Rule SC-090.A-N.
- G. **RESULTS.** See Rules SC-125.A-F.
- H. **JUDGES.** See Rules JU-000. A-K.

### AM-080. AMATEUR AGE DIVISIONS

- A. **RECOGNIZED DIVISIONS.** The APHA recognizes the following age divisions for Amateurs.
  - 1. **One Age Group Offered.** If one age group class is offered it should be for all eligible Amateurs.
  - 2. **Two Age Divisions Offered.** If two classes are offered, they should be held for 19-44 and 45 and older.
  - 3. **Performance Classes.** *Western Pleasure and Hunter Under Saddle may be split according to the horses' age, Jr. & Sr., as done in open performance classes. See Rule SC-185.G.*
- B. **COMBINING OR SPLITTING AGE GROUPS.** Show management may combine or split age groups of Amateur

exhibitors as justified by entries if there is unanimous consent of all involved exhibitors, however, if one division is not a point earning class, then show management may combine age groups without unanimous consent of all exhibitors in order to make the division a point earning class.

### **AM-085. AMATEUR GENERAL SHOW RULES**

- A. **HORSES PROPERLY REGISTERED.** An Amateur exhibitor must be able to prove that the horse exhibited is properly registered with the APHA at the time the horse is being shown.
- B. **STALLIONS.** Stallions are eligible to show in amateur events.
- C. **ENTRY WITHDRAWAL.** See Rule SC-175.A. and SC-185.A.
- D. **ERRORS IN ENTRY.** The exhibitor is responsible for errors on the entry blank. A horse entered in the wrong class may be transferred to its correct class after the judging program has been printed.
- E. **CONTESTANTS EXHIBITING THE SAME HORSE.** A horse may not be shown by more than one exhibitor in the same event or compete more than once in the same event regardless of Amateur age divisions. **Example:** A horse being exhibited in Western Horsemanship (19-44) may not be exhibited in Western Horsemanship (45 and older).
- F. **RIDING TWO HORSES.** An exhibitor may exhibit a maximum of two horses in the following individual working events: barrel racing, breakaway roping, calf roping, cutting, team penning, goat tying, jumping, pole bending, reining, stake race, steer stopping, team roping heading, team roping heeling, trail, utility driving, western riding, working cowhorse and working hunter. Each horse may have only one rider or driver per class.
- G. **REQUEST BY JUDGE TO CHANGE HORSES.** The judge may **not** ask the Amateur exhibitor to change horses with another Amateur exhibitor in any amateur events.
- H. **SITUATIONS/EVENTS NOT SPECIFICALLY STATED.** FOR ANY SITUATIONS/EVENTS NOT COVERED BY AMATEUR PROGRAM RULES AND REGULATIONS, THE RULES AND REGULATIONS APPLYING TO APHA APPROVED SHOWS AND CONTEST RULES SHALL APPLY. EXAMPLES:
  - 1. **UNSPORTSMANLIKE CONDUCT.** See Rule GR-040.G.
  - 2. **GO-ROUNDS.** See Rule SC-185.J.
  - 3. **HACKAMORE/SNAFFLE BITS.** See Rule SC-240.D.E.

### **AM-090. HALTER**

- A. **JUDGING PRIOR TO GRAND AND RESERVE.** Halter classes must be offered for all sex divisions. All halter classes of any sex division must be judged prior to Open Grand and Reserve of that sex division.
- B. **POINTS.** Points will be awarded as outlined in Rule SC-060.

**Exception:** In Amateur Showmanship at Halter and Amateur Halter classes, points shall be awarded to any Amateur and horse, regardless of horse's age, (except weanlings) provided the Amateur meets eligibility and ownership requirements, Rules AM-010. & AM-020.A., and the horse meets registration requirements. See Rules RG-010.B. and SC-165.A.B.

1. **Geldings.** In Amateur Halter, geldings which are still listed as stallions according to APHA records at the time the show results are processed at the APHA office will be disqualified.
- C. **APPROVED REGULAR REGISTRY CLASSES.** The following is a list of approved Amateur halter classes.
1. **Individual Classes.**
    - a. Stallions, All Ages.
    - b. Mares, All Ages.
    - c. Geldings, All Ages.
  2. **Junior and Senior Classes may be Offered.**
    - a. Junior Stallions, Ages 3 and under.
    - b. Senior Stallions, Ages 4 and over.
    - c. Junior Mares, Ages 3 and under.
    - d. Senior Mares, Ages 4 and over.
    - e. Junior Geldings, Ages 3 and under.
    - f. Senior Geldings, Ages 4 and over.
  3. **Separate Age Classes for Stallions, Mares and Geldings.**
    - a. Current year foals.
    - b. Yearlings.
    - c. Two Year Olds.
    - d. Three Year Olds.
    - e. Four Year Olds and over.
- D. **BREEDING STOCK HALTER CLASSES.**
1. **Approved Classes.**
    - a. Breeding Stock Stallion, All ages.
    - b. Breeding Stock Mares, All Ages.
    - c. Breeding Stock Geldings, All Ages.
- E. There will be no grands or reserves awarded in the Amateur Halter division.

## **AM-095. PERFORMANCE AND EQUITATION CLASSES**

- A. **POINTS.** See Rule SC-060.
- B. **EQUITATION.**
1. Hunt Seat Equitation.
  2. Western Horsemanship (Equitation).
- C. **APPROVED PERFORMANCE EVENTS.**
1. Barrel Racing.
  2. Breakaway Roping.
  3. Calf Roping.
  4. Cutting.
  5. Goat Tying.
  6. Hunter Hack.
  7. Hunter Under Saddle (BPH).
  8. Jumping.
  9. Pleasure Driving.
  10. Pole Bending.

11. Reining.
12. Showmanship at Halter.
13. Stake Race.
14. Steer Stopping.
15. Team Penning.
16. Team Roping, Heading.
17. Team Roping, Heeling.
18. Trail.
19. Utility Driving.
20. Western Pleasure.
21. Western Riding.
22. Working Cowhorse.
23. Working Hunter.

**D. BREEDING STOCK PERFORMANCE.**

1. Calf Roping.
2. Cutting.
3. Hunter Under Saddle (BPH)
4. Reining.
5. Trail.
6. Showmanship at Halter.
7. Western Pleasure.
8. Western Riding

**FOR RULES TO APPROVED AMATEUR EVENTS NOT LISTED IN THIS AMATEUR SECTION, REFER TO THE CORRESPONDING OPEN EVENT IN THE SHOW & CONTEST SECTION OF THIS RULE BOOK.**

**AM-100. APHA SHOW ALL-AROUND  
AMATEUR AWARD**

- A. **NOT MANDATORY.** It is not mandatory for an all-around Amateur award to be made at an APHA approved show; however, if such an award is offered, it must be based on a one-Amateur, one horse combination.
- B. **ELIGIBILITY.** All approved Amateur classes, including halter, will count equally towards this award, **but** in order to be eligible to receive this award, the contestant must show in at least three Amateur performance classes. No particular class may be considered mandatory. See Rule SC-145.A.2-4.
- C. **POINTS.** Points will be compiled according to Rule SC-145.A.2-4.

**AM-105. AMATEUR SHOWMANSHIP AT HALTER**

- A. **ATTIRE.**
  1. Suitable western attire should be worn as outlined by Rule SC-235.A. Exception: Spurs, chinks, or chaps must not be worn.
  2. A clean well fitting halter with an appropriate lead is required.
- B. **CLASS DESCRIPTION.**
  1. The showmanship class is not another halter class and should not be judged as such. The class shall be judged

strictly on the exhibitor's ability to fit and show a horse at halter. The horse is merely a prop to demonstrate the ability and preparation of the exhibitor. The ideal showmanship performance consists of a poised, confident neatly attired exhibitor leading a well conditioned and groomed horse that performs the requested pattern with smoothness, willingness and precision.

2. A pattern shall be posted with sufficient time for exhibitors to review prior to the commencement of their class. If there is a finals pattern, it also shall be posted at the same time.

#### **C. CLASS PROCEDURES.**

1. The judge may ask exhibitors to enter the ring and then work individual or work their patterns starting from the gate.
2. The following maneuvers are considered acceptable:
  - a. Lead the horse at a walk and trot.
  - b. Stops.
  - c. Turns of 90 (1/4), 180 (1/2), 270 (3/4), 360 (full turn) degrees or any combination or multiple of these turns.
  - d. Back in a straight or curved line.
3. The judge must have each exhibitor set the horse up squarely for inspection during the class.
4. Horses may be lined up side by side or head to tail.

#### **D. JUDGING POINTS.**

1. Appearance of the exhibitor should be neat, clean and appropriate western wear must be worn.
2. Appearance of Horse: The horse should appear fit and well conditioned. The hair coat should be clean and well brushed. The mane and tail should be clean and tangle free. The mane may be banded or braided, but it is not mandatory. It is acceptable to roach the mane but the forelock and tuft over the withers should be left. The bridle path, eyebrows and long hairs on the head and legs should be clipped, except where government regulations prohibit. The inside of the ears may be clipped. Hooves should be properly trimmed and if shod, the shoes should fit correctly and clinches should be neat. Hooves should be clean and may be painted black, brown or clear, with hoof dressing, or be shown naturally. Tack should fit properly and be neat, clean and in good repair.
3. Performance.
  - a. Exhibitors should be poised, confident, courteous and sportsmanlike at all times. The exhibitor should continue showing the horse, correcting faults in the positioning of the horse until the class has been placed or excused.
  - b. The exhibitor must lead on the horse's left side holding the lead shank in the right hand near the halter with the tail of the lead held in the left hand. Exhibitor should not hold on to the chain portion of the lead shank. The excess lead should never be tightly coiled or drag the ground, but should be folded loosely coiled. The exhibitor should maintain this hand positioning for the entire class unless requested by the judge to show the

horse's teeth. Leading, backing, turning and initiating the set up should be performed from the left side of the horse. The exhibitor should never stand directly in front of their horse.

- c. The stop should be straight, smooth and responsive with the horse's body remaining straight.
  - d. The exhibitor should face the horse when backing. The horse should back up readily with the head, neck and body aligned in a straight or curved line as instructed.
  - e. When executing a turn to the right the exhibitor should face the horse and move the horse away from them. On turns of less than 90 degrees it is acceptable to lead the horse toward them. On turns of 90 degrees or greater the horse should pivot on the right or left hind leg while stepping across with the front legs.
  - f. The horse should set up quickly with the hooves squarely underneath the body. The exhibitor does not have to reset a horse that stops square. The exhibitor should stand angled toward the horse, use only the lead shank to achieve the set up and never leave the horse's head. The exhibitor should never stand directly in front of their horse, touch the horse with their hands or feet, or visibly cue the horse by pointing their feet at the horse's hooves during set up. It is recommended, but not mandatory, that exhibitors use the "Quarter Method" when presenting their horse. The exhibitor should maintain a position that is safe for themselves and the judge. The position of the exhibitor should not obstruct the judge's view of the horse and allow the exhibitor to maintain awareness of the judge's position at all times. The exhibitor should not crowd other exhibitors when lining up. When moving around the horse the exhibitor should change sides in front of the horse and assume the same position on the right side of the horse that they had on the left side.
4. Faults.
- a. Minor Faults. Poorly groomed, conditioned or trimmed horse. Dirty, ragged or ill-fitting halter or lead. Improper position by the exhibitor. Excessively stiff, artificial or unnatural movement around the horse or when leading. Excessive use of verbal cues. Continuous holding of the chain portion of the lead. Lead shank tightly coiled around hand or dragging the ground. Taking hands off of lead or changing hands on the lead, except when showing the horse's teeth. Drifting of the horse when led. Horse stops crooked or drops a hip out when stopping, setting up or standing. Leading, backing, or turning sluggishly or crooked. Horse not set up squarely or excessive time is required to set up. Failure to maintain a pivot foot during turns. Failure to perform maneuvers at designated markers, but horse is on pattern.
  - b. Major Faults. (Avoids disqualification but should not place above exhibitors that do not incur a major fault.)

- Complete failure to move around horse by the exhibitor and obstructing the judge's view. Exhibitor touching the horse or kicking or pointing their feet at the horse's hooves during set up. Standing directly in front of the horse. Omission or addition of maneuvers. Knocking over a cone. Working on wrong side of cones.
5. Disqualifications. (Must not be placed.) Horse escapes from exhibitor. Failure of exhibitor to wear correct number in a visible manner. Any physical abuse of the horse. Excessive schooling or training. Improper attire. Loss of control or severe disobedience that endangers others to include but not limited to: biting, pawing, rearing, kicking out or continuously circling the exhibitor. Leading on the wrong side of the horse.

## AM-110. AMATEUR HUNT SEAT EQUITATION

### A. ENGLISH APPOINTMENTS.

1. **English Attire.** See Rule SC-195.A. **Exception:** The wearing of a safety helmet is optional. See equipment and attire chart in back of rule book.
2. **English Tack.** See Rule SC-200.

*B. Equitation. Hunt seat equitation on the flat is an evaluation based on the ability of a rider to perform various maneuvers in harmony with his/her horse. The communication between horse and rider through subtle cues and aids should not be obvious. Equitation is judged on the rider and his/her effect on the horse. Hunt seat equitation on the flat provides a base for a natural progression to over fence classes.*

*C. Pattern. It is mandatory that the judge post the pattern at least one hour prior to commencement of the class. The pattern should be designed so the majority of exhibitors can perform it in a reasonable length of time (under 60 seconds). All patterns must include a trot and canter. Horses' gaits are to be ridden with the same cadence and speed as you would find in the rail phase. All ties will be broken at the discretion of the judge. Failure to complete the pattern will not be a disqualification, but shall be scored accordingly.*

*D. Class Procedure. Exhibitors may be worked individually from the gate or they may all enter at once but a working order must be drawn regardless. The entire class, or only the finalists, may work at all three gaits at least one direction of the arena. Rail work can be used to break ties and possibly adjust placings. Individual works may be comprised of any of the following:*

1. *Group #1: Walk, sitting Trot, Extended Trot, Posting Trot, Canter, Circles, Figure 8, Halt, Back, Sidepass, Address Reins, Demonstrate Change of diagonal.*
2. *Group #2: Serpentine (Trot or Canter), Turn on Haunches or Forehand, Leg Yield, Flying or Simple Change of Lead.*
3. *Group #3: Canter and Hand Gallop in a straight or curved line, Counter Canter Figure 8, Drop or Pick-up irons without stopping, Dismount and Mount.*
  - a. *A turn on the forehand to the right is accomplished by moving haunches to the left.*

- b. *A forehand turn to the left is accomplished by moving haunches to the right.*
  - c. *If riders are asked to drop their irons, they can leave them down or cross them over the withers.*
- E. *Basic Position.*
1. *To mount, take up reins in left hand and place hand on withers. Grasp stirrup leather with right hand and insert left foot in stirrup and mount. To dismount, rider may either step down or slide down. The size of rider must be taken into consideration.*
  2. *Hands should be over and in front of horse's withers, knuckles thirty degrees inside the vertical, hands slightly apart and making a straight line from horse's mouth to rider's elbow. Method of holding reins is optional, and bight of reins may fall on either side. However, all reins must be picked up at the same time.*
  3. *The eyes should be up and shoulders back. Toes should be at an angle best suited to rider's conformation; heels down, calf of leg in contact with horse. Iron should be on the ball of the foot and must not be tied to the girth.*
- F. *The Walk. Should be a 4-beat gait with the rider in a vertical position with a following hand.*
- G. *The Posting Trot. Figure 8 at trot, demonstrating change of diagonals. At left diagonal, rider should be sitting the saddle when left front leg is on the ground; at right diagonal rider should be sitting the saddle when right front leg is on the ground; when circling clockwise at a trot, rider should be on left diagonal; when circling counter-clockwise, rider should be on right diagonal. The rider should close his/her hip angle to allow his/her torso to follow the horizontal motion of the horse. The upper body should be inclined about 20 degrees in front of the vertical.*
- H. *Sitting Trot and Canter. At the sitting trot the upper body is only slightly in front of the vertical. At the canter the body should be positioned slightly more in front of the vertical. As the stride is shortened, the body should be in a slightly more erect position.*
- I. *Two Point Position. The pelvis should be forward, but relaxed, lifting the rider's weight off the horse's back and transferring the weight through the rider's legs. In this position the two points of contact between horse and rider are the rider's legs. Hands should be forward, up the neck, not resting on the neck.*
- J. *Hand Gallop. A three-beat, lengthened canter ridden in two-point position. The legs are on the horse's sides while the seat is held out of the saddle. When at the hand gallop, the rider's angulation will vary somewhat as the horse's stride is shortened and lengthened. A good standard at a normal hand gallop should be about 30 degrees in front of the vertical.*
- K. *Suggested Scoring. Scoring may be on a basis of 0-20 with 1/2-point increments acceptable, an approximate breakdown follows:*
1. *Score of 20: Excellent equitation including body position and use of aids. Pattern is performed promptly, precisely and smoothly.*
  2. *Score of 18-19: Generally excellent performance with one minor fault in appearance and position of exhibitor or exe-*

- cution of the pattern (performance.)*
3. *Score of 16-17: Generally good pattern execution and equitation with one minor fault in precision or execution of pattern (performance) or appearance and position of exhibitor.*
  4. *Score of 14-15: Average pattern that lacks quickness or precision, or rider has obvious equitation flaws that prevent effective equitation, or commits two or three minor faults in the performance or appearance and position of exhibitor.*
  5. *Score of 12-13: One major fault or several minor faults in the performance or appearance and position of exhibitor that precludes effective communication with the horse.*
  6. *Score of 10-11: Two major faults or many minor faults in the performance or appearance and position of exhibitor.*
  7. *Score of 6-9: Several major faults or one severe fault in the performance or appearance and position of exhibitor. Exhibitor demonstrates a complete lack of riding ability or commits a severe fault in the performance or appearance and position of exhibitor.*
  8. *Score of 1-5: Exhibitor commits one or more severe faults in the performance or appearance and position of exhibitor, but does complete the class and avoids disqualification.*

## **AM-115. AMATEUR WESTERN HORSEMANSHIP EQUITATION**

- A. **WESTERN TACK AND ATTIRE.** See Rule SC-235. and SC-240. **Exception:** Exhibitor's wearing of a safety helmet and legwraps and/or boots on horse are optional at exhibitor's discretion.
- B. *Equitation.*
1. *The western horsemanship class is designed to evaluate the rider's ability to execute, in concert with their horse, a set of maneuvers prescribed by the judge with precision and smoothness while exhibiting poise and confidence, and maintaining a balanced, functional, and fundamentally correct body position. The ideal horsemanship pattern is extremely precise with the rider and horse working in complete unison, executing each maneuver with subtle aids and cues.*
  2. *It is mandatory that the judge post any pattern(s) to be worked at least one hour prior to the commencement of the class; however, if the judge requires additional work of exhibitors for consideration of final placing, the pattern may be posted. Pattern(s) should be designed to test the horseman's ability. All ties will be broken at the judge's discretion.*
- C. *Class Procedures.* All exhibitors must enter the ring and then work individually or each exhibitor may be worked from the gate individually. When exhibitors are worked individually from the gate, a working order is required. Exhibitors should be instructed to either leave the arena, fall into line, or fall into

place on the rail after their work. The whole class, or just the finalists, may work at all three gaits at least one direction of the arena.

1. *The following maneuvers are acceptable in a pattern: walk, jog, trot, extended trot, lope, or extended lope in a straight line, curved line, serpentine, circle, or figure 8, or combination of these gaits and maneuvers; stop; back in a straight or curved line; turn or pivot, including spins and rollbacks on the haunches and/or on the forehand; side pass, two track, or leg yield; flying or simple change of lead; counter canter; or any other maneuver; or ride without stirrups. A back should be asked for at sometime during the class. Judges should not ask the exhibitors to mount or dismount.*
2. *Suggested Scoring. Scoring may be on a basis of 0 to 20 with 1/2 point increments acceptable. Ten points should be allocated toward overall appearance of exhibitor and horse and 10 points allocated toward performance of the pattern.*
3. *Overall Appearance of Exhibitor and Horse (10 points): The exhibitor's overall poise, confidence, appearance, and position throughout the class as well as the physical appearance of the horse will be evaluated.*
  - a. *Appearance and Position of Exhibitor. Appropriate western attire must be worn. Clothes and person are to be neat and clean.*
  - b. *Position of Exhibitor. The exhibitor should appear natural in the seat and ride with a balanced, functional, and correct position regardless of the maneuver or gait being performed. During the railwork and pattern the exhibitor should have strong, secure, and proper position. Exhibitors should sit and maintain an upright position with the upper body at all gaits. The rider should sit in the center of the saddle and the horse's back with the legs hanging to form a straight line from the ear, through the center of the shoulder and hip, touching the back of the heel or through the ankle. The heels should be lower than the toes, with a slight bend in the knee and the lower leg should be directly under the knee.*
    1. *The rider's back should be flat, relaxed and supple. An overly stiff and/or overly arched lower back will be penalized. The shoulders should be back, level and square. The rider's base of support should maintain secure contact with the saddle from the seat to the inner thigh. Light contact should be maintained with the saddle and horse from the knee to mid-calf. The knee should point forward and remain closed with no space between the exhibitor's knee and the saddle. The exhibitor will be penalized for positioning the legs excessively behind or forward of the vertical position. Regardless of the type of stirrup, the feet may be placed home in the stirrup, with the boot heel*

*touching the stirrup, or may be placed with the ball of the foot in the center of the stirrup. The rider's toes should be pointing straight ahead or slightly turned out with the ankles straight or slightly broken in. Riding with toes only in the stirrup will be penalized. Those exhibitors that can maintain the proper position throughout all maneuvers should receive more credit. When riding without stirrups, the exhibitor should maintain the same position as previously described.*

- 2. Both hands and arms should be held in a relaxed, easy manner, with the upper arm in a straight line with the body. The arm holding the reins should be bent at the elbow forming a line from the elbow to the horse's mouth. The free hand and arm may be carried bent at the elbow in a similar position as the hand holding the reins or straight down at the rider's side. Excessive pumping of the free arm as well as excessive stiffness will be penalized. The rider's wrist is to be kept straight and relaxed, with the hand held at about 30 to 45 degrees inside the vertical. The rein hand should be carried immediately above or slightly in front of the saddle horn. The reins should be adjusted so that the rider has light contact with the horse's mouth, and at no time shall reins require more than a slight hand movement to control the horse. Excessively tight or loose reins will be penalized.*
- 3. The rider's head should be held with the chin level and the eyes forward, and may be directed slightly toward the direction of travel. Excessive turning of the head to the inside of the circle, or down at the horse's head or shoulder will be penalized.*
- 4. The exhibitor should not crowd the exhibitor next to or in front of them when working on the rail and should pass to the inside of the arena. When reversing on the rail, the exhibitor should always reverse to the inside of the arena.*

*D. Appearance of Horse. The horse's body condition and overall health and fitness should be assessed. The horse should appear fit and carry weight appropriate for the body size. A horse which appears sullen, dull, lethargic, emaciated, drawn, or overly tired should be penalized according to severity. Tack should fit the horse properly and be neat, clean and in good repair.*

*E. Performance (10 Points). The exhibitor should perform the work accurately, precisely, smoothly, and with a reasonable amount of promptness. Increasing speed of the maneuvers performed increases the degree of difficulty, however, accuracy and precision should not be sacrificed for speed. Exhibitors that perform the pattern sluggishly and allow their horse to move without adequate impulsion, collection, or cadence will be penalized. The horse should perform all maneuvers in the pattern willingly, briskly, and readily with minimal visible or audible cueing.*

1. *Failure to follow the prescribed pattern, knocking over or working on the wrong side of the cones, or severe disobedience will not result in a disqualification, but should be severely penalized and the exhibitor should not place above an exhibitor that completes the pattern correctly.*
  2. *Excessive schooling or training, or willful abuse by the exhibitor is cause for disqualification.*
  3. *The horse should track straight, freely, and at the proper cadence for the prescribed gait. Transitions should be smooth and prompt in the pattern and on the rail, and should be performed when called for on the rail. The horse's head and neck should be straight and in line with its body while performing straight lines and slightly arched to the inside on curved lines or circles. Circles should be round, and performed at the appropriate speed, size, and location as requested in the pattern. The counter-canter should be performed smoothly with no change in cadence or stride unless specified in the pattern.*
  4. *The stop should be straight, square, prompt, smooth, and responsive with the horse maintaining a straight body position throughout the maneuver. The back should be smooth and responsive.*
  5. *Turns should be smooth and continuous. When performing a turn on the haunches, the horse should pivot on the inside hind leg and step across with the front legs. A rollback is a stop and 180 degree turn over the hocks with no hesitation. Backing during turns will be penalized severely.*
  6. *The horse should step across with the front and hind legs when performing the sidepass, leg yield, and two track. The sidepass should be performed with the horse keeping the body straight while moving directly lateral in the specified direction. When performing a leg yield, the horse should move forward and lateral in a diagonal direction with the horse's body arced opposite to the direction that the horse is moving. In the two track, the horse should move forward and lateral in a diagonal direction with the horse's body held straight or bent in the direction the horse is moving.*
  7. *A simple or flying change of lead should be executed precisely in the specified number of strides and/or at the designated location. A simple change of lead is performed by breaking to a walk or trot for one to three strides. Flying changes should be simultaneous front and rear. All changes should be smooth and timely.*
  8. *Position of the exhibitor and performance of the horse and rider on the rail must be considered in the final placing.*
- F. *Faults. Faults can be classified as minor, major or severe. The judge will determine the appropriate classification of a fault based upon the degree and/or frequency of the infraction. A minor fault will result in a 1/2 to 4 point deduction from the exhibitor's score. A major fault will result in a deduction of 4 1/2 points or more from the exhibitor's score. An exhibitor that incurs a severe fault avoids elimination, but should be placed below all other exhibitors that complete the pattern correctly. A minor fault can become a major fault and a major fault can become a severe fault*

when the degree and/or frequency of the infraction(s) merits.

1. *Faults in the Overall Appearance of Exhibitor and Horse include:*
  - a. *Loose, sloppy, dirty, or poor fitting clothing or hat; or loss of hat.*
  - b. *Over-cueing with reins and/or legs.*
  - c. *Poorly groomed, conditioned or trimmed horse; or poorly or ill fitted equipment.*
  - d. *Excessive staring at judge, head held crooked, or severe turning of the head.*
  - e. *Stiff, artificial or unnatural body, leg, arm, and/or head position.*
  - f. *Reins too long or short, or uneven.*
  - g. *Loose leg with open knee, or toes pointed down.*
  - h. *Shoulders held crooked or arms held in a straight, unbent position.*
  - i. *Exhibitor looking down to check leads or falling forward when stopping.*
  - j. *Poor position of the exhibitor in saddle, legs too forward or back.*
2. *Faults of the Performance include:*
  - a. *Wrong lead or break of gait for a few strides.*
  - b. *Oblong or flat sided circles, or horse dropping shoulder (counter arc) when circling.*
  - c. *Stopping rough, crooked, or dropping a hip out when stopping.*
  - d. *Backing sluggishly or crooked.*
  - e. *Failure to maintain a pivot foot or stepping behind with the front legs when turning, or failure to complete entire 90, 180, 270 or 360 degree turn.*
  - f. *Holding the head and/or neck excessively crooked when moving in straight lines or when stopping or backing.*
  - g. *Showing resistance when cued or reined.*
  - h. *Hesitation during any maneuver unless specified.*
  - i. *Failure of horse to stand still in pattern.*
  - j. *Pattern work or rough transitions.*
  - k. *Failure to exhibit change of speed when requested.*
3. *Severe Faults in the Overall Appearance of Exhibitor and Horse (avoids disqualification but should be placed below other exhibitors that do not incur a severe fault) include:*
  - a. *Touching horse.*
  - b. *Grabbing the saddle horn or any other part of the saddle.*
  - c. *Cueing with the end of the romal.*
  - d. *Spurring in front of the shoulder.*
4. *Severe Faults of the Performance (avoids disqualification but should be placed below other exhibitors that do not incur a severe fault) include:*
  - a. *Omission or addition of maneuvers.*
  - b. *Turning the wrong way.*
  - c. *Knocking over a cone or working on the wrong side of the cones.*
  - d. *Kicking at other horses, exhibitors or judge.*
  - e. *Severe disobedience or resistance by horse including,*

*but not limited to, rearing, bucking or pawing.*

5. *Disqualifications (should not be placed) include:*
  - a. *Failure by exhibitor to wear correct number in visible manner.*
  - b. *Willful abuse.*
  - c. *Excessive schooling or training.*
  - d. *Fall by horse or rider.*
  - e. *Illegal use of hands on reins.*
  - f. *Use of prohibited equipment*
- G. *Suggested Final Scoring shall be on a basis of 0-20, with an approximate breakdown as follows:*
  1. *Score of 20: Excellent equitation including body position and use of aids. Pattern is performed promptly, precisely and smoothly.*
  2. *Score of 18-19: Generally excellent performance with one minor fault in appearance and position of exhibitor or execution of the pattern (performance).*
  3. *Score of 16-17: Generally good pattern execution and equitation with one minor fault in precision or execution of pattern (performance) or appearance and position of exhibitor.*
  4. *Score of 14-15: Average pattern that lack quickness or precision, or rider has obvious equitation flaws that prevent effective horsemanship, or commits two or three minor faults in the performance or appearance and position of exhibitor.*
  5. *Score of 12-13: One major fault or several minor faults in the performance and/or appearance and position of exhibitor that precludes effective communication with the horse.*
  6. *Score of 10-11: Two major faults or many minor faults in the performance or appearance and position of exhibitor.*
  7. *Score of 6-9: Several major faults or one severe fault in the performance or appearance and position of exhibitor. Exhibitor demonstrates a complete lack of riding ability or commits a severe fault in the performance or appearance and position of exhibitor.*
  8. *Score of 1-5: Exhibitor commits one or more severe faults in the performance or appearance and position of exhibitor, but does complete the class and avoids disqualification.*

## **AM-120. AMATEUR BREAKAWAY ROPING**

This is a timed event with a two-minute time limit.

- A. **WESTERN ATTIRE.** See Rule SC-270.A. **Exception:** Safety helmet optional.
- B. **WESTERN TACK.** See Rule SC-270.B.
- C. This event shall be performed following the same general rules as youth calf roping.
- D. Horse must start from behind a barrier. A 10-second penalty will be added to the time for breaking the barrier. Calves or hornless cattle must be used.
- E. Two loops will be permitted. One or two ropes are to be tied to

the saddle horn by a heavy string, in such a manner as to allow rope to be released from the horn when the calf or hornless cattle reaches the end of the rope. A visible cloth or flag must be attached to the end of the rope tied to the horn to make it easier for the flagger to see it break free.

- F. Should the roper desire to use a second loop, he may either recoil if carrying only one rope or use a second rope tied to the saddle horn. If the second loop falls loose, it cannot be rebuilt.
- G. The contestant may free his first rope from the horn after a miss before getting his second loop ready if he wishes.
- H. The contestant shall receive no time should he break the rope from the horn by hand or touch the rope or string after the catch is made. If the rope dallies or will not break free when the calf reaches the end of it, the contestant will receive no time.
- I. Time will be called from drop of flag at barrier to the break of rope string from the saddle horn. A legal catch is to be any loop that goes completely over the head of the calf or hornless cattle's body, causing the rope to break away from the saddle horn. Roping the calf or hornless cattle without releasing the loop from the hand is not permitted.
- J. The contestant shall not attempt to rope the animal until the barrier flag has been dropped. Any attempt by a contestant to position his horse behind the barrier, enabling the contestant to rope the calf or hornless cattle without leaving the barrier or box, shall be considered a disqualification.
- K. Rope may not pass through bridle, tie-down, neck rope or any other device.
- L. A judge may, at his discretion, use the ring steward, other show officials or approved APHA judges to assist as barrier judges and to help determine legal catches or any rule infractions.
- M. It is recommended, whenever possible, the judge be on horseback and flag the class.

### AM-125. AMATEUR GOAT TYING

- A. **WESTERN ATTIRE.** See Rule SC-270.A. **Exception:**Safety helmet optional.
- B. **WESTERN TACK.** See Rule SC-270.B.
- C. **STARTING LINE.** The regular roping score line will be used as the starting line where arena conditions permit; if not used, the starting line would be at least fifteen (15) yards (13.71m) from the chutes.
  - 1. **Distance to Goat.** There is no set distance from the starting line to the goat but a minimum of fifty (50) yards (45.72m) is desirable. Arena conditions will govern this distance.
  - 2. **Goat Staked.** The goat should be tied to a stake with a rope at least ten (10) feet (3m) in length, the stake should be pounded completely into the ground so that no part of it is visible or above ground.
- D. **PROCEDURE.** The contestant must be mounted on a horse and must ride from the starting line to the goat, dismount from the horse, throw the goat by hand and tie any three legs togeth-

er with a leather string or piggin string, then stand clear of the goat.

1. **Goat Tie.** The goat's legs must be crossed and tied. The tie will be passed on by the field judge; if the tie is not secure for five seconds, the contestant will receive **no time**.
- E. **TIMING.** Timing will start when a contestant crosses the starting line and will stop when the completion of the tie is signaled.
  1. **Goat or Rope Run Over.** Should the contestant run over the goat or rope with his horse while mounted, he will be fined ten (10) seconds.
  2. **Goat Breaks Away.** If the goat breaks away because of the fault of the horse, the contestant will receive **no time**. If the goat should break away, it will be left to the judge's discretion whether or not a rerun will be permitted.

### AM-135. TEAM ROPING

- A. For rules governing this event see Rule SC-285., the Amateur being judged may be assisted by anyone, Amateur or non-Amateur.
- B. *Time Limit. For the horse being judged, there is a time limit of two minutes or two loops, whichever comes first.*

**FOR RULES TO OTHER APPROVED AMATEUR PERFORMANCE EVENTS NOT LISTED IN THIS SECTION, REFER TO THE CORRESPONDING OPEN EVENT IN THE SHOW & CONTEST SECTION OF THIS RULE BOOK.**

## AM-200. NOVICE AMATEUR DIVISION

- A. **INTERPRETATION OF RULES.** All rules pertaining to Amateur shall govern the Novice Amateur.

## AM-205. NOVICE AMATEUR ELIGIBILITY

- A. **QUALIFICATIONS.** Same as Amateur. See Rule AM-010. In addition:
1. **Point Limitation.** A Novice Amateur exhibitor **cannot have earned twenty (20) performance points** (Open, Amateur and/or Youth combined) in a class category, see Rule AM-250.A., in any recognized equine association in order to compete in novice classes in that category. The APHA reserves the right to check all equine associations/breed registries for points earned.
    - a. Once a Novice Amateur exhibitor has earned **fifty (50) Novice Amateur points** in a particular category, they will no longer be eligible to compete in Novice classes in that category in subsequent years.
  2. **Year Long Eligibility.** If an individual is considered a Novice upon application they will be considered a Novice for that calendar year. If an individual is considered a Novice on January 1, they may continue to show as a Novice for the calendar year, regardless of points earned.

## AM-210. NOVICE AMATEUR APPLICATION/RENEWAL

- A. **NOVICE AMATEUR EXHIBITOR CARD.** Every exhibitor competing in a Novice Amateur class must possess a current Amateur exhibitor card stating novice status and be in good standing with the APHA. **Show management must inspect the current card, photocopy of the current card, or a temporary card at each show.**
1. **Application/Renewal.** Application/renewal for a Novice Amateur card shall be made on a form provided by APHA, available from them at no charge, and returned with application fees as provided below. A temporary Novice card may be applied for through the show secretary at an APHA-approved show.
    - a. **Annual Fee.** There shall be an annual fifteen dollars (\$15.00) APHA charge for said card. (See front of rule book for fee charges.)
    - b. **Associated Fees.** Same as Amateur. See Rule AM-015.A.4-7.
  2. **Falsifying a Novice Amateur Application.** Will result in disciplinary action.
- B. **OWNERSHIP REQUIREMENTS.** Same as Amateur. See Rule AM-020.

## **AM-215. NOVICE AMATEUR TITLES AND AWARDS**

- A. **NOVICE AWARDS.** Novice Amateur awards are based solely on Novice Amateur points earned. ROM, Novice Amateur Honor Roll-Top 10, Novice Amateur Superior, Novice Amateur of the Year-Top 20, Zone Awards-Top 5.
1. **Points not Eligible for Amateur Awards.** Novice Amateur points may not be used for any of the Amateur Awards (ROM, Year-End, etc.) or show all-arounds.
- B. **FRAUDULENT CLAIMS OR ADVERTISING OF APHA TITLES OR AWARD.** The registration certificate of any horse may be revoked permanently by the Association if the owner thereof fraudulently advertises, claims or holds forth that this certain horse is entitled to a title or award prior to the title being officially awarded by the Association.

## **AM-220. APHA NOVICE AMATEUR SUPERIOR (EVENT) HORSE**

- A. See Rule AM-050.A.-D. for guidelines. See Rule SC-030 for method of tabulation and for points see Rule SC-060.

## **AM-225. APHA NOVICE AMATEUR HONOR ROLL AWARD**

- A. The Novice Amateur earning the most points in each novice amateur event during one calendar year will receive an appropriate award. Novice Amateurs and their horses placing second through tenth will receive an appropriate certificate. In order to be eligible for this award, a minimum of eight (8) points must be earned.

## **AM-230. APHA NOVICE/AMATEUR TOP TWENTY**

- A. Year end awards will be given to the twenty Novice Amateurs who earn the most points with one horse in novice performance classes. A contestant may exhibit more than one horse; however, the points earned by the Novice Amateur with each horse will be compiled separately. See Rule AM-060.
1. Points will be compiled on a one-horse, one-novice amateur basis in novice amateur events.
  2. Points are to be awarded on the same basis used in the open division (see Rule SC-060).
  3. Total novice amateur points will be compiled on Novice Amateur exhibitors from January 1 through December 31. Maximum of 20 APHA-approved shows, all under different judges, from which their total points will be tabulated. One alternate show will be used in case of a tie. The judge of this show will be different from the other show judges.
  4. Novice Amateurs must meet eligibility and ownership requirements (see Rule AM-010 and AM-020).

## **AM-235. APHA NOVICE AMATEUR REGISTER OF MERIT**

- A. See Rule AM-055.A.-E. for guidelines. See Rule SC-055 for method of tabulation.

### **AM-240. APHA NOVICE AMATEUR ZONE AWARD**

- A. This award would be to recognize the top five Novice /Amateurs living in each of the zones. This award is based on total cumulative points earned within their respective zones. (See Rule SC-105.B.3.f-g. for states listed in the respective zones.)
- B. Tiebreaker System:
1. Horse with greatest number of performance points.
  2. The most points earned in the fewest number of shows.

### **AM-245. GENERAL SHOW RULES**

- A. **MINIMUM CLASSES OFFERED.** If Novice Amateur classes are offered, a minimum of three Novice classes must be offered and the corresponding APHA Amateur classes must also be offered.
- B. **ORDER OF CLASSES.** The Novice Amateur class must be held prior to the corresponding Amateur class.
1. **Exhibit in Both Novice/Amateur.** Novice Amateurs may exhibit in the corresponding Amateur class.
- C. **JUDGING OF CLASSES.** Novice Amateur classes will be judged in accordance with the corresponding Amateur or Open rule for that particular event or contest.

### **AM-250. PERFORMANCE/EQUITATION CATEGORIES**

- A. **APPROVED CLASSES/CATEGORIES.** The following performance classes have been divided into twelve (12) categories and are approved for Novice Amateur Points and/or Awards.
1. **Category I**
    - a. Barrel Racing
    - b. Goat Tying
    - c. Pole Bending
    - d. Stake Race
  2. **Category II**
    - a. Western Riding
    - b. Reining
  3. **Category III**
    - a. Hunter Hack
    - b. Jumping
    - c. Working Hunter
  4. **Category IV**
    - a. Pleasure Driving
    - b. Utility Driving
  5. **Category V**

- a. Showmanship
- 6. **Category VI**
  - a. Breakaway Roping
  - b. Calf Roping
  - c. Heading
  - d. Heeling
  - e. Steer Stopping
- 7. **Category VII**
  - a. Western Pleasure
- 8. **Category VIII**
  - a. Hunter Under Saddle
- 9. **Category IX**
  - a. Horsemanship
- 10. **Category X**
  - a. Hunt Seat Equitation
- 11. **Category XI**
  - a. Trail
- 12. **Category XII**
  - a. Cutting
  - b. Working Cowhorse
  - c. Team Penning

**FOR RULES TO APPROVED NOVICE AMATEUR PERFORMANCE EVENTS NOT LISTED IN THE AMATEUR OR THIS SECTION, REFER TO THE CORRESPONDING OPEN EVENT IN THE SHOW & CONTEST SECTION OF THIS RULE BOOK. EXCEPTION: OPEN OR AMATEUR HALTER EVENTS ARE NOT APPROVED EVENTS FOR NOVICE AMATEURS.**

## YOUTH PROGRAM

### YP-000 YOUTH PROGRAM RULES AND REGULATIONS

The following Rules and Regulations shall become effective January 1 of the current year, and thereupon all Rules and Regulations and parts thereof-heretofore in force are hereby repealed.

#### YP-005. MEMBERSHIP

- A. **PRIVILEGES AND FEE.** Each AjPHA member in good standing, defined as a member currently free of disciplinary restrictions, shall be entitled to voting privileges. AjPHA memberships must be purchased under one individual's name. Membership fee (see fee schedule). See Rule GR-020.I.&J.
1. An annual membership (see fee schedule) consists of a 12-month period beginning with the month of purchase (based on postmark, postal meters not acceptable), and expiring the last day of the subsequent 12th month. (Example: If membership is postmarked February 20, it expires January 31 of the following year.)
  2. A J-Term membership (see fee schedule) begins with purchase and is valid through December 31st of the youth's 18-year-old year.

#### YP-010. YOUTH ELIGIBILITY

- A. **AGE.** The age limit for Youth Classes is eighteen (18) years of age. The minimum age of a youth exhibitor will be five (5) years of age with the exception of Leadline. For APHA purposes, the age of an individual on January 1 shall be maintained throughout the entire calendar year.
- B. **MARRIAGE.** Individuals, regardless of age, who are or have been married are ineligible to compete in Youth classes.
- C. **BIRTH CERTIFICATE.** A photocopy of the Youths birth certificate should be submitted to the APHA. Upon receipt of the birth certificate, the APHA will issue an identification card which expires when the Youth exceeds the age limit. The identification number found on the card should be given to show management for inclusion on the show results.
- D. **REMUNERATION.** A Youth may affect future Amateur eligibility by having shown, ridden, judged, trained or assisted in training a horse for remuneration, either directly or indirectly, or received compensation for instructing another person in riding in the previous five years prior to the date applying for an Amateur card. See Rule AM-010.

## YP-015. OWNERSHIP

- A. **ELIGIBILITY.** A horse exhibited in Youth classes does not have to be owned by the contestant showing the horse, however, in order to be eligible for the various APHA points, titles and awards and for exhibiting at shows sponsored by the APHA (i.e., World Show), the horse must be owned by the Youth and/or the youths family (mother, father, brother, sister, aunt, uncle, legal guardian or grandparent), family-owned corporation, ranch or farm. **Exception:** Leadline or Walk-Trot classes.
1. **Horses Under Lease.** Horses under lease to, but not owned by any of the above named persons, do not qualify for the APHA Youth points and/or awards.
  2. **Horses Owned In Partnership.** Horses owned in partnership or jointly with any person other than those listed above are not eligible for APHA Youth points or awards.
  3. **Horses Registered In The Name Of A Non-Family Owned Farm Or Ranch.** Horses registered in the name of a farm or ranch other than the youths family as listed above are not eligible for APHA Youth points or awards.
- B. **Evidence Of Ownership.** Ownership must be evidenced by the records of the APHA. Throughout these rules, the above shall stand as ownership requirements.
- C. **Transfer of Ownership.** The exhibitor must be able to prove ownership at the time of the show by presenting the APHA registration certificate or a legible photocopy with the correct owner or owner's name printed on the certificate by the APHA office.

## YP-020. APHA YOUTH TITLES/AWARDS REQUIREMENTS

- A. **APHA RESERVED YOUTH TITLES AND/OR AWARDS.** All APHA Youth Titles and Awards listed in the APHA Youth section of the APHA rule book are reserved by the APHA for its express use and will be awarded to the owner of record at the time the award is earned.
- B. **REGISTRATION REQUIREMENTS.** Titles will be awarded to any Youth/horse, which has been issued a registration certificate by the APHA, provided said Youth and horse meet the Title or Award requirements. See Rule SC-165.A.
- C. **ONE HORSE-ONE YOUTH.** Points toward all Titles and Awards will be tabulated on a **one horse-one youth basis.** In the event a horse is sold to any party other than specified in Rule YP-015., a new start **in acquiring points** must be made by the new owner.
- D. **OWNERSHIP/ELIGIBILITY REQUIREMENTS.** See Rules YP-010. and YP-015.
- E. **POINTS.** Points shall be awarded as outlined in Rule SC-060.A. **Exception.** Youth Showmanship at Halter and Youth Halter points shall be awarded to any mare or gelding registered, regardless of horse's age, (except weanlings) provided the Youth meets eligibility and ownership requirements of Rules YP-010 and YP-015.

- F. **APHA RECORD NOTATION.** Proper notation shall be made of all APHA Youth Titles and Awards issued in the records of the APHA.
- G. **FRAUDULENT CLAIMS OR ADVERTISING OF APHA TITLES OR POINTS.** The registration certificate of any horse may be revoked permanently by the Association if the owner thereof fraudulently advertises, claims or holds forth that this certain Youth/horse is entitled to a title or award prior to the title being officially awarded by the Association.

## **YP-025. PERFORMANCE CONTEST CATEGORIES**

- A. **CATEGORIES.** The following performance contests have been divided into six categories and are approved for points and/or awards.
1. Category I
    - a. Youth Barrel Racing
    - b. Youth Pole Bending
    - c. Youth Stake Race
    - d. Youth Goat Tying
    - e. Youth Team Penning
  2. Category II
    - a. Youth Reining
    - b. Youth Western Riding
    - c. Youth Working Cow Horse
    - d. Youth Trail
  3. Category III
    - a. Youth Working Hunter
    - b. Youth Hunter Hack
    - c. Youth Jumping
  4. Category IV
    - a. Youth Cutting
    - b. Youth Calf Roping
    - c. Youth Team Roping Heading
    - d. Youth Team Roping Heeling
    - e. Youth Steer Stopping
    - f. Youth Breakaway Roping
  5. Category V
    - a. Youth Hunter Under Saddle
    - b. Youth Western Pleasure
  6. Category VI
    - a. Youth Hunt Seat Equitation
    - b. Youth Showmanship
    - c. Youth Western Horsemanship
- B. **Breeding Stock Performance Categories.** The performance contests have been divided into six categories and are approved for points and/or awards for Breeding Stock horses as listed in YP-025. A. Exception: In Category VI, Breeding Stock Youth Showmanship, it may be divided into age groups (13 and under or 14 -18).

## YP-030. APHA SUPERIOR YOUTH CHAMPION AWARD

- A. **TITLE.** The title APHA Superior Youth Champion will be awarded to any Youth/horse combination which meet the qualifying Rules YP-010., YP-015. and YP-020. and these Title/Award requirements.
- B. **NO TIME LIMIT IN EARNING POINTS.** Points toward an APHA Superior Youth Championship need not be earned in any one year. They may be accumulated until the **youth** exhibitor reaches the eighteenth year age limit.
- C. **POINTS.** The Youth/horse combination have won a total of at least 270 points in recognized Youth halter and Youth performance classes in APHA approved "A" shows.
  - 1. **Halter.** At least 30 of those points have been won in Youth halter classes and of these 30 points a maximum of 15 points may be earned as a yearling.
  - 2. **Performance.** At least 240 of those points have been won in Youth performance classes.
  - 3. **Superiors.** Have earned a Superior in four (4) of the six (6) categories.
  - 4. **ROM.** Have earned a ROM in four of the six (6) categories in an event other than that in which the qualifying Superiors were won.
- D. **AWARD.** In the event that this title is awarded, an appropriate award shall be prepared and presented to the Youth exhibitor of the said horse at the next AjPHA Banquet of the American Junior Paint Horse Association.
- E. **RETROACTIVE.** This award shall be retroactive.

## YP-035. APHA YOUTH CHAMPION AWARD

- A. **TITLE.** The title APHA Youth Champion will be awarded to any Youth/horse combination which meet the qualifying Rules YP-010., YP-015. and YP-020. and these Title/Award requirements.
- B. **NO TIME LIMITS IN EARNING POINTS.** Points toward the APHA Youth Championship need not be earned in any one year. They may be accumulated until the **Youth** exhibitor reaches the eighteenth year age limit.
- C. **POINTS.** The Youth/horse combination must have earned a total of forty (40) or more points in youth competition in official shows recognized by the APHA provided:
  - 1. **Shows And Judges.** That the points have been won in five (5) or more youth shows or contests and under (5) or more judges.
  - 2. **Halter Points.** That at least sixteen (16) points have been won in youth halter classes and of these sixteen (16) points, a minimum of ten (10) points must be won in either A or B class shows. See Rules SC-055. and SC-060.A. Exception: Points shall be awarded to yearlings in their respective halter classes with a maximum of ten (10) halter points to qualify for a Championship.
  - 3. **Performance Points.** That at least sixteen (16) of these

points have been won in youth performance classes or contests, and with a minimum of five (5) points each having been earned in at least two (2) categories of youth performance events and cannot be earned in a combination of categories, as set forth in Rule YP-025.

**Note:** Only categories I through V will be used for tabulation of the sixteen (16) youth performance points for an APHA Youth Champion.

4. **Remaining Points Needed.** The remaining eight (8) points may be earned in any youth events listed in Rule YP-025. or Youth halter.
- D. **AWARD.** In the event the title of APHA Youth Champion is awarded, an appropriate award shall be prepared for the Youth exhibitor by the APHA office.

#### **YP-040. APHA YOUTH PERFORMANCE VERSATILITY AWARD**

- A. **TITLE.** The title APHA Youth Performance Versatility Award will be awarded to any Youth/horse which meet the qualifying Rules YP-010., YP-015. and YP-020. and these Title/Award requirements.
- B. **NO TIME LIMIT IN EARNING POINTS.** Points toward the APHA Youth Performance Versatility need not be earned in any one year. They may be accumulated until the **Youth** exhibitor reaches the eighteenth year age limit.
- C. **ROM.** To earn the title of APHA Youth Performance Versatility Award, five ROM's must have been earned in the performance events listed in Rule YP-090.B.C. One of these ROM's must have been earned in Showmanship at Halter.
- D. **SUPERIOR RATING.** A Superior rating must have been earned in one of these five events.
- E. **AWARD.** In the event the title of APHA Youth Performance Versatility is awarded, a certificate shall be prepared for the Youth exhibitor by the APHA office.

#### **YP-045. APHA YOUTH SUPERIOR EVENT AWARD**

- A. **TITLE.** The title of APHA Youth Superior Event will be awarded to any Youth/horse which meet the qualifying Rules YP-010., YP-015. and YP-020. and these Title/Award requirements.
- B. **NO TIME LIMIT IN EARNING POINTS.** Points toward an APHA Youth Superior Event need not be earned in any one year. They may be accumulated until the **Youth** reaches the eighteenth year age limit.
- C. **POINTS.** To earn the title of APHA Youth Superior Event, fifty (50) or more points must have been earned in one approved halter or performance event. See Rule YP-085.B.1. and YP-090.B.C. A Youth/horse combination may receive this title for each separate event in which it has earned at least fifty (50) points. See Rule SC-060.A.
- D. **CERTIFICATE.** When the title of APHA Youth Superior Event is awarded, a proper certificate shall be prepared for the

Youth exhibitor by the APHA office.

### **YP-050. APHA YOUTH REGISTER OF MERIT AWARD**

- A. **TITLE.** The title of APHA Youth Register of Merit will be awarded to any Youth and Youth/horse combination which meet the qualifying Rules YP-010., YP-015. and YP-020. and these Title/Award requirements.
- B. **NO TIME LIMIT IN EARNING POINTS.** Points toward an APHA Youth Register of Merit need not be earned in any one year. They may accumulate until the Youth reaches the eighteenth year age limit.
- C. **PURPOSE.** The purpose of the Register of Merit is to establish a record of excellence.
- D. **POINTS.** The Youth/horse combination are advanced to the Register of Merit when they have competed in one or more of the APHA-approved Youth contests shown in Rules YP-085.B.1. and YP-090.B.C. and have won at least ten (10) points in any one event as outlined in the scale of points for contests.
- E. **CERTIFICATE.** When the title of Youth Register of Merit is awarded, a proper certificate shall be prepared for the Youth exhibitor by the APHA office.

### **YEAR-END AWARDS**

#### **YP-055. APHA YOUTH TOP TWENTY AWARD**

- A. **TITLE.** The title of APHA Youth Top Twenty will be awarded to any Youth/horse combination which meet the qualifying Rules YP-010., YP-015., and YP-020. and these Title/Award requirements.
- B. **YEAR-END AWARDS.** Year-end awards will be given to the twenty Youth who earn the most points with one horse in Youth activity halter and performance classes. A contestant may exhibit more than one horse, however, the points earned by the Youth with each horse will be compiled separately.
  - 1. **Time Period.** Total Youth points will be compiled on Youth exhibitors from January 1 through December 31 of each year.
  - 2. **Points.** Points will be awarded on the same basis used in the Open division. See Rule SC-060.
  - 3. **Maximum Number Of Shows And Judges.** A maximum of 20 APHA-approved shows, all under different judges, **may be used** from which their total points will be tabulated.
  - 4. **Tie Breaker System.**
    - a. One alternate show will be used in case of a tie.
    - b. The judge of this show will be different from the other show judges.
- C. **Award.** When the title of APHA Top Twenty are awarded, buckles shall be prepared and presented to the Youth in each age group by the APHA office.

## YP-060. APHA YOUTH HONOR ROLL AWARD

- A. **TITLE.** The title of APHA Youth Honor Roll will be awarded to any Youth/horse combination which meet the qualifying Rules YP-010., YP-015., and YP-020. and these Title/Award requirements.
- B. **ELIGIBILITY.** In order to be eligible for this award, a minimum of six (6) points must be earned and a copy of the youths birth certificate must be on file in the APHA office.
- C. **AWARD.** The Youth in each age group earning the most points in each youth event during one calendar year will receive an appropriate award. See Rules YP-085.B.1. and YP-090.B&.C.
- D. **CERTIFICATE.** Youth and their horses placing second through tenth will receive an appropriate certificate.

## YP-065. APHA YOUTH ZONE AWARD

- A. **TITLE.** The title of APHA Youth Zone will be awarded to any Youth/horse combination which meet the qualifying Rules YP-010., YP-015. and YP-020. and these Title/Award requirements.
- B. **POINTS.** This award recognizes the top five (5) Youth living in each of the Zones found on the APHA Zone Map. This award is based on total cumulative points earned within their respective zone from January 1 through December 31 of each year. See rule SC-105.B.3.f. for states listed in the respective zones.
- C. **TIEBREAKER SYSTEM.**
  - 1. Youth/horse with the greatest number of performance points.
  - 2. The most points earned in the fewest number of shows.
- D. **AWARD.** The five youth and their horses in each age group in their respective zone will be recognized and receive an appropriate award.

## YP-070. CLASS AND SHOW APPROVAL

- A. **CLASSES.** The APHA strongly recommends that show management provide classes for Youth at all APHA approved shows.
- B. **SPONSORS.** See Rule SC-090.A. for eligible sponsors.
- C. **CLASSIFICATION OF SHOW.** Entries in Youth Activity classes will count toward classification of any APHA approved show.
- D. **YOUTH OR YOUTH/AMATEUR SHOWS.** All Youth and/or Youth/Amateur shows may be held separately from the independent APHA Open shows, and the APHA reserves the right to approve only one show per calendar year when sponsored by the same organization or show management.
- E. **MULTI-JUDGED SHOWS.** Each *regional club* in the United States, Canada, or an *international* country is eligible for one set of all Youth or one set of combined Youth/Amateur multi-judged shows per year. (See Rule SC-105.A.& B.)
- F. **APPROVAL/APPLICATIONS.** See Rule SC-090.A-N. for Youth Show approvals and applications.

- G. **RESULTS.** See Rules SC-125.A-F. for Youth show Results.
- H. **JUDGES.** See Rules JU-000.A-K. for rules concerning judges.

### YP-075. YOUTH AGE DIVISIONS

- A. **RECOGNIZED DIVISIONS.** The APHA recognizes the following age divisions for Youth. Any exceptions will be specified in the appropriate event.
1. **If One Class Is Offered.** If one class is offered it should be held for eighteen (18) years and younger.
  2. **If Two Classes Are Offered.** If two classes are offered it should be for thirteen (13) years and younger and fourteen (14) through eighteen (18) years. See SC-185.D.
  3. If Breeding Stock Performance Category Classes are offered. One class should be offered and held for eighteen (18) years and younger. Exception: Breeding Stock Youth Showmanship, it may be divided into age groups (13 and under or 14 - 18.)
- B. **SPLITTING OR COMBINING AGE DIVISIONS.** Show management may combine or split age groups as justified by entries if there is unanimous consent of all involved exhibitors, however, if one division is not a point earning class, then show management may combine age groups, without unanimous consent of all exhibitors in order to make the division a point earning class. Exception: Excluding Breeding Stock Performance Category Classes except for Breeding Stock Youth Showmanship.

### YP-080. YOUTH PROGRAM GENERAL RULES

- A. **HORSE PROPERLY REGISTERED.** Any Youth exhibitor must be able to prove that the horse is properly registered with the American Paint Horse Association. See Rule SC-165. Show management must inspect the **original** Registration certificate or photocopy of certificate for each horse entered in approved classes.
1. **Photocopy.** If a photostatic copy is used, it must be made for the type of certificate which lists ownership with breeding information on the face of the certificate.
- B. **STALLIONS. STALLIONS CANNOT BE USED IN ANY APHA-APPROVED YOUTH CLASSES.**
- C. **ENTRY AND OWNERSHIP.** Entry shall be made in the name of the contestant and the entry must be signed by the parent or legal guardian of the exhibitor. If the exhibitor and owner is the same, that same name must be listed on the show result sheets as it appears on the Registration Certificate. For show entry fees see Rule SC-160.E.
- D. **ENTRY WITHDRAWAL.** See Rules SC-175.A. and SC-185.A.
- E. **ERRORS IN ENTRY.** The exhibitor is responsible for errors on the entry blanks. A horse entered in the wrong class may be transferred to its correct class after the judging program has been printed.

- F. **CONTESTANTS EXHIBITING THE SAME HORSE.** A horse may not be shown by more than one contestant in the same event or compete in the same event regardless of the Youth age divisions. **Example:** A horse being exhibited in Western Pleasure, 13 & under, may not be exhibited in Western Pleasure, 14 to 18, by another exhibitor at the same horse show.
- G. **RIDING TWO HORSES.** An exhibitor may exhibit a maximum of two horses in the following individual working events: barrel racing, breakaway roping, calf roping, cutting, team penning, goat tying, jumping, pole bending, reining, stake race, steer stopping, team roping heading, team roping heeling, trail, Western riding, working cowhorse and working hunter. Each horse may have only one rider per class.
- H. **REQUEST BY JUDGE TO CHANGE HORSES.** A judge may **not** ask the exhibitor to change horses with another exhibitor in any Youth event.
- I. **EXHIBITOR SECURED TO SADDLE.** Youth exhibitors may not be tied, buckled or fastened to a horse or any portion of the tack in Youth classes. **EXCEPTION:** Any person with a handicap which necessitates such assistance.
- J. **UNASSISTED ENTRY INTO ARENA.** All horses in Youth events, with the exception of lead-line and walk-trot classes, must enter the arena unassisted.
- K. **TIMED EVENTS.** In all timed events, the horse must enter the arena unassisted. The exhibitor may enter the opening of the arena at the exhibitors' preferred speed. The gate will close once the horse is in the arena. The gate must remain closed and the horse come to a halt inside the arena before the gate is again opened.

*1. A five (5) second penalty will be assessed if the hat or helmet is not on the exhibitor's person for the entire time the exhibitor is in the arena in youth barrel racing, youth pole bending, or youth stake race.*

- L. **SITUATIONS/EVENTS NOT SPECIFICALLY STATED.** FOR ANY SITUATION OR EVENT NOT COVERED BY YOUTH PROGRAM RULES AND REGULATIONS, THE RULES AND REGULATIONS APPLYING TO APHA APPROVED SHOW AND CONTESTS SHALL APPLY.

**EXAMPLES:**

- 1. **UNSPORTSMANLIKE CONDUCT.** See Rule GR-040.G. and GR-066.
- 2. **GO-ROUNDS.** See Rule SC-185.J.
- 3. **HACKAMORE/SNAFFLE.** See Rule SC-240.D.E

**YP-085. HALTER**

- A. **POINTS.** See Rule SC-060. for distribution of points.
- B. **APPROVED CLASSES.** Individual Halter Classes for mares and geldings are approved for Youth shows and points. Classes must be limited to horses of one sex. (See Rule SC-175.F.)
  - 1. **INDIVIDUAL CLASSES.**
    - a. Mares (All Ages).
    - b. Geldings (All Ages).
  - 2. Classes May Be Separated Into:

- a. Junior Mares (Age 3 and Under).
  - b. Senior Mares (Age 4 and Over).
  - c. Junior Geldings (Age 3 and Under).
  - d. Senior Geldings (Age 4 and Over).
3. Separate age classes for Mares and Geldings.
- a. Yearlings
  - b. Two-Year-Olds
  - c. Three-Year-Olds
  - d. Four-Year-Olds and Over
- C. **GELDINGS LISTED AS STALLIONS.** Geldings which are still listed as stallions according to APHA records at the time the show results are processed at the APHA office will be disqualified.

## **YP-090. PERFORMANCE AND EQUITATION EVENTS**

- A. **POINTS.** See Rule SC-060. for point distribution.
- B. **APPROVED PERFORMANCE EVENTS.**
- 1. Barrel Racing.
  - 2. Breakaway Roping.
  - 3. Calf Roping.
  - 4. Cutting.
  - 5. Goat Tying.
  - 6. Hunter Hack.
  - 7. Hunter Under Saddle (BPH).
  - 8. Jumping.
  - 9. Pole Bending.
  - 10. Reining.
  - 11. Showmanship at Halter.
  - 12. Stake Race.
  - 13. Steer Stopping.
  - 14. Team Penning.
  - 15. Team Roping Heading.
  - 16. Team Roping Heeling.
  - 17. Trail.
  - 18. Western Pleasure.
  - 19. Western Riding.
  - 20. Working Cowhorse.
  - 21. Working Hunter.
- C. **EQUITATION EVENTS.**
- 1. Hunt Seat Equitation.
  - 2. Western Horsemanship (Equitation).
- D. **EQUITATION PARTICIPATION EVENTS.**
- 1. Lead Line.
  - 2. Walk Trot.
- E. **BREEDING STOCK PERFORMANCE EVENTS.**
- 1. Barrel Racing.
  - 2. Breakaway Roping.
  - 3. Calf Roping.
  - 4. Cutting.
  - 5. Goat Tying.
  - 6. Hunter Hack.
  - 7. Hunter Under Saddle (BPH).
  - 8. Jumping.

- 9 Pole Bending.
10. Reining.
11. Showmanship at Halter.
12. Stake Race.
13. Steer Stopping.
14. Team Penning.
15. Team Roping Heading.
16. Team Roping Heeling.
17. Trail.
18. Western Pleasure.
19. Western Riding.
20. Working Cowhorse.
21. Working Hunter.

**F. BREEDING STOCK EQUITATION EVENTS.**

1. Hunt Seat Equitation.
2. Western Horsemanship (Equitation).

**FOR RULES TO ALL OTHER APPROVED YOUTH CLASSES NOT FOUND IN THIS YOUTH SECTION, REFER TO THE CORRESPONDING OPEN EVENT IN THE OPEN SHOW AND CONTEST SECTION OF THIS RULE BOOK.**

**YP-095. ALL-AROUND YOUTH APPROVED SHOW AWARD**

- A. **AWARD NOT MANDATORY.** It is not mandatory for an all-around youth award to be made at an APHA approved show; however, if such an award is offered, it must be based on a **one-horse, one rider** combination.
- B. **ELIGIBILITY.** All approved Youth classes, including halter, will count equally towards this award **but** in order to be eligible to receive this award, the contestant must show in at least three Youth performance classes. No particular class may be considered mandatory.
- C. **POINTS.** Points will be compiled as set forth in Rule SC-145.A.2-4.

**YP-100. SHOWMANSHIP AT HALTER**

- A. **ATTIRE.**
  1. Suitable western attire should be worn as outlined by Rule SC-235.A. Exception: Spurs, chinks, or chaps must not be worn.
  2. A clean well fitting halter with an appropriate lead is required.
- B. **CLASS DESCRIPTION.**
  1. The showmanship class is not another halter class and should not be judged as such. The class shall be judged strictly on the exhibitor's ability to fit and show a horse at halter. The horse is merely a prop to demonstrate the ability and preparation of the exhibitor. The ideal showmanship performance consists of a poised, confident neatly attired exhibitor leading a well conditioned and groomed horse that performs the requested pattern with smoothness,

willingness and precision.

2. A pattern shall be posted with sufficient time for exhibitors to review prior to the commencement of their class. If there is a finals pattern, it also shall be posted at the same time.

### **C. CLASS PROCEDURES.**

1. The judge may ask exhibitors to enter the ring and then work individual or work their patterns starting from the gate.
2. The following maneuvers are considered acceptable:
  - a. Lead the horse at a walk and trot.
  - b. Stops.
  - c. Turns of 90 (1/4), 180 (1/2), 270 (3/4), 360 (full turn) degrees or any combination or multiple of these turns.
  - d. Back in a straight or curved line.
3. The judge must have each exhibitor set the horse up squarely for inspection during the class.
4. Horses may be lined up side by side or head to tail.

### **D. JUDGING POINTS.**

1. Appearance of the exhibitor should be neat, clean and appropriate western wear must be worn.
2. Appearance of Horse: The horse should appear fit and well conditioned. The hair coat should be clean and well brushed. The mane and tail should be clean and tangle free. The mane may be banded or braided, but it is not mandatory. It is acceptable to roach the mane but the forelock and tuft over the withers should be left. The bridle path, eyebrows and long hairs on the head and legs should be clipped, except where government regulations prohibit. The inside of the ears may be clipped. Hooves should be properly trimmed and if shod, the shoes should fit correctly and clinches should be neat. Hooves should be clean and may be painted black, brown or clear, with hoof dressing, or be shown naturally. Tack should fit properly and be neat, clean and in good repair.
3. Performance.
  - a. Exhibitors should be poised, confident, courteous and sportsmanlike at all times. The exhibitor should continue showing the horse, correcting faults in the positioning of the horse until the class has been placed or excused.
  - b. The exhibitor must lead on the horse's left side holding the lead shank in the right hand near the halter with the tail of the lead held in the left hand. Exhibitor should not hold on to the chain portion of the lead shank. The excess lead should never be tightly coiled or drag the ground, but should be folded loosely coiled. The exhibitor should maintain this hand positioning for the entire class unless requested by the judge to show the horse's teeth. Leading, backing, turning and initiating the set up should be performed from the left side of the horse. The exhibitor should never stand directly in front of their horse.
  - c. The stop should be straight, smooth and responsive

- with the horse's body remaining straight.
- d. The exhibitor should face the horse when backing. The horse should back up readily with the head, neck and body aligned in a straight or curved line as instructed.
  - e. When executing a turn to the right the exhibitor should face the horse and move the horse away from them. On turns of less than 90 degrees it is acceptable to lead the horse toward them. On turns of 90 degrees or greater the horse should pivot on the right or left hind leg while stepping across with the front legs.
  - f. The horse should set up quickly with the hooves squarely underneath the body. The exhibitor does not have to reset a horse that stops square. The exhibitor should stand angled toward the horse, use only the lead shank to achieve the set up and never leave the horse's head. The exhibitor should never stand directly in front of their horse, touch the horse with their hands or feet, or visibly cue the horse by pointing their feet at the horse's hooves during set up. It is recommended, but not mandatory, that exhibitors use the "Quarter Method" when presenting their horse. The exhibitor should maintain a position that is safe for themselves and the judge. The position of the exhibitor should not obstruct the judge's view of the horse and allow the exhibitor to maintain awareness of the judge's position at all times. The exhibitor should not crowd other exhibitors when lining up. When moving around the horse the exhibitor should change sides in front of the horse and assume the same position on the right side of the horse that they had on the left side.
4. Faults.
- a. Minor Faults. Poorly groomed, conditioned or trimmed horse. Dirty, ragged or ill-fitting halter or lead. Improper position by the exhibitor. Excessively stiff, artificial or unnatural movement around the horse or when leading. Excessive use of verbal cues. Continuous holding of the chain portion of the lead. Lead shank tightly coiled around hand or dragging the ground. Taking hands off of lead or changing hands on the lead, except when showing the horse's teeth. Drifting of the horse when led. Horse stops crooked or drops a hip out when stopping, setting up or standing. Leading, backing, or turning sluggishly or crooked. Horse not set up squarely or excessive time is required to set up. Failure to maintain a pivot foot during turns. Failure to perform maneuvers at designated markers, but horse is on pattern.
  - b. Major Faults. (Avoids disqualification but should not place above exhibitors that do not incur a major fault.) Complete failure to move around horse by the exhibitor and obstructing the judge's view. Exhibitor touching the horse or kicking or pointing their feet at the horse's hooves during set up. Standing directly in front of the horse. Omission or addition of maneuvers. Knocking

- over a cone. Working on wrong side of cones.
5. **Disqualifications.** (Must not be placed.) Horse escapes from exhibitor. Failure of exhibitor to wear correct number in a visible manner. Any physical abuse of the horse. Excessive schooling or training. Improper attire. Loss of control or severe disobedience that endangers others to include but not limited to: biting, pawing, rearing, kicking out or continuously circling the exhibitor. Leading on the wrong side of the horse.

#### **YP-101. BREEDING STOCK YOUTH SHOWMANSHIP AT HALTER**

- A. See Rule YP-100 for rules governing this event.

#### **YP-105. LEAD LINE (EQUITATION)**

- A. **ATTIRE.** Youth may exhibit in Western or English attire. Equipment on the horse must correspond with exhibitor attire, including a saddle adjusted so that the exhibitor's feet are placed properly in stirrups. See rules SC-235 or SC-240. and SC-195 or SC-200.
- B. **AGE.** This class is for Youth three to eight years of age as of January 1. The horse must be led by an adult eighteen years of age or older, and the contestant must exhibit some knowledge of equitation.
  1. **May Not Show in Other Classes.** The contestant in a lead line class may not show in other riding classes at that show, but the horse can be used in other classes.
- C. **NO POINTS.** This class will not count for APHA Youth points or toward all around awards, but **will count as entries in the show.**
- D. **OWNERSHIP.** It is not necessary that the horse be in the rider's name.
- E. **RING PROCEDURE.** The exhibitors will enter the ring with feet properly placed in stirrups at a flat-footed walk turning to the right and proceeding in a counter clockwise direction on the rail. The class will be worked at a walk or trot both directions of the ring.
  1. **Backing the Horse.** In the lineup, the judge may ask riders to back their horses to help him judge the extent of the rider's horsemanship. If the judge asks the rider to back the horse in the lineup, the adult should not aid the rider. The adult should only keep the horse under control.
  2. **Lead Shank.** A lead shank at least six feet long must be attached to the shank of the bit or to a halter that is under the bridle so that while the rider is in the ring, the horse is controlled by the adult.
- F. **JUDGING THE RIDER.** The rider will be judged on his basic position in the saddle, hand, leg, feet in stirrups, seat and back position.
- G. **SHOW RESULTS.** The lead line show results will be sent with the other results by the show secretary and upon recordation in the APHA office, a certificate will be mailed to those

Youth who have participated in a minimum of ten (10) classes and have sent written request for such certificate.

### YP-110. WALK TROT DIVISION

- A. **ATTIRE AND TACK.** Attire and tack must meet the standards in Rules SC-235 and SC-240, SC-195.A. and SC-200.A.
- B. **AGE.** This division is for Youth *five (5) to nine (9)* years of age and younger. When an exhibitor enters any of these walk trot classes at a show, he or she may not enter any other classes at that show with the exception of halter and showmanship.
1. **Class Limit.** Exhibitors may compete in only one showmanship class, walk trot or 13 and under, but not both.
  2. **Limited Classes.** An exhibitor may not show in both lead line and walk trot riding classes. The horse can be used in other classes.
- C. **OWNERSHIP.** The horse need not be in the rider's name.
- D. **NO POINTS.** These classes will not count for APHA Youth points or toward all-around awards, but will count as entries in the show.
- E. **CLASSES WHICH MAY BE OFFERED.**
1. **Showmanship.** To be judged in the same manner as any other showmanship class.
  2. **Western Pleasure.** To be judged in the same manner as any other western pleasure class but omitting the lope.
  3. **Western Horsemanship.** To be judged with a simple pattern but omitting the lope. Will not be asked to mount or dismount.
  4. **Trail.** Scored the same as any other trail class but omitting the lope. Will not be asked to ground tie. A minimum of four and a maximum of six obstacles is required.
  5. **Hunter Under Saddle.** To be judged the same as any other hunter under saddle class, but omitting the canter or hand gallop.
  6. **Hunt Seat Equitation.** To be judged with a simple pattern but omitting the canter. Will not be asked to drop irons, mount or dismount.
  7. **Working Hunter Over Fences.** Scored on suitability of horse to rider, manners and style of jumping. Obstacles will not exceed **one foot**, crossbars are preferred. One change of direction, simple course of no more than eight (8) fences or no less than four (4) fences. No cantering. However, cantering after fence is acceptable as long as horse returns to a trot before next fence.
- F. **SHOW RESULTS.** The walk trot show results will be sent with the other show results by the show secretary and upon recordation in the APHA office, a certificate will be mailed to those Youth who have participated in a minimum of fifty (50) classes and have sent written request for such certificate.

### YP-115. HUNT SEAT EQUITATION

- A. **ENGLISH APPOINTMENTS**
1. **English Attire.** See Rule SC-195.A. **Exception:** Helmet

with harness properly attached under the chin is required for all youth participating in any warm up/schooling area or class involving jumps, excluding trail. See equipment and attire chart in back of rule book.

2. **English Tack.** See Rule SC-200.A.

- B. *Equitation. Hunt seat equitation on the flat is an evaluation based on the ability of a rider to perform various maneuvers in harmony with his/her horse. The communication between horse and rider through subtle cues and aids should not be obvious. Equitation is judged on the rider and his/her effect on the horse. Hunt seat equitation on the flat provides a base for a natural progression to over fence classes.*
- C. *Pattern. It is mandatory that the judge post the pattern at least one hour prior to commencement of the class. The pattern should be designed so the majority of exhibitors can perform it in a reasonable length of time (under 60 seconds). All patterns must include a trot and canter. Horses' gaits are to be ridden with the same cadence and speed as you would find in the rail phase. All ties will be broken at the discretion of the judge. Failure to complete the pattern will not be a disqualification, but shall be scored accordingly.*
- D. *Class Procedure. Exhibitors may be worked individually from the gate or they may all enter at once but a working order must be drawn regardless. The entire class, or only the finalists, may work at all three gaits at least one direction of the arena. Rail work can be used to break ties and possibly adjust placings. Individual works may be comprised of any of the following:*
1. *Group #1: Walk, sitting Trot, Extended Trot, Posting Trot, Canter, Circles, Figure 8, Halt, Back, Sidepass, Address Reins, Demonstrate Change of diagonal.*
  2. *Group #2: Serpentine (Trot or Canter, Turn on Haunches or Forehand, Leg Yield, Flying or Simple Change of Lead.*
  3. *Group #3: Canter and Hand Gallop in a straight or curved line, Counter Canter Figure 8, Drop or Pick-up irons without stopping, Dismount and Mount.*
    - a. *A turn on the forehand to the right is accomplished by moving haunches to the left.*
    - b. *A forehand turn to the left is accomplished by moving haunches to the right.*
    - c. *If riders are asked to drop their irons, they can leave them down or cross them over the withers.*
- E. *Basic Position.*
1. *To mount, take up reins in left hand and place hand on withers. Grasp stirrup leather with right hand and insert left foot in stirrup and mount. To dismount, rider may either step down or slide down. The size of rider must be taken into consideration.*
  2. *Hands should be over and in front of horse's withers, knuckles thirty degrees inside the vertical, hands slightly apart and making a straight line from horse's mouth to rider's elbow. Method of holding reins is optional, and bight of reins may fall on either side. However, all reins must be picked up at the same time.*
  3. *The eyes should be up and shoulders back. Toes should be at*

*an angle best suited to rider's conformation; heels down, calf of leg in contact with horse. Iron should be on the ball of the foot and must not be tied to the girth.*

- F. *The Walk. Should be a 4-beat gait with the rider in a vertical position with a following hand.*
- G. *The Posting Trot. Figure 8 at trot, demonstrating change of diagonals. At left diagonal, rider should be sitting the saddle when left front leg is on the ground; at right diagonal rider should be sitting the saddle when right front leg is on the ground; when circling clockwise at a trot, rider should be on left diagonal; when circling counter-clockwise, rider should be on right diagonal. The rider should close his/her hip angle to allow his/her torso to follow the horizontal motion of the horse. The upper body should be inclined about 20 degrees in front of the vertical.*
- H. *Sitting Trot and Canter. At the sitting trot the upper body is only slightly in front of the vertical. At the center the body should be positioned slightly more in front of the vertical. As the stride is shortened, the body should be in a slightly more erect position.*
- I. *Two Point Position. The pelvis should be forward, but relaxed, lifting the rider's weight off the horse's back and transferring the weight through the rider's legs. In this position the two points of contact between horse and rider are the rider's legs. Hands should be forward, up the neck, not resting on the neck.*
- J. *Hand Gallop. A three-beat, lengthened canter ridden in two-point position. The legs are on the horse's sides while the seat is held out of the saddle. When at the hand gallop, the rider's angulation will vary somewhat as the horse's stride is shortened and lengthened. A good standard at a normal hand gallop should be about 30 degrees in front of the vertical.*
- K. *Suggested Scoring. Scoring may be on a basis of 0-20 with 1/2-point increments acceptable, an approximate breakdown follows:*
  - 1. *Score of 20: Excellent equitation including body position and use of aids. Pattern is performed promptly, precisely and smoothly.*
  - 2. *Score of 18-19: Generally excellent performance with one minor fault in appearance and position of exhibitor or execution of the pattern (performance.)*
  - 3. *Score of 16-17: Generally good pattern execution and equitation with one minor fault in precision or execution of pattern (performance) or appearance and position of exhibitor.*
  - 4. *Score of 14-15: Average pattern that lacks quickness or precision, or rider has obvious equitation flaws that prevent effective equitation, or commits two or three minor faults in the performance or appearance and position of exhibitor.*
  - 5. *Score of 12-13: One major fault or several minor faults in the performance or appearance and position of exhibitor that precludes effective communication with the horse.*
  - 6. *Score of 10-11: Two major faults or many minor faults in the performance or appearance and position of exhibitor.*
  - 7. *Score of 6-9: Several major faults or one severe fault in the performance or appearance and position of exhibitor.*

*Exhibitor demonstrates a complete lack of riding ability or commits a severe fault in the performance or appearance and position of exhibitor.*

8. *Score of 1-5: Exhibitor commits one or more severe faults in the performance or appearance and position of exhibitor, but does complete the class and avoids disqualification.*

## **YP-120. WESTERN HORSEMANSHIP(EQUITATION)**

- A. **WESTERN ATTIRE.** See Rule SC-235.

**Exception:** Safety helmet optional.

- B. **WESTERN TACK.** See Rule SC-240.

**Exception:** Leg wraps and/or boots optional at rider's discretion.

- C. *Equitation.*

1. *The western horsemanship class is designed to evaluate the rider's ability to execute, in concert with their horse, a set of maneuvers prescribed by the judge with precision and smoothness while exhibiting poise and confidence, and maintaining a balanced, functional, and fundamentally correct body position. The ideal horsemanship pattern is extremely precise with the rider and horse working in complete unison, executing each maneuver with subtle aids and cues.*
2. *It is mandatory that the judge post any pattern (s) to be worked at least one hour prior to the commencement of the class; however, if the judge requires additional work of exhibitors for consideration of final placing, the pattern may be posted. Pattern(s) should be designed to test the horseman's ability. All ties will be broken at the judge's discretion.*

- D. *Class Procedures. All exhibitors must enter the ring and then work individually or each exhibitor may be worked from the gate individually. When exhibitors are worked individually from the gate, a working order is required. Exhibitors should be instructed to either leave the arena, fall into line, or fall into place on the rail after their work. The whole class, or just the finalists, may work at all three gaits at least one direction of the arena.*

1. *The following maneuvers are acceptable in a pattern: walk, jog, trot, extended trot, lope, or extended lope in a straight line, curved line, serpentine, circle, or figure 8, or combination of these gaits and maneuvers; stop; back in a straight or curved line; turn or pivot, including spins and rollbacks on the haunches and/or on the forehand; side pass, two track, or leg yield; flying or simple change of lead; counter canter; or any other maneuver; or ride without stirrups. A back should be asked for at sometime during the class. Judges should not ask the exhibitors to mount or dismount.*
2. *Suggested Scoring. Scoring may be on a basis of 0 to 20 with 1/2 point increments acceptable. Ten points should be*

allocated toward overall appearance of exhibitor and horse and 10 points allocated toward performance of the pattern.

3. *Overall Appearance of Exhibitor and Horse (10 points): The exhibitor's overall poise, confidence, appearance, and position throughout the class as well as the physical appearance of the horse will be evaluated.*
  - a. *Appearance and Position of Exhibitor. Appropriate western attire must be worn. Clothes and person are to be neat and clean.*
  - b. *Position of Exhibitor. The exhibitor should appear natural in the seat and ride with a balanced, functional, and correct position regardless of the maneuver or gait being performed. During the railwork and pattern the exhibitor should have strong, secure, and proper position. Exhibitors should sit and maintain an upright position with the upper body at all gaits. The rider should sit in the center of the saddle and the horse's back with the legs hanging to form a straight line from the ear, through the center of the shoulder and hip, touching the back of the heel or through the ankle. The heels should be lower than the toes, with a slight bend in the knee and the lower leg should be directly under the knee.*
    1. *The rider's back should be flat, relaxed and supple. An overly stiff and/or overly arched lower back will be penalized. The shoulders should be back, level and square. The rider's base of support should maintain secure contact with the saddle from the seat to the inner thigh. Light contact should be maintained with the saddle and horse from the knee to mid-calf. The knee should point forward and remain closed with no space between the exhibitor's knee and the saddle. The exhibitor will be penalized for positioning the legs excessively behind or forward of the vertical position. Regardless of the type of stirrup, the feet may be placed home in the stirrup, with the boot heel touching the stirrup, or may be placed with the ball of the foot in the center of the stirrup. The rider's toes should be pointing straight ahead or slightly turned out with the ankles straight or slightly broken in. Riding with toes only in the stirrup will be penalized. Those exhibitors that can maintain the proper position throughout all maneuvers should receive more credit. When riding without stirrups, the exhibitor should maintain the same position as previously described.*
    2. *Both hands and arms should be held in a relaxed, easy manner, with the upper arm in a straight line with the body. The arm holding the reins should be bent at the elbow forming a line from the elbow to the horse's mouth. The free hand and arm may be carried bent at the elbow in a similar position as*

*the hand holding the reins or straight down at the rider's side. Excessive pumping of the free arm as well as excessive stiffness will be penalized. The rider's wrist is to be kept straight and relaxed, with the hand held at about 30 to 45 degrees inside the vertical. The rein hand should be carried immediately above or slightly in front of the saddle horn. The reins should be adjusted so that the rider has light contact with the horse's mouth, and at no time shall reins require more than a slight hand movement to control the horse. Excessively tight or loose reins will be penalized.*

- 3. The rider's head should be held with the chin level and the eyes forward, and may be directed slightly toward the direction of travel. Excessive turning of the head to the inside of the circle, or down at the horse's head or shoulder will be penalized.*
- 4. The exhibitor should not crowd the exhibitor next to or in front of them when working on the rail and should pass to the inside of the arena. When reversing on the rail, the exhibitor should always reverse to the inside of the arena.*

*E. Appearance of Horse. The horse's body condition and overall health and fitness should be assessed. The horse should appear fit and carry weight appropriate for the body size. A horse which appears sullen, dull, lethargic, emaciated, drawn, or overly tired should be penalized according to severity. Tack should fit the horse properly and be neat, clean and in good repair.*

*F. Performance (10 Points). The exhibitor should perform the work accurately, precisely, smoothly, and with a reasonable amount of promptness. Increasing speed of the maneuvers performed increases the degree of difficulty, however, accuracy and precision should not be sacrificed for speed. Exhibitors that perform the pattern sluggishly and allow their horse to move without adequate impulsion, collection, or cadence will be penalized. The horse should perform all maneuvers in the pattern willingly, briskly, and readily with minimal visible or audible cueing.*

- 1. Failure to follow the prescribed pattern, knocking over or working on the wrong side of the cones, or severe disobedience will not result in a disqualification, but should be severely penalized and the exhibitor should not place above an exhibitor that completes the pattern correctly.*
- 2. Excessive schooling or training, or willful abuse by the exhibitor is cause for disqualification.*
- 3. The horse should track straight, freely, and at the proper cadence for the prescribed gait. Transitions should be smooth and prompt in the pattern and on the rail, and should be performed when called for on the rail. The horse's head and neck should be straight and in line with its body while performing straight lines and slightly arched to the inside on curved lines or circles. Circles should be round, and performed at the appropriate speed, size, and location as requested in the pattern. The counter-canter*

*should be performed smoothly with no change in cadence or stride unless specified in the pattern.*

4. *The stop should be straight, square, prompt, smooth, and responsive with the horse maintaining a straight body position throughout the maneuver. The back should be smooth and responsive.*
  5. *Turns should be smooth and continuous. When performing a turn on the haunches, the horse should pivot on the inside hind leg and step across with the front legs. A rollback is a stop and 180 degree turn over the hocks with no hesitation. Backing during turns will be penalized severely.*
  6. *The horse should step across with the front and hind legs when performing the sidepass, leg yield, and two track. The sidepass should be performed with the horse keeping the body straight while moving directly lateral in the specified direction. When performing a leg yield, the horse should move forward and lateral in a diagonal direction with the horse's body arced opposite to the direction that the horse is moving. In the two track, the horse should move forward and lateral in a diagonal direction with the horse's body held straight or bent in the direction the horse is moving.*
  7. *A simple or flying change of lead should be executed precisely in the specified number of strides and/or at the designated location. A simple change of lead is performed by breaking to a walk or trot for one to three strides. Flying changes should be simultaneous front and rear. All changes should be smooth and timely.*
  8. *Position of the exhibitor and performance of the horse and rider on the rail must be considered in the final placing.*
- G. *Faults. Faults can be classified as minor, major or severe. The judge will determine the appropriate classification of a fault based upon the degree and/or frequency of the infraction. A minor fault will result in a 1/2 to 4 point deduction from the exhibitor's score. A major fault will result in a deduction of 4 1/2 points or more from the exhibitor's score. An exhibitor that incurs a severe fault avoids elimination, but should be placed below all other exhibitors that complete the pattern correctly. A minor fault can become a major fault and a major fault can become a severe fault when the degree and/or frequency of the infraction(s) merits.*
1. *Faults in the Overall Appearance of Exhibitor and Horse include:*
    - a. *Loose, sloppy, dirty, or poor fitting clothing or hat; or loss of hat.*
    - b. *Over-cueing with reins and/or legs.*
    - c. *Poorly groomed, conditioned or trimmed horse; or poorly or ill fitted equipment.*
    - d. *Excessive staring at judge, head held crooked, or severe turning of the head.*
    - e. *Stiff, artificial or unnatural body, leg, arm, and/or head position.*
    - f. *Reins too long or short, or uneven.*
    - g. *Loose leg with open knee, or toes pointed down.*
    - h. *Shoulders held crooked or arms held in a straight, unbent position.*

- i. Exhibitor looking down to check leads or falling forward when stopping.
  - j. Poor position of the exhibitor in saddle, legs too forward or back.
2. Faults of the Performance include:
    - a. Wrong lead or break of gait for a few strides.
    - b. Oblong or flat sided circles, or horse dropping shoulder (counter arc) when circling.
    - c. Stopping rough, crooked, or dropping a hip out when stopping.
    - d. Backing sluggishly or crooked.
    - e. Failure to maintain a pivot foot or stepping behind with the front legs when turning, or failure to complete entire 90, 180, 270 or 360 degree turn.
    - f. Holding the head and/or neck excessively crooked when moving in straight lines or when stopping or backing.
    - g. Showing resistance when cued or reined.
    - h. Hesitation during any maneuver unless specified.
    - i. Failure of horse to stand still in pattern.
    - j. Pattern work or rough transitions.
    - k. Failure to exhibit change of speed when requested.
  3. Severe Faults in the Overall Appearance of Exhibitor and Horse (avoids disqualification but should be placed below other exhibitors that do not incur a severe fault) include:
    - a. Touching horse.
    - b. Grabbing the saddle horn or any other part of the saddle.
    - c. Cueing with the end of the romal.
    - d. Spurring in front of the shoulder.
  4. Severe Faults of the Performance (avoids disqualification but should be placed below other exhibitors that do not incur a severe fault) include:
    - a. Omission or addition of maneuvers.
    - b. Turning the wrong way.
    - c. Knocking over a cone or working on the wrong side of the cones.
    - d. Kicking at other horses, exhibitors or judge.
    - e. Severe disobedience or resistance by horse including, but not limited to, rearing, bucking or pawing.
  5. Disqualifications (should not be placed) include:
    - a. Failure by exhibitor to wear correct number in visible manner.
    - b. Willful abuse.
    - c. Excessive schooling or training.
    - d. Fall by horse or rider.
    - e. Illegal use of hands on reins.
    - f. Use of prohibited equipment
- H. Suggested Final Scoring shall be on a basis of 0-20, with an approximate breakdown as follows:
1. Score of 20: Excellent equitation including body position and use of aids. Pattern is performed promptly, precisely and smoothly.
  2. Score of 18-19: Generally excellent performance with one minor fault in appearance and position of exhibitor or exe-

- cution of the pattern (performance).*
- 3. Score of 16-17: Generally good pattern execution and equitation with one minor fault in precision or execution of pattern (performance) or appearance and position of exhibitor.*
  - 4. Score of 14-15: Average pattern that lack quickness or precision, or rider has obvious equitation flaws that prevent effective horsemanship, or commits two or three minor faults in the performance or appearance and position of exhibitor.*
  - 5. Score of 12-13: One major fault or several minor faults in the performance and/or appearance and position of exhibitor that precludes effective communication with the horse.*
  - 6. Score of 10-11: Two major faults or many minor faults in the performance or appearance and position of exhibitor.*
  - 7. Score of 6-9: Several major faults or one severe fault in the performance or appearance and position of exhibitor. Exhibitor demonstrates a complete lack of riding ability or commits a severe fault in the performance or appearance and position of exhibitor.*
  - 8. Score of 1-5: Exhibitor commits one or more severe faults in the performance or appearance and position of exhibitor, but does complete the class and avoids disqualification.*

## **YP-125. REINING**

### **A. PATTERNS.**

- 1. Youth Thirteen (13) and Under.** Will use reining patterns Y1, Y2, or Y4.
- 2. Youth Fourteen (14) through Eighteen (18) and Youth Eighteen (18) and Under.** Use reining patterns Y1-Y4. See patterns.

### **B. Scoring will be as per Rule SC-260.**

## Reining Pattern Y1

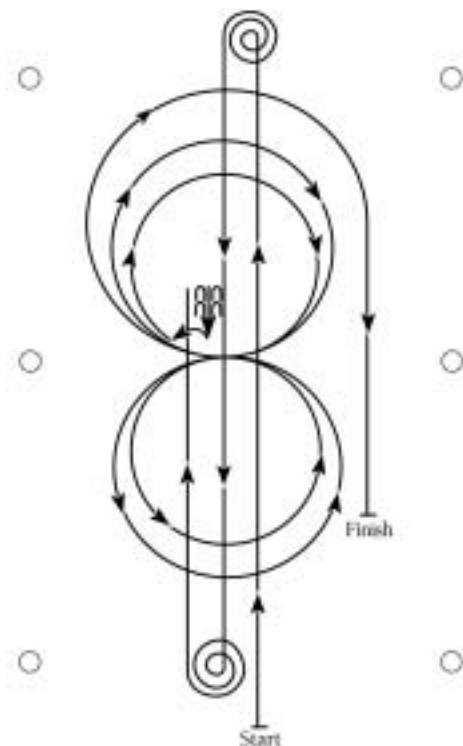

### Ride Pattern Y1 as follows:

1. Run to the far end of the arena, stop and do two and one half (2-1/2) spins to the left.
  2. Run to the opposite end of the arena, stop and do two and one half (2-1/2) spins to the right.
  3. Run past the center of the pattern, do sliding stop, no hesitation, back over slide tracks to center, hesitate. Make a one fourth (1/4) pivot to the left to face left wall, hesitate.
  4. Begin on right lead and make two (2) circles to the right, the first small and slow, the second large and fast. Change leads at center of arena.
  5. Make two (2) circles to the left, first small and slow, the second large and fast. Change leads at the center of arena.
  6. Begin a large fast circle to the right. Do not close this circle, but run straight down the side past the center, do a sliding stop. Stop at least twenty (20') feet (6.09m) from wall or fence. Hesitate to show completion of pattern.
- Rider may drop the bridle to the designated judge.

## Reining Pattern Y2

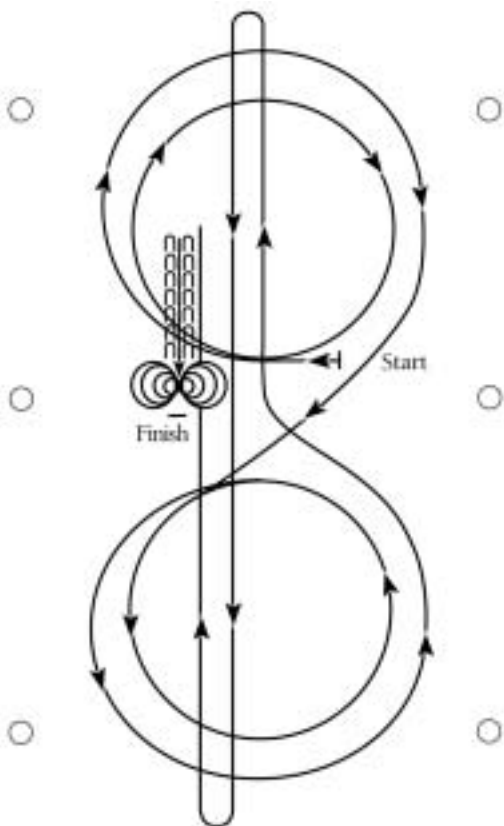

### Ride Pattern Y2 as follows:

1. Begin at center of the arena. Complete two (2) circles to the right. The first circle small and slow, the second circle large and fast. Change leads at the center of the arena.
2. Complete two (2) circles to the left. The first circle small and slow, the second circle large and fast. Change leads at the center of the arena.
3. Run to the far end of the arena, past end marker and do a left roll-back, no hesitation.
4. Run to opposite end of arena, past end marker and do a right roll-back, no hesitation.
5. Run past center of arena and do a sliding stop. Back straight to center of the arena. Hesitate.
6. Complete four (4) spins to the right.
7. Complete four (4) spins to the left. Hesitate to demonstrate the completion of the pattern.

Rider may drop the bridle to the designated judge.

## Reining Pattern Y3

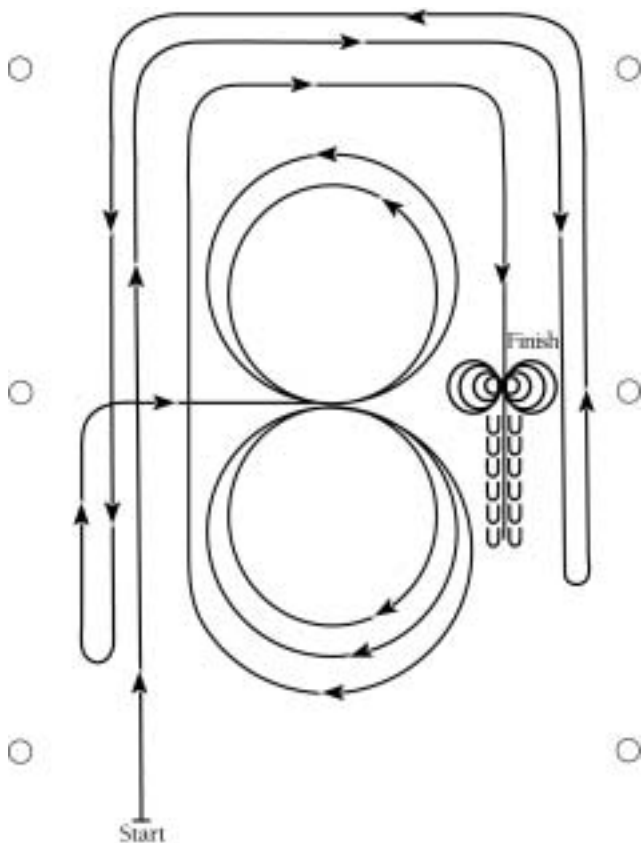

### Ride Pattern Y3 as follows:

1. Begin approximately 20 feet (6.09m) from the left wall or fence. Lope straight down the side of the arena staying 20 feet (6.09m) from the fence, circle the top end of the arena and run straight down opposite side of arena past center marker and do a left rollback.
2. Continue straight down the side at least 20 feet (6.09m) from the wall or fence and back around top of arena (horse to be on left lead at this point) running straight down the other side of arena at least 20 feet (6.09m) from the wall, past center marker, and do a right rollback. Continue up the left side of arena to center marker and at center marker horse should be on right lead, continue to center of arena on right lead.
3. Complete two circles to the right, the first small and slow, the second large and fast. Change leads at the center of arena.
4. Complete two circles to the left; the first small and slow, the second large and fast. Change leads at the center of the arena.
5. Begin a large fast circle to the right - do not close this circle. Continue straight down the side at least 20 feet (6.09m) from the wall or fence, circle the end of the arena and run straight down the opposite side of the arena past center marker and do

a sliding stop at least 20 feet (6.09m) from the wall. Back up at least 20 feet (6.09m). Hesitate\*

6. Complete four spins to the right.
  7. Complete four spins to the left. Hesitate to demonstrate the completion of the pattern.
- Rider may drop the bridle to the designated judge.
- \* Horse may come out of rollback on either lead, however, they should be on correct lead when rounding the end of the arena.

### Reining Pattern Y4

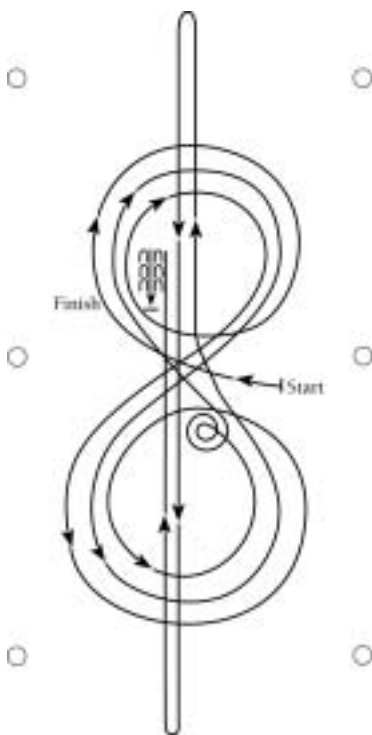

### Ride Pattern Y4 as follows:

1. Start in the center of the arena, make a large fast circle to the right. Draw the circle down to a small circle until you reach the center of the arena, stop.
2. Do two (2) spins to the inside of the small circle in the center of the arena, at the end of the spins horse should be facing the left wall, slight hesitation.
3. Begin on left lead and make a large fast circle. Then a small circle again drawing it down to the center of the arena, stop, no hesitation on these stops.
4. Do two (2) spins to the inside of the circle, slight hesitation, horse to be facing wall.
5. Begin on right lead and make a fast figure eight over the large circles, close the eight, and change leads.
6. Run to far end of arena and do a left roll back.
7. Run to opposite end of the arena and do a right roll back.

8. Run back past center of the arena and do a sliding stop. Hesitate. Back over slide tracks.  
Rider may drop the bridle to the designated judge.

### YP-130. CALF ROPING (TIEDOWN)

- A. **WESTERN ATTIRE.** See Rule SC-270.A.  
**Exception:** Safety helmet is optional.
- B. **WESTERN TACK.** See Rule SC-270.B.
- C. **GENERAL RULES.** See Calf Roping, Rule SC-280.B
- D. **REQUIRED NECK ROPE. (Tiedown Calf Roping Only.)**  
See Rule SC-270.B.2.
  1. **“Optional Keeper”.** The “optional keeper” shall be defined as a small loop attached to the noseband, approximately 6 inches (15.24cm) in length and 1/4 inch (6.3mm) in diameter consisting of rope. If a keeper is used, it must be attached to the noseband of the tiedown and cannot be attached to the bit or bridle.
- E. **JUDGED EVENT.** This is a judged event; however, a maximum of two minutes or two loops, whichever comes first, will be allowed. If both loops are missed, contestant will retire with no score.

### YP-135. BREAKAWAY ROPING

**This is a timed event with a two-minute time limit.**

- A. **WESTERN ATTIRE.** See Rule SC-270.A. Exception: Safety helmet is optional.
- B. **WESTERN TACK.** See Rule SC-270.B.
- C. This event shall be performed following the same general rules as youth calf roping. See Calf Roping Rule SC-280.
- D. Horse must start from behind a barrier. A 10-second penalty will be added to the time for breaking the barrier. Calves or hornless cattle must be used.
- E. Two loops will be permitted. One or two ropes are to be tied to the saddle horn by a heavy string, in such a manner as to allow rope to be released from the horn when the calf or hornless cattle reaches the end of the rope. A visible cloth or flag must be attached to the end of the rope tied to the horn to make it easier for the flagger to see it break free.
- F. Should the roper desire to use a second loop, he may either recoil if carrying only one rope or use a second rope tied to the saddle horn. If the second loop falls loose, it cannot be rebuilt.
- G. The contestant may free his first rope from the horn after a miss before getting his second loop ready if he wishes.
- H. The contestant shall receive no time should he break the rope from the horn by hand or touch the rope or string after the catch is made. If the rope dallies or will not break free when the calf reaches the end of it, the contestant will receive no time.
- I. Time will be called from drop of flag at barrier to the break of rope string from the saddle horn. A legal catch is to be any loop that goes completely over the head of the calf or hornless cattle and draws up on any part of the calf or hornless cattle's body, causing the rope to break away from the saddle horn.

Roping the calf or hornless cattle without releasing the loop from the hand is not permitted.

- J. The contestant shall not attempt to rope the animal until the barrier flag has been dropped. Any attempt by a contestant to position his horse behind the barrier, enabling the contestant to rope the calf or hornless cattle without leaving the barrier or box, shall be considered a disqualification.
- K. Rope may not pass through bridle, tie-down, neck rope or any other device.
- L. A judge may, at his discretion, use the ring steward, other show officials or approved APHA judges to assist as barrier judges and to help determine legal catches or any rule infractions.
- M. It is recommended, whenever possible, the judge be on horseback and flag the class.

### **YP-137. YOUTH TEAM ROPING**

- A. *TIME LIMIT. Horse being judged. There is a time limit of two minutes or two loops, whichever comes first.*

### **YP-140. GOAT TYING**

- A. **WESTERN ATTIRE.** See Rule SC-270.A. **Exception:** Safety helmet is optional.
- B. **WESTERN TACK.** See Rule SC-270.B.
- C. **COURSE DESIGN.**
  - 1. The regular rope scoreline will be used as the starting line where arena conditions permit; if it is not used, the starting line should be at least 15 yards (13.71m) from the chutes or any other marker from which the measurement is started..
  - 2. There is no set distance from the starting line to the goat but a minimum of 50 yards (45.72m) is desirable. Arena conditions will govern this distance.
  - 3. The goat should be tied to stake with a rope of at least 10 feet (3m) in length. Stake should be pounded completely into the ground so that no part of it is visible or above ground.
- D. **COURSE DESCRIPTION.**
  - 1. The exhibitor must be mounted on a horse and must ride from the starting line to the goat and dismount from the horse.
  - 2. The exhibitor must catch the goat by hand, throw the goat, cross and tie any three legs together with a leather string or piggin string, then stand clear of the goat.
  - 3. A field judge will then verify the tie.
- E. This is a timed event. Timing will start when the exhibitor crosses the starting line and will stop when the completion of the tie is signaled. For time calculations see Rule SC-290.D.5.
  - 1. **NO TIME** will be awarded if:
    - a. The tie is not secure for five seconds.
    - b. The goat breaks away because of the fault of the horse.
  - 2. **TIME PENALTY.** Should the exhibitor run over the goat rope while mounted, he will be fined 10 seconds.
  - 3. **RERUNS.** If the goat should break away, because of other than the horse's fault, it will be left to the judge's discretion

whether or not a rerun will be permitted.

### YP-150. CUTTING

- A. **CUTTING.** See Rule SC-286.
- B. **NCHA AND CCHA APPROVAL.** See Rule PR-000.

**FOR RULES TO ALL OTHER APPROVED YOUTH CLASSES NOT FOUND IN THIS YOUTH SECTION, REFER TO THE CORRESPONDING OPEN EVENT IN THE OPEN SHOW AND CONTEST SECTION OF THIS RULE BOOK.**



## Get a leg up on competition!

*Enroll in the Novice Youth Program.*

The Novice Youth program provides a great starting opportunity for youth making their first steps into the show arena.



EO. Box 961023  
Fort Worth, Texas 76161-0023  
(817) 834-2742, ext. 248  
[ajpha.com](http://ajpha.com)

## **YP-200. NOVICE YOUTH DIVISION**

- A. **INTERPRETATION OF RULES.** All rules pertaining to Youth shall govern the Novice Youth.

## **YP-205. NOVICE YOUTH ELIGIBILITY**

- A. **QUALIFICATIONS.** Same as Youth. See Rule YP-010. In addition:
1. **Limitation.** A Novice Youth exhibitor cannot have earned twenty (20) performance points (Open and /or Youth combined) in a class category, see Rule YP-250.A., in any recognized equine association in order to compete in novice classes in that category. The APHA reserves the right to check all equine associations/breed registries for points earned.
    - a. Once a Novice Youth exhibitor has earned fifty (50) Novice Youth points in a particular category, they will no longer be eligible to compete in Novice classes in that category in subsequent years.
  2. **Year Long Eligibility.** If an individual is considered a Novice upon application they will be considered a Novice for that calendar year. If an individual is considered a Novice on January 1, they may continue to show as a Novice for the calendar year, regardless of points earned.

## **YP-210. NOVICE YOUTH APPLICATION/RENEWAL**

- A. **NOVICE YOUTH EXHIBITOR CARD.** Every exhibitor competing in a Novice Youth class must possess a current Novice Youth Status card stating novice status and be in good standing with the APHA. Show management must inspect the current card or a photocopy of the current card.
1. **Application/Renewal.** Application/ renewal for a Novice Youth card shall be made on a form provided by APHA, available from them at no charge, and returned with application fees as provided below.
    - a. **Annual Fee.** There shall be an annual fifteen-dollar (\$15.00) APHA charge for said card. (See front of rule-book for fee charges.)
    - b. **Associated Fees.** Same as Youth.
  2. **Falsifying a Novice Youth Application.** Will result in disciplinary action.
- B. **OWNERSHIP REQUIREMENTS.** Same as Youth. See Rule YP-015.

## **YP-215. NOVICE YOUTH TITLES AND AWARDS**

- A. **NOVICE AWARDS.** Novice Youth awards are based solely on Novice Youth points earned. Upon earning 50 Novice Youth points per category a national participation certificate will be mailed.
- B. No other national Novice Youth awards will be given.

## YP-245. GENERAL SHOW RULES

- A. **MINIMUM CLASSES OFFERED.** *If Novice Youth classes are offered, a minimum of three Novice classes must be offered and the corresponding APHA Youth classes must also be offered. Novice Youth classes will not be held at the APHA World Championship Show.*
- B. **ORDER OF CLASSES.** *The Novice Youth class must be held prior to the corresponding Youth class.*
  - 1. *Exhibit in both Novice/Youth. Novice Youths may exhibit in the corresponding Youth class.*
- C. **JUDGING OF CLASS.** *Novice Youth classes will be judged in accordance with the corresponding Youth or Open rule for that particular event or contest.*

## YP-250. PERFORMANCE/EQUITATION CATEGORIES

- A. **APPROVED CLASSES/CATEGORIES.** *The following performance classes have been divided into twelve (12) categories and are approved for Novice Youth Points and/or participation certificates*
  - 1. *Category I*
    - a. *Barrel Racing*
    - b. *Goat Tying*
    - c. *Pole Bending*
    - d. *Stake Race*
  - 2. *Category II*
    - a. *Western Riding*
    - b. *Reining*
  - 3. *Category III*
    - a. *Hunter Hack*
    - b. *Jumping*
    - c. *Working Hunter*
  - 4. *Category IV*
    - a. *No youth classes offered*
  - 5. *Category V*
    - a. *Showmanship*
  - 6. *Category VI*
    - a. *Breakaway Roping*
    - b. *Calf Roping*
    - c. *Heading*
    - d. *Heeling*
    - e. *Steer Stopping*
  - 7. *Category VII*
    - a. *Western Pleasure*
  - 8. *Category VIII*
    - a. *Hunter Under Saddle*
  - 9. *Category IX*
    - a. *Horsemanship*
  - 10. *Category X*
    - a. *Hunt Seat Equitation*
  - 11. *Category XI*
    - a. *Trail*
  - 12. *Category XII*

- a. *Cutting*
- b. *Working Cow horse*
- c. *Team Penning*

**YP-255. NOVICE YOUTH CARD  
APPLICATION OR RENEWAL**

- A. **NOVICE YOUTH CARD.** *Every exhibitor competing in a Novice Youth class must possess a current Novice Youth Status card issued by the APHA. Novice youth applications and novice youth cards are available through the APHA according to the following fee structure.*
1. *Annual fee. There shall be an annual fifteen-dollar (\$15.00) fee for said card. Cards are valid through December 31 of the current year.*
  2. *Rush fee. Any Novice Youth cards requested in less than three (3) weeks from the date they are received in the APHA office will be considered rush work and a fee of twenty-five (\$25.00) dollars, in addition to the regular fee, must accompany the application. Rush fee is non-refundable in the case an application is denied.*
  3. *Fax fee. There shall be a fee of five (\$5.00) dollars for the use of a telecopy fax to send Novice Youth applications and to send Novice Youth cards by the same machine.*
  4. *Name Change. There shall be a fee of five dollars (\$5.00) to issue an amended Novice Youth card to reflect the Novice Youth's change of name, upon request.*
  5. *Replacement fee.*
    - a. *Replacement. To replace a Novice Youth card, written notification and a five-dollar (\$5.00) replacement fee must be received in the APHA office before the replacement card will be issued.*
    - b. *Non-receipt. If a Novice Youth card is not received within sixty (60) days from application, written notification must be received prior to the expiration of the sixty (60) day period and/or prior to the replacement card being issued. There will be a five dollar (\$5.00) fee for a replacement card unless APHA is notified of non-receipt within the sixty (60) day period specified above.*

**FOR RULES TO APPROVED NOVICE YOUTH PERFORMANCE EVENTS NOT LISTED IN THE YOUTH OR THIS SECTION, REFER TO THE CORRESPONDING OPEN EVENT IN THE SHOW & CONTEST SECTION OF THIS RULE BOOK. EXCEPTION: OPEN OR YOUTH HALTER EVENTS ARE NOT APPROVED EVENTS FOR NOVICE YOUTH.**

## RACING

This section will only include rules pertaining to pari-mutual racing. For rules on non-pari-mutual racing contact the Racing Department at the APHA office.

### **RA-000. RACING RULES AND REGULATIONS TWENTY FOURTH EDITION**

- A. **RECORD KEEPING.** The APHA is cognizant of the importance of keeping accurate records of the performance of American Paint Horses participating in races recognized by APHA. The APHA has adopted the format and basic racing regulations of the American Quarter Horse Association, including the current AQHA speed index system for rating horses with certain modifications. However, in all cases the APHA Racing Rules and Regulations will take precedence.
- B. **RACING COMMISSIONS.** The APHA does not intend for these rules and regulations to conflict in any way with state laws in regard to racing. In cases where these rules are in conflict with state laws, if any, the rules and regulations of the duly authorized racing commission shall take precedence.
- C. **RECOGNITION OF RACE RESULTS.** APHA will accept race results that include American Paint Horses in their Races. Only results of races from tracks under the supervision of the state, provincial or national racing commission or other recognized turf governing body will be accepted for recognition by APHA.
1. Races will be recognized in which all horses competing are registered with the American Paint Horse Association.
  2. Races will also be recognized in which an American Paint Horse competes with a horse registered with the following breed associations: Quarter Horses registered with the American Quarter Horse Association, Thoroughbreds registered with The American Jockey Club, The Canadian Jockey Club or The Mexican Jockey Club as well as horses registered with the Appaloosa Horse Club.
  3. A race will not be recognized in which a two-year-old competes against older horses.
  4. The American Paint Horse Association acknowledges that tracks and/or sponsors from time to time write stakes race conditions that restrict some horses registered with the APHA from competing. These Restricted Stakes Races (See RA-050. B.) will not be considered by APHA when calculating award points for Honor Roll, Superior Race Horse, or Performance Points.
  5. A Race results chart and an official program shall be filed with APHA following each day's racing by fax, on-line computer transmission or express delivery. The race results chart should include all of the necessary information to produce past performance lines. The official program should include conditions of the races, distances, names of the horses in each race, post positions, color, sex,

age, breeding, owner, trainer, jockey and weight carried.

6. Unless otherwise specified in the Official APHA Rule Book, the APHA recognizes and requests adoption by Racing Jurisdictions of the "Model Rules for Flat Racing" recommended by the North American Pari-Mutual Regulators Association (NAPRA) and/or the Association of Racing Commissioners International, Inc. (RCI).
  7. A videotape of all stakes races (including restricted) with a purse of \$15,000 or more shall be provided to APHA.
  8. An American Paint Horse may not earn a speed index or achieve Register of Merit at a distance exceeding 870 yards (795.5m) or around more than one turn; however, such races will be listed on the participating horse's race record.
  9. In cases of questionable times reported from tracks where the performance records indicate possible error, issuance of Register of Merit certificates and acceptance of the time and speed index as official is to be withheld until the race is reviewed by APHA.
  10. Any commission or breed registry ruling involving horses registered by APHA or affecting personnel engaged in American Paint Horse racing shall be filed with APHA unless the fine is less than \$500 or the suspension is less than 90 days.
  11. If the laboratory report on the chemical analysis of the urine or other specimen taken from a horse indicates the presence of a forbidden drug or medication and the horse is disqualified, the horse shall receive no official speed index or racing points for having started in the race.
- D. **REGISTRATION REQUIREMENTS FOR BREEDING STOCK HORSES.** To establish eligibility to participate in stakes races, Breeding Stock registered horses must meet the following requirements:
1. Have at least one APHA Regular Registry Paint in the 1st generation.
  2. Identified and photographed by an Identifier, Tattooer or APHA representative. Four (4) photographs will be required (front, rear, left and right side views).
  3. Identified and branded with a tattoo number on the upper lip by an APHA authorized tattoo technician. Requirements 2 and 3 must be completed at the same time in the same location.
  4. Have blood type/genetic test by DNA of the sire and dam filed with the Association from the laboratory approved by the Association.
  5. Have its parentage verified through blood type/genetic testing by DNA and on record with the APHA from a laboratory approved by the APHA.

## **RA-010. SPEED INDEX AND RACING POINTS**

### **A. SPEED INDEX.**

1. The American Paint Horse Association uses the current Speed Index System developed and adapted from the American Quarter Horse Association. The APHA also uses the track records recognized by the AQHA in establishing

Speed Index ratings. At a track where the track records recognized by the AQHA are faster than the Minimum Track records, that track's AQHA recognized track record shall be used in compiling Speed Index ratings. At tracks where the track records recognized by the AQHA are slower than Minimum Track Records, the Minimum Track Records shall be used to compile Speed Index ratings.

2. Horses starting at tracks eligible for recognition by the APHA for the first time, will receive Official Speed Index ratings compiled on the basis of track records established during the approved races or meet, or by using the Minimum Track Records, whichever may apply. Ratings obtained at such tracks, however, shall be subject to review and revision by the APHA Racing Committee.
3. If a horse should be disqualified, he will receive Speed Index and points based on time awarded him by the stewards.
4. Should a horse carry less than 120 lbs. (54.4311kg) in a race, 1/10 of a second will be added to the official time for each four pounds, or fraction thereof, less than 120 lbs (54.4311kg).

#### **B. RACING PERFORMANCE POINTS.**

1. Racing performance points will be awarded on the following basis at any of the eleven recognized distances: one point will be awarded for each race in which the horse receives an official Speed Index Rating of 60 through 69 (an official grade of B), two points for each official Speed Index Rating of 70 through 79 (an official grade of A), four points for each official Speed Index Rating of 80 through 89 (an official grade of AA), six points for each official Speed Index Rating of 90 through 100 (an official grade of AAA), and eight points for each Official Speed Index Rating of over 100 (an official grade of TOP AAA). (See RA-000. C. 4.)

#### **RA-020. ENHANCEMENT OF PENALTY RULE**

- A. Without necessity of referral or recommendation by stewards, to enhance penalties and sanctions, APHA reserves the right to independently direct disciplinary action or sanctions against individuals coming under APHA recognition by their participation in American Paint Horse racing conducted under the provisions of the APHA Official Rule Book and regulated by duly authorized state racing commissions, the results of which are accepted by APHA, in regard to the following matters:
  1. Positive lab results involving classified narcotics or drugs restricted from administration to horses entered to race;
  2. Possession of electrical devices in the course of a recognized race;
  3. Racing a ringer for fraudulent purposes; and
  4. Multiple offenses for the same ownership. Such procedure will be conducted according to Rule GR-070. Individuals may be suspended from membership and horses owned, trained and/or ridden by such individuals may be suspended from participation privileges in APHA-approved events.

## RA-030. HORSE OWNERSHIP

- A. **OWNERSHIP.** Horses entered in races shall be entered under the ownership of the record owner as shown on the registration certificate.
- B. **CLAIMING.** For information on transferring horses claimed in claiming races (See Rule RG-155. N.)
- C. **LEASES.** Horses racing under lease arrangements will be carried under the ownership of the lessee, providing the lease has been previously filed and recorded with APHA.

## RA-040. TATTOO IDENTIFICATION REQUIREMENTS AND PARENTAGE VERIFICATION

- A. **TATTOO IDENTIFICATION.** American Paint Horses participating at tracks, the results of which are recognized by APHA, require tattoo identification as following: Tattoo Identification: Unless otherwise stipulated by the responsible turf governing body, every horse registered with APHA, prior to participating in a race shall be identified and branded with a tattoo number on the upper lip by an APHA authorized tattoo technician. Refer to Rule RG-095 for rules pertaining to age determination by tooth examination and ineligibility to compete, if age shown by teeth does not correspond with age shown on registration certificate. The official tattoo identification number shall be affixed on the horse's registration certificate, filed with APHA, and become part of the identifying markings of said horse. The fee for tattoo identification by an APHA authorized tattoo technician is payable at the time of tattoo identification (see fee schedule in front of rule book).
  - 1. APHA's tattooing of an identification number on a horse is another manner of identification only, and, in no event constitutes a waiver by APHA of its privilege to correct and/or cancel a registration certificate for cause under APHA's rules and regulations, which is the express condition of its issuance as noted on the face of the certificate.
- B. **PARENTAGE VERIFICATION.**
  - 1. All horses foaled on or after January 1, 2000, shall be parentage verified through genetic testing by DNA by written analysis from a laboratory approved by the Association and filed with the Association before their first official start, regardless of the type of race. The horses' registration certificate shall be issued or reissued with the appropriate designation, "parentage verified". *All 2003 foals and thereafter must be parentage verified before they are tattooed.*
  - 2. All parentage verification must be coordinated through the APHA Field Services Department. Forms listing the appropriate fees are available through APHA.
  - 3. Any horse which cannot be parentage verified due to the death or foreign export of the sire and/or dam, may apply to the APHA Executive Committee by written application for consideration of a hardship exemption to required parentage verification.

- C. **REFUSAL TO COMPLY.** Refusal by an owner of sire, dam or foal to comply with the requirements of genetic testing, parentage verification, and/or tattoo identification, shall automatically disqualify such horse from participation in racing at tracks, the results of which are recognized by APHA, until such time as compliance with said request, and may be grounds for possible disciplinary action by APHA.

#### **RA-050. STAKES RACES**

- A. A Stakes Race is a race in which stakes of \$50.00 or more are posted by the owners of the participating horses and is still a stakes race when money or other prizes are added. In addition, no race with a purse of less than \$5,000 will be considered a stakes race. Match races shall not be eligible for stakes recognition. However, an invitational stakes race or an invitational handicap race for which owners do not contribute to the purse, but which is advertised in the regular stakes program, shall also be considered a stakes race, provided it carries a minimum purse of \$5,000 or more. Nominations must close more than forty-eight (48) hours before time for the first race of the day on which such stakes are to be run..
- B. Restricted Stakes Races are those races that restrict entries so as to exclude horses of the same class that would otherwise be eligible to enter, such as but not limited to, progeny races, one APHA-registered Paint parent races, state bred races, state foaled races, entries limited to those horses sold in a particular sale. The results of these races including monies earned and speed indexes shall be entered in the horse's permanent race records.

#### **RA-060. APHA RACING RECOGNITION PROGRAM**

- A. **RACING REGISTER OF MERIT.** Racing Register of Merit can be achieved by obtaining a speed index of 80 or higher. A speed index will only be awarded for approved electric times at recognized distances up to 870 yards (795.5m). Standard distances for qualification of Register of Merit are 220 (201.17m), 250 (228.6m), 300 (274.3m), 330 (301.8m), 350 (320m), 400 (365.8m), 440 (402.3m) and 550 yards (502.9m); standard distances for qualification of Register of Merit around one turn are 660 (603.5m), 770 (704m) and 870 yards (795.5m). Should a horse receive no speed index due to a hand-time caused by the malfunction of the electric timer; and the time would have resulted in a speed index of 80 or higher; and the hand-time is certified by track stewards, the owner of the horse may appeal to APHA for designation of the horse as a Register of Merit qualifier. Upon request, a Register of Merit certificate will be furnished to the recorded owner at time the Register of Merit is earned.
- B. **RUNNING CHAMPION AWARDS.** Running Champion awards will be awarded annually by written ballot of the APHA Racing Committee. All APHA annual racing awards will be issued to the owner of record as of December 31. The following awards will be given: Champion Running Two-Year-Old,

Champion Running Three-Year-Old, Champion Running Aged Horse (four-year-old and older); Champion Running Two-Year-Old Filly, Champion Running Two-Year-Old Gelding, Champion Running Two-Year-Old Colt, Champion Running Three-Year-Old Filly, Champion Running Three-Year-Old Gelding, Champion Running Three-Year-Old Colt, Champion Running Aged Mare, Champion Running Aged Gelding, Champion Running Aged Stallion. From the three age divisions, the overall World Champion Running Paint Horse will be selected. A suitable award will be presented to each of the three age and sex divisions for the annual running champion awards; and, the awards will be presented at the first directors/general membership meeting of the APHA following the year which the award was won. Race results received after ten (10) days from December 31, will not be used in selecting the running champions.

1. The recipient of the annual racing award for the Champion Running Breeding Stock Paint will be determined by the system described in Rule RA-060. B.

C. **APHA RACING TITLES.** The titles of APHA World Champion Running Paint Horse, APHA Champion Running Paint Two-Year-Old, APHA Champion Running Paint Three-Year-Old and APHA Champion Running Aged Paint Horse, APHA National Race Futurity Champion and APHA National Race Maturity Champion are hereby, from this date and in the future, reserved by the American Paint Horse Association for its express use. The registration certificate may be revoked permanently by the APHA if the owner thereof fraudulently advertises, claims, or holds forth that this certain horse is entitled to the aforementioned titles prior to the title being officially awarded by the APHA.

D. **APHA RACING HONOR ROLL AWARD.**

1. The APHA will make annual awards each year to the horse of each sex earning the most points during one calendar year in racing. The horse which earns the most points will be called the APHA Honor Roll Racing Mare, APHA Honor Roll Racing Gelding, or APHA Honor Roll Racing Stallion. The horse will receive an appropriately engraved trophy or plaque which shall be mailed to the owner of record as of December 31. Each of the remaining horses, 2nd through 10th, shall receive appropriate certificates which shall be mailed to the owners of record as of December 31. (See RA-000. C. 4.)
2. Breeding Stock Horse Honor Roll - method of tabulation same as Rule RA-060. D.1.

E. **MINIMUM RACING POINTS.** To qualify for any title, running champion or Honor Roll awards, the horse must have earned a minimum of 8 racing points. (See RA-010. B.1.)

F. **APHA SUPERIOR (EVENT) HORSE.**

1. See Rule SC-030.
2. See Rule RA-000. C. 4.

G. The APHA Racing Recognition applies to all races run after January 1, 2000. For transfer of ownership in claiming races see Rule RG-155.N.

## **RA-070. CUTTER AND CHARIOT RACING**

- A. *Only results of cutter and chariot racing contests conducted under the direct supervision of a state racing commission and/or the World Champion Cutter and Chariot Racing Association (WCCCRA) will be accepted for recognition by APHA.*

## **RA-080. APHA'S STATEMENT OF DISCLAIMER OF RESPONSIBILITY FOR SAFETY AT CUTTER AND CHARIOT RACING CONTESTS**

- A. *APHA will accept cutter and chariot racing contest results as official and use such results to calculate year-end awards.*
- B. *APHA does not assume or accept duty or responsibility for safety at these racing contests in regard to participants or any other third parties, or for the horses or other property thereof, which responsibility, as between APHA, and track management and WCCCRA, remains solely with track management and the WCCCRA.*
- C. *Unless otherwise specified in this rulebook, the racing rules of the WCCCRA will be utilized for the governance of cutter and chariot racing recognized by APHA.*
- D. *A cutter and chariot racing contest shall consist of a series of races constituting one complete go-round for all horses entered, each of which races shall match two or more two-horse teams pulling a cutter and driver or a chariot and driver. For a contest to be recognized, twelve teams of registered horses (24 horses) must compete.*
- E. *All American Paint Horses participating in cutter and chariot races must be properly identified.*
- F. *Cutter and chariot racing is a timed event, with placings determined on the basis of time lapsed for each team in the contest. The winning team in each contest will be the team with the least lapsed time, between the time the starting gate opens to dispatch the horses until the nose of the leading horse on such team crosses the finish line.*
- G. *Any horse finishing first, and any horse randomly selected by the stewards in a cutter and chariot racing contest shall be properly tested for the presence of unauthorized drugs or foreign substances.*
- H. *Officials of a cutter and chariot racing contest shall consist of a presiding steward and two associate stewards, a starter, a clerk of the scales and three timers. In the event an electric timer is used, there must still be two hand-timers. The time for any given team will be the time electronically recorded for that team, or the average of the hand timers in the event the electric timer is not used or fails to operate.*
- I. *To be eligible for placing, the aggregate weight of the cutter or chariot, harnesses, bridles and driver for such team must not be less than 275 pounds.*
- J. *A cutter and chariot race must be started from a closed starting gate and conducted on a straight course.*
- K. *During the course of a cutter and chariot race, if a team moves*

out of the lane in which it starts in such a manner that it interferes with or impedes another team, the offending team shall be disqualified when, in the opinion of the stewards, the outcome of the contest was affected. Any such team disqualified shall be placed behind the team or teams it fouled, and shall be given the time of the team it was placed behind, plus .01 second, or the maximum accuracy of the timer not to exceed .001 second.

- L. Register of Merit shall be awarded according to rule RA-060.A and official speed indexes shall be awarded according to rule RA-010.A.1.
- M. High Point Champions will be awarded at the end of the cutter and chariot racing season in the following categories: three-year-old colt; three-year-old filly; three-year-old gelding; aged stallion; aged mare; aged gelding. An appropriate award will be given to the horse's recorded owner as of April 1st of each year.
- N. Superior Chariot Horse will be awarded to any American Paint Horse which earns 200 chariot points.
- O. Chariot racing points will be awarded according to the point distribution for WCCCR races adapted from the American Quarter Horse Association. The AQHA point distribution chart is listed below.

1st	2nd	3rd
Place	Place	Place

**World Championship**

**Chariot Racing Finals**

1st Division . . . . .	16	10	5
2nd Division. . . . .	12	6	3
3rd Division. . . . .	10	5	3
4th Division . . . . .	8	4	2
5th Division . . . . .	6	3	2

**World Championship**

**Qualifying Races\***

**1st Division**

Two team race . . . . .	10		
Three team race . . . . .	10	5	
Four team race . . . . .	10	6	4

**World Championship**

**Qualifying Races\***

**2nd Division**

Two team race . . . . .	8		
Three team race . . . . .	8	4	
Four team race . . . . .	8	5	3

**World Championship**

**Qualifying Races\***

**3rd Division**

**State Finals – 1st Division**

Two team race . . . . .	7		
Three team race . . . . .	7	3	
Four team race . . . . .	7	4	2

**World Championship**

**Qualifying Races\***

**4th Division**

**State Finals – 2nd Division**

Two team race . . . . .	6		
Three team race . . . . .	6	3	
Four team race . . . . .	6	4	2

**World Championship**

**Qualifying Races\*—5th Division**

**State Finals – 3rd Division**

Two team race . . . . .	5		
Three team race . . . . .	5	2	
Four team race . . . . .	5	3	2

**State Finals**

**4th through 12th Division**

Two team race . . . . .	4		
Three team race . . . . .	4	2	
Four team race . . . . .	4	3	2

**Home Association Races**

Two team race . . . . .	3		
Three team race . . . . .	3	1	
Four team race . . . . .	3	2	1

*\*First four days of World Championships*

## **GUIDELINES FOR REGIONAL CLUB SPONSORED APHA APPROVED TRAIL RIDES**

- 1. The ride must be coordinated by a Regional Club in good standing with the APHA.**
- 2. Insurance and Liability is required and is the responsibility of the Regional Club.**
- 3. The Regional Club must secure a liability release and registration form from each rider\ non rider (forms provided by APHA).**
- 4. The Regional Club must obtain written permission of the landowner if the ride is to be held on private property/ proper permits must be obtained for state or federal land. (APHA forms)**
- 5. The ride must adhere to and enforce the APHA trail ride guidelines.**
- 6. Safety must always be the number one goal.**
- 7. The ride dates must be approved by APHA.**
- 8. The ride must have a minimum of 20 riders to qualify for a recognized ride.**
- 9. The ride must be open to all breeds, horse or mule.**
- 10. The ride must consist of a minimum of four (4) hours ride time.**
- 11. The APHA will assist in marketing and publicizing the ride.**
- 12. There will be no limits on distance from other regional clubs trail rides or shows on the same dates.**
- 13. The Regional Club must secure a Trail Ride Coordinator who will serve as liaison with the APHA.**
- 14. The Trail Ride coordinator must be an APHA member in good standing.**
- 15. The Trail Ride Coordinator will be responsible for laying out and enforcing the APHA trail ride guidelines.**
- 16. The Trail Ride coordinator should have a plan for emergency with both humans and animals.**
- 17. The Trail Ride coordinator should be a person capable of envisioning the trail ride from beginning to end which includes but is not limited to:**
  - a. Decide the duration of the ride.**
  - b. Securing a ride location and doing the pre-ride to make sure the trail is clean and safe.**
  - c. Secure capable trail hands who are experienced riders.**
  - d. If the ride includes overnight stay, what are the plans for stalls, camping accommodations, and meals, etc?**
  - e. Ascertain there is sufficient parking for trailers, living quarters, motor homes, etc.**

# PACKAGED just for you



APHA's members and interests are as diverse and unique as the markings on their horses. That's why we created the Paint Alternative Competition (PAC) program. PAC rewards you for showing your Paint Horses in competition outside the APHA show ring.

If you like to compete in 4-H, reining, cutting, combined training, open shows, or events sponsored by almost any other equine-related organization, call us for more information on the PAC program.

It was created for members just like you.



**American Paint Horse Association**

P.O. Box 961023 • Fort Worth, Texas 76161-0023

(817) 834-2742, extension 249 • [www.apha.com/pac](http://www.apha.com/pac)

## PAC PROGRAM



### **PR-000. APHA PAINT ALTERNATIVE COMPETITION (PAC)**

This Program is designed to promote Regular Registry and Breeding Stock Paint Horses in competition outside of approved APHA shows and contests by providing a special recognition program for their accomplishments.

The APHA may recognize and award credits in any approved event or class that is put on by a recognized association, organization or affiliate that has been approved by the APHA and has a record keeping, governing body that will sign a verification form. (EXCEPTION: Credits from other breed registries or breed associations that award national points will not count.) The following associations are approved: National Cutting Horse Association (NCHA), American Cutting Horse Association (ACHA), Canadian Cutting Horse Association (CCHA), National Reining Horse Association (NRHA), United States Team Roping Championships (USTRC), United States Combined Training Association (USCTA), American Horse Show Association (AHSA), National Barrel Horse Association (NBHA), International Professional Rodeo Association (IPRA), Women's Professional Rodeo Association (WPRA), Professional Rodeo Cowboys Association (PRCA), United States Team Penning Association (USTPA), National Reined Cow Horse Association (NRCHA), United States Dressage Federation (USDF), United States Pony Club (USPC), National Snaffle Bit Association (NSBA), North American Trail Riding Conference (NATRC), and 4-H.

Any club or association that is not listed above can be approved by the APHA for PAC credits and awards. To receive approval for a club or associations, club management must complete a PAC Approval Application which will be reviewed by the APHA before PAC credits will be awarded. NOTE: The APHA will have final approval of all association and/or events. PAC Approval Applications are available from the APHA Performance Department.

An enrollment application will need to be completed yearly for horses wanting to compete in this program. As of January 1, 2001, the annual enrollment fee is \$25 per horse and the enrollment is

active from January 1st through December 31st. In order for the horse to receive any awards or certificates, the owner of the said horse must be a current member of the APHA.

The enrollment application and \$25 (\$60 non-member fee) must be returned to the APHA office. Upon receipt, an enrollment card and show report forms will be forwarded and must be received in your possession prior to your competition in APHA-approved PAC events.

Show secretary/manager must inspect the PAC card, along with registration certificate and sign show report form prior to submitting the forms to APHA. Exhibitor and owner must also sign the form and return it to the APHA within thirty (30) days of the show or event.

CREDITS: Refer to Rule SC-060.A.1. for method of tabulation only . At the APHA's discretion, some events may warrant credits being earned for completion only. Other criteria for earning credits may be established or amended by the PAC Committee. For details, contact the APHA Performance Department.

## **AWARDS**

### **PR-010. PAC CERTIFICATE OF RECOGNITION**

- A. The purpose of the Certificate of Recognition is to establish a record of excellence.
  - 1. Horses are awarded a Certificate of Recognition when they have been awarded at least twenty (20) credits in any one approved category. A horse may receive this award for each separate class or event in which it has earned twenty (20) credits.

### **PR-020. PAC CERTIFICATE OF ACHIEVEMENT**

- A. The title "APHA Certificate of Achievement" will be awarded to horses that have earned sixty (60) or more credits in any one approved category. A horse may receive this award for each separate class or event in which it has earned sixty (60) credits.

### **PR-030. PAC YEAR END LEADERS**

- A. The APHA will make annual awards based upon the number of credits earned by an individual horse during the calendar year's competition in each category.
- B. The horse that earns more credits during the calendar year than any other horse has earned in that category will be the year's high-point earner for that category and an appropriate award will be awarded to the horse's owner.
- C. To qualify for any PAC Leader titles, the horse must have earned at least ten (10) credits in that category during the year.

### **PR-040. SIX PAC TOP FIVE**

- A. Year end awards will be given to the top five horses that earned the most credits in at least six different categories. Credits for each horse will be compiled separately. All ownership and PAC requirements must be met to be eligible for these awards.

## PR-050. SIX PAC CHAMPION

- A. The title of Six PAC Champion will be given to a single horse that wins at least six different categories on the PAC Leader's List in a single year. All ownership and PAC requirements must be met to be eligible for this award.

## PR-060. PAC APPROVED CATEGORIES

Barrel Racing (Restricted to Cloverleaf)	Halter
Combined Training	Handicap Competitions (Competitions approved by a nationally recognized organization such as NARHA)
Cutting	Over Fences
Dressage	Reining
Driving	Roping
*Endurance & Competitive Trail Riding	Showmanship
English Pleasure	Team Penning
Equitation	Trail
4-H English	Western Pleasure
4-H Western	Western Riding
4-H Showmanship English	Working Cow Horse
4-H Showmanship Western	Working Ranch Horse
4-H Timed Events	Yearling Longe Line
Games	

### *PAC Credit System for 4-H Events*

<i>Purple Ribbon</i>	<i>3 credits</i>
<i>Blue Ribbon</i>	<i>2 credits</i>
<i>Red Ribbon</i>	<i>1 credit</i>
<i>White Ribbon</i>	<i>0 credits</i>

### *PAC Credit System for NBHA Events*

*If the competition is a 4-D event, the following will apply for number of entries.*

- 1-D All horses competing.*
- 2-D Only horses qualified for 2-D, 3-D, and 4-D.*
- 3-D Only horses qualified for 3-D and 4-D.*
- 4-D Only horses qualified for 4-D.*

*If the competition is a 3-D event, the following will apply for number of entries.*

- 1-D All horses competing.*
- 2-D Only horses qualified for 2-D and 3-D.*
- 3-D Only horses qualified for 3-D.*

### *PAC Credit System for Dressage Events*

*Training, First and Second Levels (Must receive a score of at least 55% to earn credit.)*

- 1st place 4 credits*
- 2nd place 3 credits*
- 3rd place 2 credits*
- 4th place 1 credit*

*Any horse receiving a score of 60% or better and not placing*

*in the above credit standings will receive 1 credit for completion.*

**\*\*Dressage Credit System for PAC exhibitors differs in Third and Fourth Level Competitions.\*\***

*PAC Credit System for Combined Training  
Horse Trials*

<i>1st place</i>	<i>5 credits</i>
<i>2nd place</i>	<i>4 credits</i>
<i>3rd place</i>	<i>3 credits</i>
<i>4th place</i>	<i>2 credits</i>
<i>5th place</i>	<i>1 credits</i>

**\*\*Combined Training Credit System differs for Two Day Events and Three Day Events.\*\***

*PAC Credit System for Endurance Events*

- 1 credit for completion for less than 49 miles.*
- 2 credits for completion for 50-99 miles.*
- 3 credits for completion for 100 and multi-day.*
- 1 credit for "Best Condition Award."*

The American Paint Horse Association will have final approval of all classes or events. All classes must comply with the categories that are approved by the APHA.

**\*COMPETITIVE AND ENDURANCE  
TRAIL RIDING**

For rules regarding competitive and endurance trail riding, contact the **North American Trail Ride Conference (NATRC), P.O. Box 2136, Ranchos de Taos, New Mexico 87557**, (505) 751-4198, and the **American Endurance Ride Conference (AERC), at 701 High Street, Suite 203, Auburn, Ca 95603**. (916) 823-2260. See Rule PR-000. for approval of NATRC or AERC Competitive and Endurance.

## APHA RIDE AMERICA PROGRAM

This program is designed to promote members and their Regular Registry and Breeding Stock Paint Horses, who ride or drive for recreation and leisure purposes by providing a special recognition program for their achievements.

### Qualifications and Rules:

- Participants must be current APHA or AjPHA members and must maintain membership for the entire time in which hours are recorded toward a recognition level.
- Submit an enrollment application and one-time enrollment fee of \$25 per horse/rider combination to the Association (as of January 1, 2000).
- Ride or drive an American Paint Horse - Breeding Stock or Regular Registry. Participants do not have to own the horse.
- Time may be recorded for any activity in which you participate by riding or driving. You can also log time spent in the saddle or cart while riding in a group or parade.
- Participants must maintain a separate log on each registered American Paint Horse enrolled.
- Keep track of time (one hour for each hour actually spent riding or driving) on the official Ride America Time Log. Time logs may also be entered on the APHA web site at [www.apha.com/rideamerica](http://www.apha.com/rideamerica).
- All time figured is on a one-horse/one-rider basis and is on the honor system.
- Earn double hours by riding in national and state parks, grasslands or historic areas, as recognized by the U.S. or Canadian National Parks Service (2 hours of credit for every hour ridden).
- Participants are responsible for sending in Ride America Time Logs to the Association in order to earn awards.

### Award Levels:

100, 500, 1,000, 1,500, 2,000, 2,500, 3,000, 3,500, 4,000, 4,500, 5,000-hour awards will be given. Patches will be awarded at all levels and prizes will be given for the 500 to 5,000 hour levels.

APHA reserves the right to substitute prizes of equal value.

## AjPHA BY-LAWS

### AMERICAN JUNIOR PAINT HORSE ASSOCIATION CONSTITUTION

#### ARTICLE I Name and Purpose

**Section 1.** This organization shall be named the American Junior Paint Horse Association (AjPHA). AjPHA shall operate within the scope of the bylaws, rules and regulations and be a division of the American Paint Horse Association (APHA).

**Section 2.** The objectives and purposes of the American Junior Paint Horse Association shall be as follows:

- A. To improve and promote the American Paint Horse breed.
- B. To improve and develop the capabilities of Youth, both individually and through group participation, in the breeding, raising and exhibition of American Paint Horses.
- C. To develop and improve scholarship, leadership and community interest and participation of young people.
- D. To encourage high moral character, sportsmanship and clean living among its members.
- E. To create, foster and assist subsidiary regional junior clubs composed of members of the AjPHA.
- F. To acquaint junior members and clubs with the parent organization, APHA, its structure and functions.
- G. To guide to maturity in sportsmanship and exemplary conduct in all phases of competition.
- H. To instill a sense of responsibility to life and the rigors of showmanship.
- I. To coordinate all Youth activities including the junior regional clubs and to assist in keeping and maintaining the Youth records in conjunction with the APHA.
- J. To determine infractions of this statement of purpose and to recommend suitable penalties as well as to determine and arbitrate controversies between junior regional clubs.
- K. To advise, counsel, report activities, desires and actions of the American Junior Paint Horse Association to the APHA Youth Committee.
- L. To propose rules to the Youth Committee that represent the interest of all Youth.

#### ARTICLE II Membership

**Section 1.** Organizational Membership. This organization shall have the following classifications of membership.

- A. Club or Organizational Members, consisting of regional junior clubs.
- B. Individual Members, consisting of young people 18 years of age and younger who are not married or divorced.
- C. Voting privileges in the organization will be vested in AjPHA members or Directors or Executive Committee.

D. Membership in the AjPHA is a privilege and can be revoked on abuse of same including violations of the intents and purposes above, as well as intentional disregard of authority and violations of the rules and regulations of the APHA and the AjPHA.

**Section 2.** Approval of AjPHA Regional Clubs. Any group desiring to charter a "regional junior club" should obtain an application for regional club affiliation and an information packet from the Director of Youth Activities of the APHA that will contain step by step instructions on how to proceed with the petition of charter for Regional Junior Club status. (See Article XI - Youth Club in APHA bylaws.)

Any group desiring to form a youth Paint Horse club must first make application to their APHA Regional Club as to the reason and necessity of its formation, and shall first submit their completed By-Laws and Constitution for approval to the sponsoring regional club. The sponsoring regional club is to send to the APHA Director of Youth Activities: 1) a copy of minutes of the sponsoring regional club's meeting reflecting a vote of approval of the formation of the Youth Club; 2) the approved Youth Club's application, signed by the sponsoring regional club's president, and the Youth Club's completed By-Laws and Constitution.

Applications for Regional Junior Club charters shall be reviewed by the Youth and Regional Club Committee with recommendations for approval/denial being forwarded to the AjPHA Advisory Board.

A Regional Junior Club is eligible to be recognized and considered in good standing by the AjPHA and its advisory board and given the designation "regional junior club" (as approved by the AjPHA advisory board) when the following conditions are met:

- A. A minimum of ten AjPHA members
- B. Youth club members must be paid up in the state or area regional club, either as a youth or family member.
- C. The age limit for youth club membership is eighteen (18) years as set forth in paragraph YP-010.A. of the current APHA Rule Book.
- D. The youth club application, by-laws and constitution shall coincide with the AjPHA Constitution.
- E. An advisor or committee shall be appointed by the parent (regional) club to assist the youth club.
- F. Each youth club must send by April 1st of each year a current membership list, a current list of officers and the name(s) of the current adult advisor(s) to the APHA.

### **ARTICLE III**

#### **Directors**

**Section 1.** The business and property of the organization shall be managed and controlled by the Board of Directors and an Executive Committee hereinafter created and empowered.

**Section 2.** Directors. Annually, AjPHA state resident(s) member(s) in good standing will elect their state director(s).

**Section 3.** Allocation of Directors. Allocation of directors per state with AjPHA membership will be made as of December 31, of the year prior to the current year's director elec-

tions. The AjPHA President may appoint director(s) when necessary to establish representation. In states where there is more than one regional club, the allocation of directors will be equal among clubs. Any odd numbers of directors will be allocated to the regional club with the highest AjPHA membership.

- A. One (1) director shall be allocated to states with 1-9 active resident AjPHA members in good standing.
- B. Two (2) directors shall be allocated for each state with 10-19 active resident AjPHA members in good standing.
- C. Three (3) directors shall be allocated for each state with 20-29 active resident AjPHA members in good standing.
- D. Four (4) directors shall be allocated for each state with 30-39 active resident AjPHA members in good standing.
- E. Five (5) directors shall be allocated for each state with 40-75 active resident AjPHA members in good standing.
- F. Six (6) directors shall be allocated for each state with 76-115 active resident AjPHA members in good standing.
- G. Seven (7) directors shall be allocated for each state with 116 or more active resident AjPHA members in good standing.

**Section 4.** Director Eligibility. The term of office will begin following the election of officers at the AjPHA Convention and end at the close of the next year's AjPHA Convention. Those who are elected must be 17 or under as of January 1 of the year they take office and must be a current member of the AjPHA. Each director shall be a bonafide resident of the state he/she represents and a member in good standing with the AjPHA. Should a director move from his/her state, the director may complete the remaining time of his/her term.

**Section 5.** Director Election Procedure.

- A. AjPHA members are eligible to vote on their state's directors. Nominees for directors will be taken from states with regional junior clubs and regional clubs with AjPHA membership on January 1. In addition, an individual may apply for nomination upon submission of the signatures of five AjPHA current members in good standing and residing in the same state, evidencing endorsement of the nominee.
- B. There shall be a youth national directors nominating committee comprised of the APHA Youth Coordinator, APHA Youth Committee Chairperson, AjPHA President and two AjPHA Zone Representatives selected by the AjPHA President and publicly announced by January 1.
- C. After January 1, this committee shall review and prepare a ballot for each state using qualified recommendations of the regional junior clubs, its own nominations, and individual nominations accompanied by the appropriate five members signatures.
- D. The AjPHA state membership will be sent a ballot containing the names of the state nominees. These ballots must be received at the APHA as of March 1. Election results will be printed in the Paint Horse Journal. Write-in candidates will be accepted in addition to those contained on the ballot. Those who are elected must be 18 or under at the time they take office.
- E. The AjPHA President may also at his/her discretion appoint up

to three (3) additional directors to serve during his/her term of office.

**Section 6.** Directors at Large. In addition to the directors so elected, all President-Elects and Past Presidents of the AjPHA shall become Directors at Large until they are no longer eligible to participate as outlined in the age requirements. (See Article II, Section 1. B.)

**Section 7.** Vacancy in the Board of Directors. In the case of any vacancy in the Board of Directors, the AjPHA President may appoint a successor to fill the unexpired term of the state's director provided the successor is an AjPHA member from the same state. The AjPHA must be notified in writing of the vacancy or resignation of a Director.

**Section 8.** Meetings of the Board of Directors. The regular meeting of the Board of Directors shall be held at such time and place as may be fixed by the Executive Committee of the organization for the purpose of electing officers and for the transaction of such other business as may be brought before the meeting. Special meetings of the Board of Directors may be held at such time and place as may be designated in the notice, whenever called in writing by the direction of the President or by a majority of the Board of Directors. Each Director may be required to attend at least one of the meeting(s) held each year.

A. Notice of Meetings of the Board of Directors. Written or printed notice of all meetings stating the place, date and hour of meeting and in case of a special meeting, the purpose or purposes for which the meeting is being called, shall be post-marked not less than thirty (30) days before the date of the meeting. This notice will be made in person, by mail or by publication in the *Paint Horse Journal* to each member of the Board of Directors or recognized regional junior club at the direction of the President or Secretary, or the officer or person calling the meeting. If mailed, such notice shall be deemed to be delivered, upon deposit in the United States mail. It shall be addressed to the Board of Directors or the regional junior clubs at their address as it appears on the records of the Association with postage thereon paid.

**Section 9.** Quorum of the Board of Directors. At any meeting of the Board, the directors present are sufficient to establish a quorum.

**Section 10.** Powers of the Board of Directors. The Board of Directors shall have the authority to direct the affairs of the organization, including, but not limited to, the right to make, amend and repeal the constitution of the organization, as they may deem expedient concerning the conduct, management and activities of the organization, the admission, classification, qualification, suspension and expulsion of members, removal of officers, expenditure of money and other details relating to the general purposes of the organization which may be subject to the approval of the Advisory Board

## ARTICLE IV

### Executive Committee

**Section 1.** Executive Committee (Officers). The

Executive Committee of the organization shall be the President, President-Elect, Vice President, Secretary, Treasurer, and eight additional members consisting of one representative from each zone (1-8). These officers may be subject to approval by the Advisory Board of the organization. All officers must be an elected director of the AjPHA for the year in which they are elected to serve.

**Section 2.** Election Procedure of the AjPHA Executive Committee. The Executive Committee of the AjPHA will be elected by a simple majority of the AjPHA directors present at its annual meeting at the AjPHA Convention. Elections for each position will be held individually starting with President. The AjPHA Executive Committee will be elected at the annual Board of Directors meeting held during the AjPHA Convention. All AjPHA directors present will be eligible to vote. The officers of the AjPHA Executive Committee will be elected from the zones that are represented. Each zone may have no more than two representatives serving as officers (President, President Elect, Vice President, Secretary or Treasurer) during the same term. Note: Zone Representatives are excluded from the two(2) person maximum on the Executive Committee.

- A. President. The President shall be the chief executive officer of the Association and shall have the general supervision of the affairs of the Association, subject to the direction of the Board of Directors, and shall preside at all meetings of the members of the Board of Directors. The President shall submit to members annually at their meeting a report of the status of the Association and its activities during the preceding year. No director of this Association may serve more than one year as President.
1. The President shall have other and further duties and authority as may be prescribed elsewhere in this constitution or, from time to time, by the Board of Directors.
  2. The AjPHA President will receive an AjPHA membership and *Paint Horse Journal* subscription during his/her term in office.
- B. President-Elect. In the absence of the President, the President-Elect shall have the power and shall perform the duties of the President and such other duties as may be prescribed by the Board of Directors. Upon the expiration of the President's term of office, the President-Elect shall automatically become President. Those elected must be 17 or under on January 1 following the election.
- C. Vice-President. The Vice-President shall, in the absence (disability or inability) of the President and President-Elect, perform the duties and exercise the powers of the President, and shall perform such other duties as the President shall, from time to time, prescribe.
- D. Secretary. The Secretary shall attend all meetings of the members of the Board of Directors and shall record and cause to be recorded all votes taken and the minutes of all proceedings in a minute book of the Association to be kept for that purpose. The Secretary shall perform like duties for the committees when requested. The Secretary shall have the responsibility to give

or cause to be given notice of all meetings of the Board of Directors and the members. This shall not lessen the authority of others to give such notice as provided in this constitution.

E. Treasurer. The Treasurer shall render to the President of the Association and to the Board of Directors, whenever requested, an account of the financial condition and all financial transactions of the Association. In addition, the Treasurer shall make an annual report to the membership. The Treasurer will work with the APHA accountant to determine information as to the AjPHA's financial condition.

F. Zone Representatives.

1. At the annual meeting of the Board of Directors, one Zone Representative from each zone (1-8) will be elected from the board of directors. These eight Zone Representatives will serve as additional members to the Executive Committee.
2. In addition to the above duties, Zone Representatives shall strive to keep the AjPHA general membership in their respective zones informed about AjPHA/APHA activities and promote the AjPHA whenever possible. This may be accomplished by attending regional club meetings, the meetings of other organizations and by forwarding written materials to regional club officers in the zone that they represent. Zone Representatives should funnel ideas, concerns and comments from members to the APHA Youth Coordinator.

**Section 3.** Executive Committee Eligibility. All officers must be a current director of the AjPHA. Such officers shall hold offices for a period of one (1) year and until their successors are elected and qualified. The term of office will begin following the election of officers at the AjPHA Convention and end at the close of the next year's AjPHA Convention. Those who are elected must be 18 or under on January 1 following the election with the exception of the President-Elect who must be 17 or under. (See Article IV, Section 2. b.) If a youth reaches the age of 19 after he/she is elected to office, he/she will still be eligible to complete his/her term of office. No officer or member of the Executive Committee may serve on the Executive Board in excess of four (4) consecutive years.

**Section 4.** Vacancies of Executive Committee. All vacancies in the Executive Committee of the AjPHA shall be filled by the AjPHA Executive Committee from the Board of Directors of the zone in which the vacancy occurs for the unexpired term. Those so appointed shall serve until the election and acceptance of their duly qualified successors. Any vacancy may be reported in writing to the AjPHA by regional club (adult or junior), or Adult Advisor, or the individual resigning.

**Section 5.** Notice of Meetings of the Executive Committee. The Executive Committee shall meet whenever and wherever called by direction of the President or three (3) members of the committee acting jointly. The Secretary shall give written notice for said meeting postmarked fourteen (14) days prior to the meeting, but such notice must be given.

**Section 6.** Powers of the Executive Committee. All pow-

ers of the Board of Directors shall be and are hereby vested in the Executive Committee. During the interim between annual meetings or special meetings of the Board of Directors, the Executive Committee is empowered to direct the affairs of the organization.

**Section 7.** Quorum of the Executive Committee. At any meeting of the Executive Committee, the committee members present are sufficient to establish a quorum.

## **ARTICLE V**

### **Recall**

**Section 1.** Recall. Any member of the Board of Directors may be removed from office with just cause. A recall may be conducted at the AjPHA meetings provided written notification is post-marked thirty (30) days prior to the meeting. A recall may be acted upon provided a majority of the Board of Directors present vote in agreement.

## **ARTICLE VI**

### **Advisory Board**

The Advisory Board of this organization shall consist of the APHA President, APHA Director of Youth Activities, the Youth Activities Committee, and the Executive Secretary of the APHA. This Advisory Board shall notify the Youth Activities Committee of the actions of this organization and all actions taken by the AjPHA Board of Directors or Executive Committee may be subject to the Advisory Board's approval.

## **ARTICLE VII**

### **Place of Business**

**Section 1.** The place of business of the Association shall be the APHA headquarters in Fort Worth, Texas.

**Section 2.** All correspondence regarding the AjPHA shall be directed to the APHA headquarters in Fort Worth, Texas, to the attention of the Youth Activities Director.

## **ARTICLE VIII**

### **Amendments**

The Board of Directors and/or the Executive Committee shall have the power to make, amend and appeal the By-Laws of the Association by vote of the members present at any regular or special meeting, which may be subject to the right of the Advisory Committee to rescind or amend any such By-Laws.

## **ARTICLE IX**

### **Committees**

The President shall have the authority to appoint all committees and committee members as the President deems appropriate. Approval of committees and committee members may be subject to the Advisory Committee's consideration.

**ARTICLE X**  
**AjPHA Zones**

**Section 1.** AjPHA Zones. Zone areas are numbered 1 through 8 from the West Coast to the East Coast. The regions shall be designated as shown on the zone map. These regions are established by the AjPHA Executive Committee for the purpose of director elections and award programs. Zone lines will not be determined on the basis of competition per zone. Junior clubs of foreign countries or provinces of Canada will participate in the region closest to their club headquarters. See Zone Map, Rule SC-105.B.3.f. for states listed in each zone.



Join AjPHA as it marks 30 years of combining  
young people and Paint Horses.

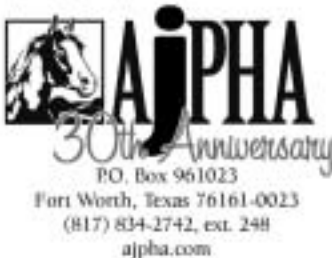

## AMERICAN JUNIOR PAINT HORSE ASSOCIATION

Become a junior member and receive an AjPHA new member packet which includes: member card, memento, decal, rule book (upon request), activities calendar and quarterly AjPHA newsletter. A membership form can be found on page 258.

The following is a list of activities and information available from APHA. Contact the Youth Coordinator for more information.

### **Educational Resources/Printed Material:**

- AjPHA Source Book (FREE)
- Western Horsemanship Video
- Western Riding Video
- AjPHA Brochure (revised 2001)

### **Contests:**

- Essay contest
- Art Contest
- (APHA) Photo contest
- Club of the Year
- Youth of the Year
- Youth Activity Team Tournament
- World Championship Horse Judging Contest
- Buckle Coloring Contest (at World Show)
- Talent Contest (at World Show)
- From the Heart Award

### **Programs/Services:**

- Ride America
- Paint Alternative Competition (PAC)
- YDF Scholarship Program
- New Horizons Academic Courses on the American Paint Horse
- AjPHA/APHA website access

### **Special Events:**

- APHA Youth World Championship Show
- Year-End Awards Banquet (at World Show)
- Youth Leadership Conference

### **Merchandise:**

- Special AjPHA merchandise available through the The APHA General Store
- Youth Activity Book

## DESCRIPTION OF AMERICAN PAINT HORSE COLORS

**BAY:** *body color reddish brown, with variations ranging from dark blood bay to light bay and usually distinguished by black mane and tail, ear tips, lower legs.*

**BLACK:** *entire coat, including muzzle, flanks, and legs, are black; color may fade when exposed to the sun; could have rusty tinge during certain times of the year; early foals may be an overall mousy grey, then shed to black.*

**BROWN:** *body color brown or black with light areas at muzzle, eyes, flank and inside upper legs; mane and tail usually black.*

**SORREL:** *body color reddish or copper-red; mane and tail usually same color as body, but may be flaxen or very dark brown.*

**CHESTNUT:** *body color dark red or brownish red; variations range from very light to liver chestnut; liver chestnut can be distinguished from black or brown only by the bronze or copper highlights on the legs; mane and tail usually dark red or brownish red, but may be flaxen.*

**DUN:** *diluted body color of yellowish or gold; mane and tail are black or brown; has dorsal stripe and usually zebra stripes on legs and transverse stripe over withers (hereafter called primitive markings).*

**RED DUN:** *a form of dun with body color yellowish or flesh colored; mane and tail are red or reddish; has red or reddish primitive markings.*

**GRULLO:** *a form of dun with body color smoky or mouse-colored (not a mixture of black and white hairs, but each hair mouse-colored); mane and tail black; has black primitive markings.*

**BUCKSKIN:** *body color yellowish or gold, mane and tail black; black on lower legs; lacks primitive markings.*

**PALOMINO:** *diluted body color varying from rich gold to pale yellow; mane and tail generally pale or off-white but may be same color as body (with nonblack points).*

**GRAY:** *dominant over all other color genes; born any color with white hair progressively turning the coat whiter as the horse ages; dark skin; normally grays first around eyes and behind ears.*

**RED ROAN:** *the overall intermingling of white hairs with chestnut/sorrel body color; head, lower legs, mane and tail are usually sorrel or dark red; does not get progressively whiter with age.*

*BLUE ROAN: the overall intermingling of white hairs with a black body color; head, lower legs, mane and tail are usually solid or darker; does not get progressively whiter with age.*

*BAY ROAN: the overall intermingling of white hairs with bay body color; head, lower legs, mane and tail are usually solid or darker; does not get progressively white with age.*

*CREMELLO: double dilute of chestnut/sorrel resulting in body color, mane and tail of cream or off-white with pale, pinkish skin; the coat has enough yellow hue to allow white markings to be visible; eyes are blue or amber.*

*PERLINO: double dilute of bay/brown resulting in body color of cream or off-white; lower legs, mane tail light rust or chocolate shade; skin is pinkish or grey; eyes are blue or amber; the coat has enough yellow hue to allow white markings to be visible.*

**TOBIANO-OVERO CROSS PATTERNS  
HORSES SHOW CHARACTERISTICS OF  
BOTH COLOR PATTERNS**

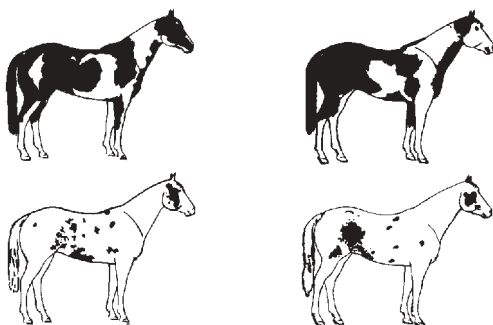

**METRIC SYSTEM**

<b>Unit</b>	<b>Abbreviation</b>	<b>Number of Meters</b>	<b>Approximate U.S. Equivalent</b>
<b>kilometer</b> (1mile equals 1.6094 kilometers)	<b>km</b>	<b>1,000</b>	<b>0.62 mile</b>
<b>meter</b> (1 yard equals 0.9144 meter)	<b>m</b>	<b>1</b>	<b>39.37 inches</b>
<b>centimeter</b> (1 inch equals 2.54 centimeters)	<b>cm</b>	<b>0.01</b>	<b>0.39 inch</b>
<b>millimeter</b>	<b>mm</b>	<b>0.001</b>	<b>0.04 inch</b>

THE AMERICAN PAINT HORSE  
TYPICAL PAINT HORSE  
COLOR PATTERNS



## IDENTIFICATION GUIDE TOBIANO

The head will usually be marked like a solid-colored horse, either being solid or having a blaze, stripe, race or star and snip.

All four legs will usually be white, at least below the hocks and knees. However, one or more legs may be dark below the hocks or knees. Body markings will usually be regular and distinct, often being oval or round patterns that extend down over the neck and chest giving the appearance of a shield.

The Tobiano Paint will usually have the dark color in one or both flanks. The Tobiano may either be predominantly dark or white.

## OVERO

The head markings on the Overo Paint are often bald, apron or even bonnetfaced.

At least one leg, and often all four legs will be dark color. Body markings on the Overo are usually irregular, rather scattered and/or having splashy white markings, often referred to as calico patterns.

Usually the white will not cross the back between the withers and the tail. The tail will usually be only one color.

The Overo Paint may either be predominantly dark or white.

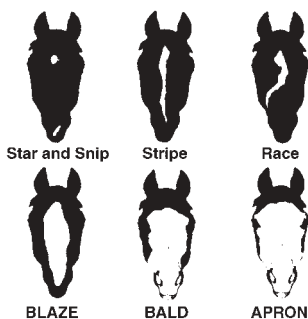

### TYPICAL HEAD AND LEG MARKINGS ON THE AMERICAN PAINT HORSE

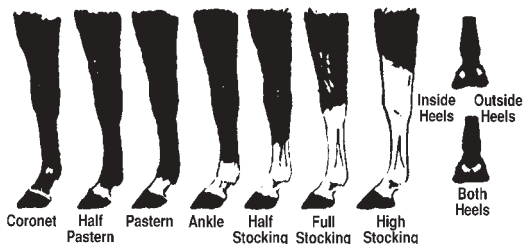

## ENGLISH ATTIRE AND TACK\*

Hunter Under Saddle - Hunter Hack - Working Hunter - Jumping

### Personal Appointments:

English Coats - Tweed or Melton  
Conservative Wash Jackets (in season)  
Breeches or Hunt Jodphurs  
High English Boots or Jodphur Boots  
Hunting Cap (Dark Blue, Black or Brown)  
Hunt Derby (Black or Brown)  
Stock Tie or Choker  
Safety Helmet\*\*

### Optional Appointments:

Spurs (unrowelled)  
Crops or Bats  
Braiding of mane & tail in hunt type.  
Roached mane allowed.

### Prohibited Appointments:

Spurs (Rowelled)

### Tack:

Saddles - Hunt Seat or Forward Seat Type; Heavy Leather  
Bridle - Regulation Hunt Bridle with Cavesson Noseband  
Reins - Regulation Hunt Rein or Double Reins with Double Bits

### Optional Tack:

Hunting Breast Plate  
Artificial Tail Braid  
and Browband is acceptable.

### Prohibited Tack:

Running and Standing Martingales,  
Dropped Nosebands, Draw Reins  
Curb Chain Narrower than a half-inch  
Leg Wraps and/or Boots

### Bits:

English Snaffle (no shanks), Kimberwick or Pelham  
Double Bridle Bits - Curb or Weymouth & Snaffle or Bradoon  
See Rule SC-200.A.3.-4. on bit description.

### Prohibited Bits:

Three-Piece Mouthpiece for 2-Year-Olds-Hunter Under Saddle  
Cathedral, Fishback or Donut Mouthpiece  
Rough, Sharp Material or Mechanical Altered Bits

**\*EXCEPTIONS:** Working Hunter: running and standing martingale permitted. Jumping: running and standing martingale permitted. Bits: corkscrew, doubled twisted, dull edge mouthpiece permitted.

\*\*Helmet with harness properly attached under the chin is required for all youth participating in any warmup/schooling area or class (including open) involving jumps, excluding trail.

## PLEASURE AND UTILITY DRIVING

### **Personal Appointments:**

Long Sleeves  
Coat and Tie of Choice  
A Hat of Choice  
Lap Robe Required with Ladies Short Dresses

### **Optional Appointments:**

Rainwear or  
Inclement Weather Apparel

### **Prohibited Appointments:**

### **Cart:**

Pleasure Type, Two-Wheeled Single-Horse.  
Seat for one or two. Basket type equipped.

### **Optional Cart Accessories:**

Dash and/or Basket Cover

### **Prohibited Carts:**

Stirrup Type  
Sulkies

### **Tack:**

Collar or Breast Collar Harness with Breaching or Thimbles  
Standard Bridle  
Two Reins and Cavesson Noseband and Browbands  
with Double Bits

### **Optional Tack:**

Overcheck or Check Reins  
Blinders  
Running Martingales  
Cavesson Nosebands  
Breaching or Thimbles

### **Prohibited Tack:**

No Converters with Double Bits/Two Reins

### **Bits:**

English Snaffle (no shanks), Kimberwick, Pelham  
Double Bridle Bits-Curb or Weymouth & Snaffle or Bradoon  
Also, Half Cheek Snaffle, Liverpool, Elbow Driving  
and Bradoon Overcheck  
See Rule SC-200.A.3-4. on bit description.

### **Hooves and Shoes:**

No extended hooves, heavy shoes or  
toe weights allowed.

**Exception:** Collar or breast collar harness with either breaching or thimbles are required in Utility Driving.

## WESTERN ATTIRE AND TACK\*

Roping - Speed Events and Team Penning

### Personal Appointments:

Long-Sleeve Shirts with Collar (band, tuxedo,

stand-up, etc.)

, Western Hats

Western Boots

### Optional Appointments:

Spurs

Chaps or Chinks

### Prohibited Appointments:

### Tack:

Stock Saddle (*leather or synthetic*) consisting of a horn, seat, pommel, cantle, skirt, fenders, and western stirrups

Bridle - Standard Plain or Silver Headstall

with Browband Shaped or Split Ear.

Reins - Split or closed

### Optional Tack:

Hackamore, including Mechanical Hackamore

with Covered Nosepiece

Other Bridles and Bits meeting SC-270.B.1. specifications.

Tiedowns made entirely of Leather, Nylon or Rope

Running Martingales

Leg Wraps and/or Boots

Rope or Reata

### Prohibited Tack:

Jerklines

Tack Collars

Bicycle Chains and Mule Bits

### Bits:

All curb bits must be free of mechanical devices and should be considered a standard Western bit.

See bit description in Rule SC-270.B.1.

**\*EXCEPTIONS:** Calf Roping: neck rope required. "Keeper" optional. Team Roping/Steer Stopping: rope. Barrel Racing/Pole Bending: safety helmet optional.

## WESTERN ATTIRE, APPOINTMENTS AND EQUIPMENT CHART\*

Western Pleasure - Trail - Western Riding - Reining - Working Cow Horse - Cow Pony Race

### Personal Appointments:

Long-Sleeve Shirts with Collar (band, tuxedo, stand-up, etc.)  
Western Hats  
Western Boots

### Optional Appointments:

Spurs  
Chaps or Chinks  
Safety Helmets

### Tack:

Stock Saddle (*leather or synthetic*) consisting of a horn, seat, pommel, cantle, skirt, fenders, and western stirrups.  
Bridle, Standard Plain or Silver Headstall with Browband and Shaped or Split Ear  
Reins - Split or Romal

### Optional Tack:

Rope or Reata  
Mecate only with a Bosal

### Prohibited Appointments:

### Prohibited Tack:

Martingale or Tiedown  
Noseband  
Chinstrap narrower than a half-inch.  
Mechanical Hackamore

### Bits:

Whenever referring to a bit in Western performance classes, it means a curb bit that has a solid or broken mouthpiece, shanks, and acts with leverage. All curb bits must be free of mechanical devices and should be considered a standard Western bit.

See bit description in Rule SC-240-F.

Diagram of acceptable or unacceptable bits, see Rule SC-240.I.

Snaffle Bit for Junior Horses description, see Rule SC-240.E.

Diagram of chin straps, see Rule SC-240.G.

### Optional Bits/Equipment:

Hackamore for Junior Horses, see Rule SC-240.D.  
Snaffle Bit for Junior Horses, see Rule SC-240.E.

### Prohibited Bits:

Slip, Gag or Donut Bits  
Three-Piece Mouthpieces for 2-Year-Olds  
Western Pleasure  
Flat Polo Mouthpieces

**\*EXCEPTIONS:** Trail: hobbles optional for ground tie obstacle. Western Riding: leg wraps and/or boots - optional. Reining: leg wraps and/or boots - optional. Chain Curb at least a half-inch wide allowed. Working Cowhorse: leg wraps and/or boots - optional. Cow Pony Race: only two reins allowed. No racing plates. Shank bits with curb strap or curb chain must be used.

## LONGE LINE

**Personal Appointments:**  
Conventional Western

**Optional Appointments:**  
English attire, if the prospect is a Hunt Seat prospect.  
Braided Mane is acceptable.

**Tack:**  
Halter, regular or show type.  
Longe line not to exceed 30 feet in length  
with a chain or snap attached to the halter.

**Optional Tack:**  
Longe Whip  
Lead shank during the conformation judging.

-----  
**LEGEND FOR ALL RULE BOOK PATTERNS (DIAGRAMS) if applicable. See Rules SC-096, SC-255, SC-260, SC-265 and YP-125.**

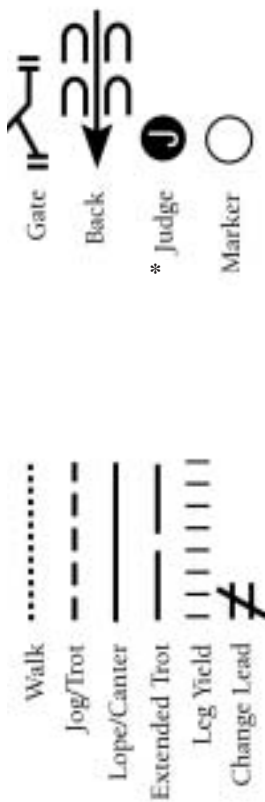

\*Judge location may be adjusted if arena conditions warrant.

## **INTERNATIONAL CLUBS**

### **AUSTRIA**

**Austrian Paint Horse Association**

### **CZECH REPUBLIC**

**Paint Horse Club Czech Republic**

### **FRANCE**

**France Paint Horse Association**

### **DENMARK**

**Paint Horse Club Denmark**

### **GERMANY**

**Paint Horse Club Germany**

### **ITALY**

**Paint Horse Club Italia**

### **LUXEMBOURG**

**Paint Horse Association Luxembourg**

### **NETHERLANDS**

**Dutch Paint Horse Club**

### **NORWAY**

**Norwegian Paint Horse Association**

### **SWEDEN**

**Swedish Paint Horse Association**

### **SWITZERLAND**

**Swiss Paint Horse Association**

### **UNITED KINGDOM**

**United Kingdom Paint Horse Association**

## **INTERNATIONAL AFFILIATES** **Foreign Registries approved by APHA**

**Paint Horse Association of Australia**  
**Associação Brasileira Do Cavallo Paint**

For contact information, call or email Regional Club Coordinator,  
Linda Foreman at 817/834-6404 or lindaf@apha.com.

# APHA Executive Committee

President

Tom Elliott  
3060 Williams Rd.  
Benson, AZ 85602  
(520) 586-3610

President-Elect

Paul Reinbolt  
10274 S. Morgantown Rd.  
Woodburn, KY 42170  
502/542-7656

Vice President

Carl Parker  
3485 W. Pioneer Rd.  
Marriott-Slaterville, UT 84404  
801/731-2331

Senior Committee Member

Richard Cox  
P.O. Box 66  
Knightstown, IN 46148  
765/345-2404

Fifth Committee Member

Alice Singleton  
88 Bristol Rd.  
Mount Vernon, AR 72111  
501/849-3127

Sixth Committee Member

Carl Thurow  
2431 S. Rd. H  
Ulysses, KS 67880  
316/356-5004

Immediate Past President

Forrest Nelson  
2496 County Rd. 8,  
Meeker, CO 81641  
(970) 878-4721

Executive Secretary

Jim Kelley  
P.O. Box 961023  
Fort Worth, Texas 76161  
817/834-2742

## APHA Department Extensions

Office hours are Monday through Friday, 8:00 a.m to 4:30 p.m.

P.O. Box 961023, Fort Worth, Texas 76161-0023

Physical Address and Phone Number

2800 Meacham Blvd., Fort Worth, Texas 76137-4603

(817) 834-APHA (2742)

**Administration** - Responsible for management of APHA, Coordinates the activities of the Executive Committee, Board of Directors, Workshop and Convention.

Executive Secretary	Jim Kelley	ext. 403
Administrative Assistant	Theresa Anderson	403
Regional Club/National Director Coordinator	Linda Foreman	404
Facilities Manager/APHHF Coordinator	Audrey Choate	410

**Accounting Department** - Responsible for financial management of the association. Payables, receivables, employee benefits. Journal billing and subscriptions.

Controller/Business Manager	Steve Wasson	409
Department Head	Aleta Wood	421
Director of Accounting/YDF Coordinator	Rosemary Teate	422
Journal Billing	Gail Comer	817/222-8454
Accounts Receivable (Memberships and Subscriptions)	Group Number	772

**Data Processing** - Responsible for electronic management of all data, programming and computer support.

Manager	Bob Steach	405
---------	------------	-----

### Field Services -

Division Manager	Cindy Grier	413
Director of Field Services	Barbara Scheffler	235
Genetic Testing		308
Investigations		235
Ranch and individual inspections, drug testing		817/222-8456
Transported semen		221
Embryo transfer		221

**General Store** - APHA Items for Sale . . . . .1-877-460-6275

Literature and Forms Request . . . . .261

**Marketing Department** - Responsible for APHA promotion, services and communication.

Director of Communications (Newsletters and Press Releases)	Jerry Circelli	438
Director of Marketing & Promotions (Advertising and Corporate Sponsorships)	Gina Phipps	433
Director of Youth Activities	Ruthie Stotler	248
Marketing Assistant		328

**Member Services** - Responsible for member benefits, legal questions, international members and rule book.

Department Head	Jan Anderson	414
	Group Number	776

**Paint Horse Journal** - Responsible for magazine publishing and advertising sales.

Journal/Circulation .....	Mary Reales	817/222-6431
Advertising .....		
..... Western Region ..		817/222-6432
..... Central Region ..		817/222-6430
..... Eastern Region ..		817/222-6429
..... Classified Ads ..		817/222-6417

**Performance Department** - Responsible for show rules, approval and results; performance points; performance awards; Amateur/Novice Amateur and Youth programs; Paint Alternative Competition (PAC); Ride America.

..... Group Number ..		817/222-8455
Division Manager .....	Lex Smurthwaite	412
Director of Shows .....	Tina Anderson	436
Director of Judges/Breeders Trust .....	Candy Cain	416
Director of Amateur Activities .....	Jasmine Jones	447
Racing Coordinator .....	Karen Utecht	444
Director of Recreational Riding/ .....		
Trail Rides .....	Cody Weirich	439

**Registration Department** - Responsible for registration and transfers, including stallion breeding reports, registration applications and certificates, pedigrees and rules.

Division Manager .....	Cindy Grier	413
Department Head/Registrar .....	Allyson Pennington	247
General Information .....		817/222-8451
Team Numbers		
International .....	Team 1 - 817/222-6423 .. Team 2 - 817/222-6424	
Rush Work .....	Team 3 - 817/222-6425 .. Team 4 - 817/222-6426	
.....	Team 5 - 817/222-6427 .. Team 6 - 817/222-6428	

To give you faster service, dial directly to a team by calling these telephone numbers.

# MAP TO APHA OFFICES

2800 Meacham Blvd.  
Fort Worth, Texas 76137

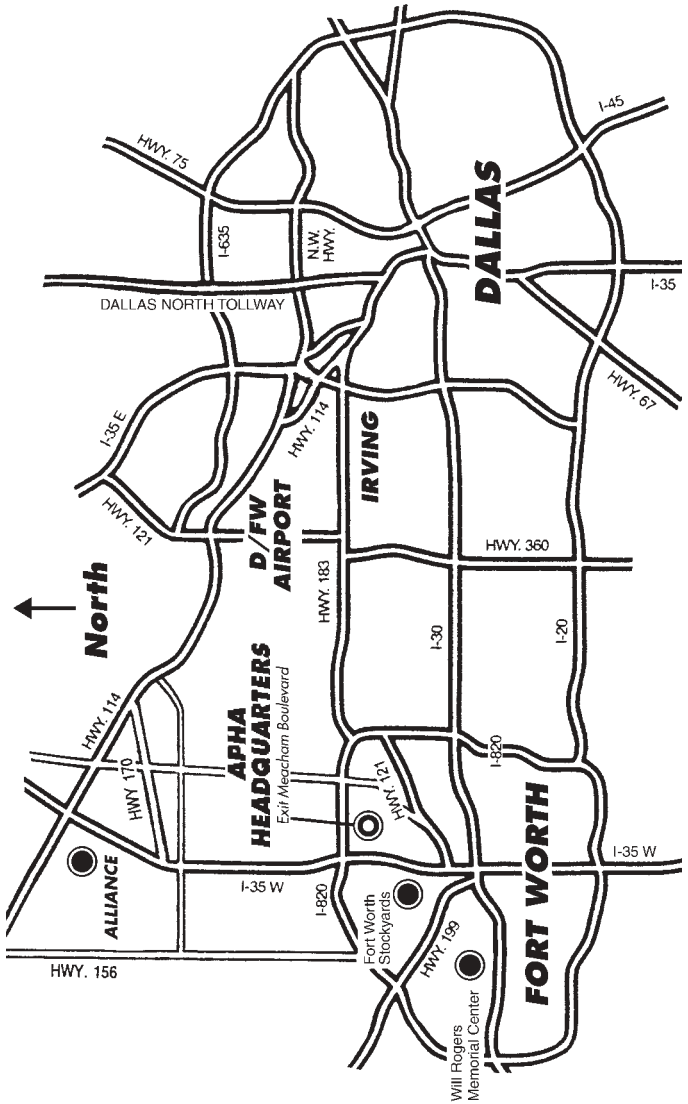

**American Paint Horse Association  
Membership Application**

(Please print clearly and provide complete information.)

Name \_\_\_\_\_

(Cannot exceed thirty (30) characters and spaces.)

ID No. (if known) \_\_\_\_\_

Street \_\_\_\_\_

City \_\_\_\_\_

State/Province \_\_\_\_\_

Zip/Postal Code \_\_\_\_\_

Country \_\_\_\_\_

Membership Level: Youth DOB \_\_\_\_/\_\_\_\_/\_\_\_\_

\_\_\_\_ Junior (\$12.50/year must be 18 years of age or under)

\_\_\_\_ J-Term (\$100 one time junior membership through  
age 18)

\_\_\_\_ Regular (\$25/year) \_\_\_\_ 3-Year (\$65) \_\_\_\_ 5-Year (\$100)

\_\_\_\_ Lifetime (\$300)

**Paint Horse Journal Subscription**

\_\_\_\_ Single Copy \$4.50\*

\_\_\_\_ 1 Year-Member Rate, U.S., \$30

\_\_\_\_ 1 Year-Non-Member Rate, U.S., \$35

\_\_\_\_ 3 Year-Member Rate, U.S. \$75

\_\_\_\_ 3 Year-Non-Member Rate, U.S. \$90

\_\_\_\_ 1 Year-Member Rate, Canadian, \$45

\_\_\_\_ 1 Year-Non-Member Rate, Canadian \$50

\_\_\_\_ 3 Year-Member Rate, Canadian, \$120

\_\_\_\_ 3 Year-Non-Member Rate, Canadian \$135

\_\_\_\_ 1 Year-Member Rate, International, \$75

\_\_\_\_ 1 Year-Non-Member Rate, International, \$80

\*Add \$2 shipping & handling in U.S., outside U.S. add \$5.

Membership Dues \$ \_\_\_\_\_

Journal Subscription \$ \_\_\_\_\_

Total \$ \_\_\_\_\_

**Method of Payment**

\_\_\_\_ Check or Money Order Enclosed

\_\_\_\_ Please Charge to my credit card:

Type of Card: \_\_\_\_ Master Card \_\_\_\_ Visa

Card No. \_\_\_\_\_

Expiration Date: \_\_\_\_\_

Name on Card: \_\_\_\_\_

Signature \_\_\_\_\_

**Return to: American Paint Horse Association  
P. O. Box 961023  
Fort Worth, Texas 76161-0023  
817/834-APHA (2742); Fax (817) 834-3152**